

Colle cti on

Collection 2024

Collection 2024

zanotta:

zanotta:

Collection

2024

zanotta:

Index

12-63

Divani
Sofas
Canapés
Sofas
Sofás

64-85

Poltrone
Armchairs
Fauteuils
Sessel
Butacas

86-113

Tavolini, Comodini
Small Tables, Nightstands
Petites tables, Tables de chevet
Couchtische, Nachttische
Mesitas, Mesitas de noche

114-135

Sedie
Chairs
Chaises
Stühle
Sillas

136-169

Tavoli, consolle, scrivanie
Tables, console tables, desks
Tables, consoles, tables bureau
Tische, Wandtische,
Schreibtische
Mesas, consolas,
mesas escritorios

170-189

Letti
Beds
Lits
Betten
Camas

190-215

Complementi d'arredo
Furnishing accessories
Compléments d'ameublement
Wohnaccessoires
Complementos de decoracion

216-221

Contentitori
Sideboards
Container
Sideboard
Muebles contenedores

222-227

Specchi
Mirrors
Miroirs
Spiegel
Espejos

Products

A

Albero 192
Alfa 14
Allunaggio 193
Ambrosiano 138
April 116
Ara Fenice 194 **NEW**
Arabesco CM 88
Ardea CM 66
Arom 67
Aster 195

B

Basello 89
Bol 140
Bol 142 **NEW**
Box 172
Bruce 18
Bumper 22
Butterfly 90

C

Calamo 145
Calla 68
Campiello+ 69
Carlino CM 91
Cavour CM 146
Celestina 117
Chichibio 196
Club 26
Comacina 148
Confortevole 188
Cuculia 197 **NEW**
Cumano 92

D

Daisy 119
Dan Outdoor 118
Dealbata 198 **NEW**
Derby 70

E

Echino 93
Fenice 150
Fenis CM 122
Flamingo 28
Follia 199
Formaplus 188

G

Galeotta 71
Genni 72
Gilda CM 73
Giotto 200
Girò 94
Giuno 120 **NEW**
Gomma 74 **NEW**
Grangala 174
Graphium 95

I

Ido 123

J

Joy 201

K

Karelia 75
Kent 76-77
Kilt / Kilt 84 32

L

Lama 78
Lazy Susan 144 **NEW**
Lea 124
Lealta 125
Leonardo 151
Lia 126
Lialta 127
Lio/Leo 128
Lord 129

M

Maggiolina 79
Marcuso 152
Mezzadro 202
Milano 176
Milano+ 36
Milo CM 224
Mollaplust 188
Molleggio 188
Moretta 80
Museo 203

N

Natura 188
Nena 130
Nena Lounge 81
Nena Stool 131
Niobe 96

Noah 38
Nyx 178

O

Oliva 82
Onda 42
Orione 153
Oscar 97

P

Parco 43
Pianoalto
/ Pianoalto 96 44
Pisolo 189
Poker 154
Primate 204

Q

Quaderna Carpet 205
Quaderna
Coffee Table 98
Quaderna Consolle 158
Quaderna Cupboard 218
Quaderna Desk 156
Quaderna Mirror 225
Quaderna Sideboard 219
Quaderna Small
Table 99
Quaderna Table 155
Quaderna
Writing Desk 157

R

Raperonzolo 226
Reale 159
Reale CM 160
Ricordi 180

S

Sacco 83
Sacco Medium 83
Sacco Small 83
Sant'Elia 84
Sciangai 206
Sciangai 50 207
Sella 208
Servento 209
Servietto 210
Servobandiera 211
Servofumo 212
Servomanto 213
Servomuto 100
Servonotte 210
Servopluvio 212
Servostop 214
Sgabillo 101
Shiki 48
Sosia 227 **NEW**
Susanna 85

T

Ta.Ba.Ce. 102 **NEW**
Talamo 182
Talia 132
Taschino 103

Talamo Box 184 **NEW**
Tempo 104
Teti 105
Thar 215
Throw-Away 52
Tidone 162 **NEW**
Tod 106
Toi 107
Toniotta 133
Topper 188
Toto 108
Tucano 164
Tusa High 134
Tusa Low 135
Tweed 165-166 **NEW**
Tweed Marble 167
Tweed Mini 109

W

William 54

Z

Zavolo Coffee
Table 112 **NEW**
Zavolo Consolle 168 **NEW**
Za:Za 62
Za:Za Bed 186 **NEW**
Za:Za Max 60 **NEW**
Zeus 113
Z24 Nightstand 111 **NEW**
Z24 Cupboard 220 **NEW**
Z24 Sideboard 221 **NEW**

Living

SOFAS

Alfa 14
Bruce 18
Bumper 22
Flamingo 28
Kilt – Kilt 84 32
Milano+ 36
Noah 38
Onda 42
Pianoalto
/Pianoalto 96 44
Shiki 48
Throw-Away 52
William 54
Za:Za 62
Za:Za Max 60

ARMCHARIS

Ardea CM 88
Arom 67
Calla 68
Campiello+ 69
Derby 70
Galeotta 71
Genni 72
Gilda CM 73
Gomma 74
Karelia 75
Kent 76-77
Lama 78

Maggiolina 79
Nena Lounge 81
Oliva 82
Sacco 83
Sant'Elia 84
Susanna 85

SMALL TABLES

Arabesco CM 88
Basello 89
Butterfly 90
Carlino CM 91
Cumano 92
Echino 93
Girò 94
Graphium 95
Niobe 96
Quaderna Coffee Table 98
Quaderna Small Table 99
Servomuto 100
Sgabillo 101
Ta.Ba.Ce. 102
Tempo 104
Teti 105
Tod 106
Toi 107
Toto 108
Tweed Mini 109
Zavolo Coffee
Table 112
Zeus 113

FURNISHING ACCESSORIES

Albero 192
Allunaggio 193
Ara Fenice 194
Aster 195
Chichibio 196
Cuculia 197
Dealbata 198
Follia 199
Giotto 200
Joy 201
Mezzadro 202
Museo 203
Primate 204
Quaderna Carpet 205
Sciangai 206
Sciangai50 207
Sella 208
Servomanto 213
Thar 215

MIRRORS

Milo CM 224
Quaderna Mirror 225
Raperonzolo 226
Sosia 227

SIDEBOARDS

Quaderna Cupboard 218
Quaderna Sideboard 219
Z24 Cupboard 220
Z24 Sideboard 221

Dining

CHAIRS/ARMCHAIRS

April 116
Arom 67
Calla 68
Celestina 117
Daisy 119
Fenis CM 122
Giuno 120
Ido 123
Lea/Lia 124-126
Lealta/Lialta 125-127
Lio/Leo 128
Nena 130
Nena Stool 131
Talia 132
Tonietta 133
Tusa 134-135

TABLES

Ambrosiano 138
Bol 140-142
Fenice CM 122
Marcuso 152
Orione 153
Quaderna Table 155
Reale 159
Reale CM 160
Tidone 162
Tweed 165-166
Tweed Marble 167

MIRRORS

Milo CM 224
Quaderna Mirror 225
Raperonzolo 226
Sosia 227

FURNISHING ACCESSORIES

Albero 192
Ara Fenice 194
Carlino CM 91
Chichibio 196
Cuculia 197
Dealbata 198
Joy 201
Mezzadro 202
Thar 215
Zavolo Consolle 168

SIDEBOARDS

Quaderna Cupboard 218
Quaderna Sideboard 219
Z24 Cupboard 220
Z24 Sideboard 221

Outdoor

SOFAS

Club 26
Parco 43

CHAIRS

April 116
Dan Outdoor 118
Sacco 83

SMALL TABLES

Ta.Ba.Ce. 102
Teti 105
Zeus 113

FURNISHING ACCESSORIES

Allunaggio 193
Servofumo 212
Servopluvio 212
Servobandiera 211

Designers

Sleeping

BEDS

Box 172
Grangala 174
Milano 176
Nyx 178
Ricordi 180
Talamo 182
Talamo Box 184
Za:Za Bed 186

NIGHTSTAND/SMALL TABLES

Basello 89
Carlino CM 91
Cumano 92
Oscar 97
Servomuto 100
Sgabillo 101
Taschino 103
Tempo 104
Tod 106
Toi 107
Z24 Nightstand 111

FURNISHING ACCESSORIES

Aster 195
Museo 203
Sciangai50 207
Sciangai 206
Servomanto 213
Servonotte 210
Servietto 210

MIRRORS

Milo CM 224
Quaderna Mirror 225
Raperonzolo 226
Sosia 227

Home Office

DESKS

Comacina 148
Cavour CM 146
Calamo 145
Tucano 164
Quaderna Desk 156

Quaderna Writing
Desk 157

CHAIRS/ARMCHAIRS

Calla 68
Daisy 119
Giuno 120
Lord 129
Nena 130
Tusa 134-135

A

Atelier Oi
Gae Aulenti

B

Roberto Barbieri
Liisi Beckmann
Max Bill
Piero Bottoni
Todd Bracher

C

Calvi Brambilla
Federica Capitani
Achille e Pier Giacomo
Castiglioni
Achille Castiglioni
Joe Colombo

D

De Pas - D'Urbino -
Lomazzi
Anna Deplano
Rodolfo Dordoni
Alessandro Dubini
Noé Duchaufour
Lawrance

E

Emaf Progetti

F

Monica Förster

G

Garcia Cumini
Gatti - Paolini -
Teodoro
Guisset Constance

H

Alfredo Häberli
Sebastian Herkner

I

Salvatore Indriolo

L

Ugo La Pietra
Willie Landels
Lanzavecchia + Wai
Bertrand Lejoly
Gino Levi Montalcini

M

Philippe Malouin
Enzo Mari
Bernard Marstaller
Mist-o
Carlo Mollino
Gabriele Mucchi
Muller Van Severen

N

Patrick Norguet

P

Giuseppe Pagano
Pogatschnig
Ludovica+Roberto
Palomba

R

Prospero Rasulo
Frank Rettenbacher
Gabriele Rosa

S

Spalvieri & Del Ciotto
Superstudio

T

Alexander Taylor
Giuseppe Terragni

W

Damian Williamson

Z

Marco Zanuso
Zaven

Divani
Sofas
Canapés
Sofas
Sofás



Design

Emaf Progetti

1999

Poltrona, divani monoblocco, componibili, pouf

Piedini in acciaio cromato, o nichel satinato colore naturale o nero, oppure verniciato colore grafite. Struttura in acciaio. Molleggio su nastri elastici. Imbottitura in poliuretano/ fibra poliestere termolegata. Rivestimento sfilabile in stoffa o in pelle, con cuscino seduta trapuntato. Cuscinetti in Dacron Du Pont o piumón d'oca.

Armchair, monobloc, modular sofas, poufs

Steel feet, chromium-plated or varnished graphite, or with natural or black nickel-satin finish. Steel frame. Elastic strips suspension. Upholstery in polyurethane/ heat-bound polyester fibre. Fabric or leather removable cover with quilted seat cushion. Small cushions in Dacron Du Pont or in goose down.

Fauteuil, canapés monoblocs, composables, poufs

Pieds en acier chrome ou nickel satiné, dans les couleurs naturel ou noir, ou verni couleur graphite. Structure en acier. Suspension sur sangles élastiques. Rembourrage en polyuréthane/fibre polyester liée à chaud. Revêtement avec coussin assise surpiqué, déhoussable en tissu ou en cuir. Coussinets en Dacron Du Pont ou en duvet d'oie.

Sessel, einteilige – zusammenstellbare Sofas, Hocker

Füße aus Stahl, verchromt oder mit naturfarben- oder schwarz- vernickeltem und mattiertem Finish oder Graphit lackiert. Gestell aus Stahl. Federung mit elastischen Gurten. Polsterung aus Polyurethan/ wärmegebundener Polyesterfaser. Abnehmbarer Bezug mit Steppung über den Sitzpolstern aus Stoff oder Leder. Kleine Kissen aus Dacron Du Pont oder aus Gänsedaunen.

Butaca, sofás monobloque, modulares, púfs

Pies de acero cromado, o niquelado mate en los acabados natural o negro o pintado color grafito. Estructura de acero. Suspensión sobre cintas elásticas. Acolchado de poliuretano/fibra poliéster termounida. Tapizado desenfundable de tejido o de piel, con cojín del asiento respuntado. Cojines de Dacron Du Pont o de plumón de ganso.

Piedini/Feet/Pieds/Füße/Patas

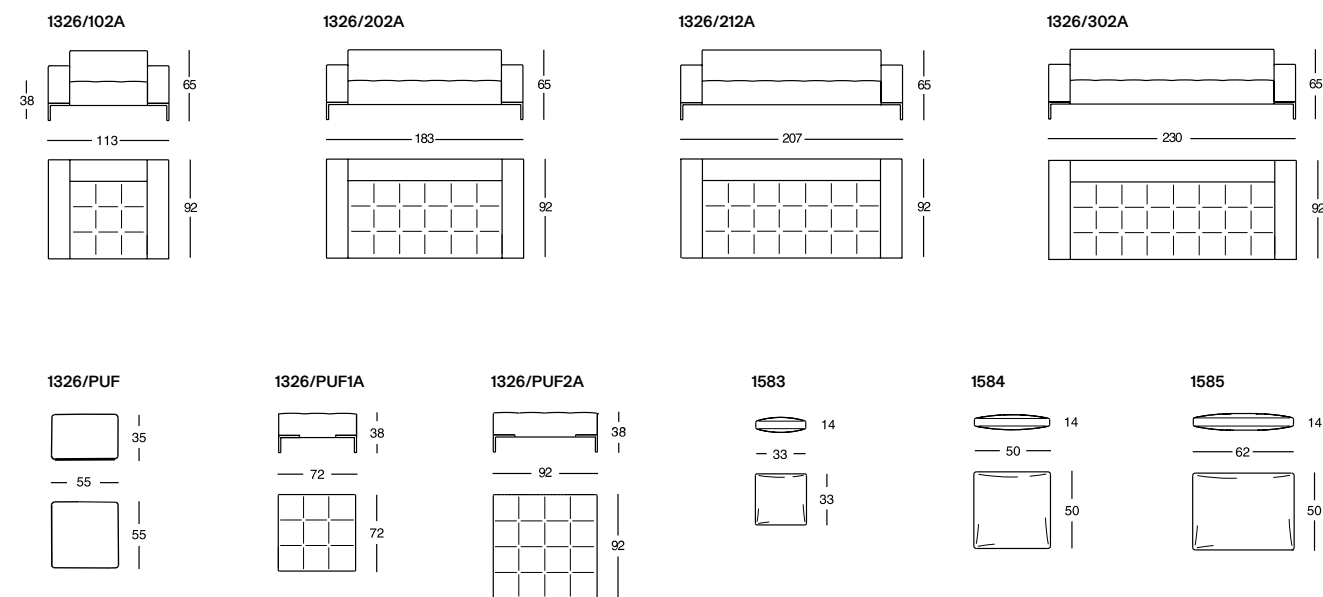

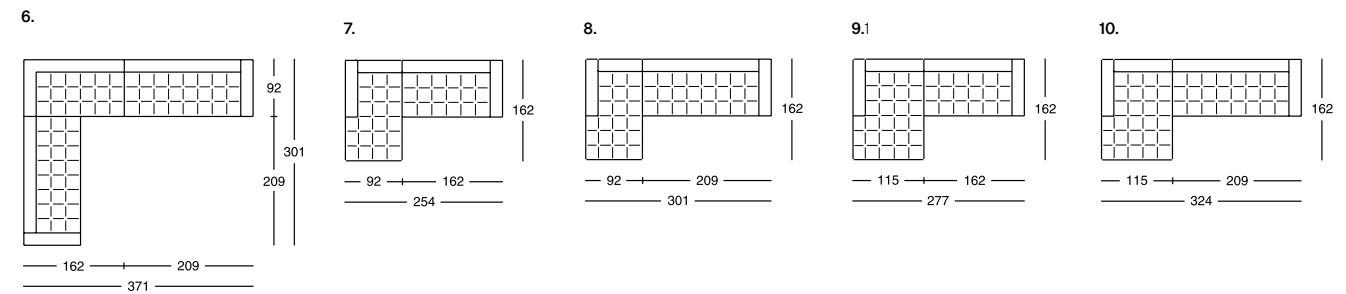
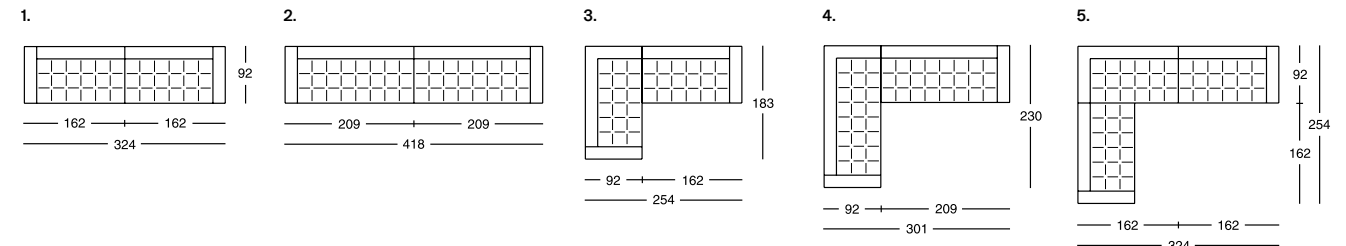
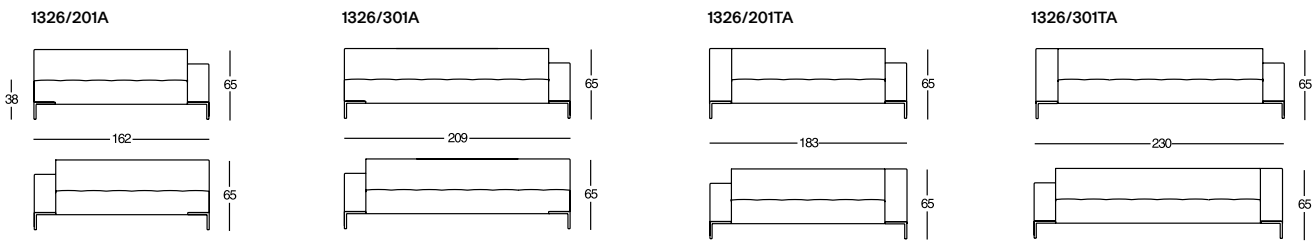
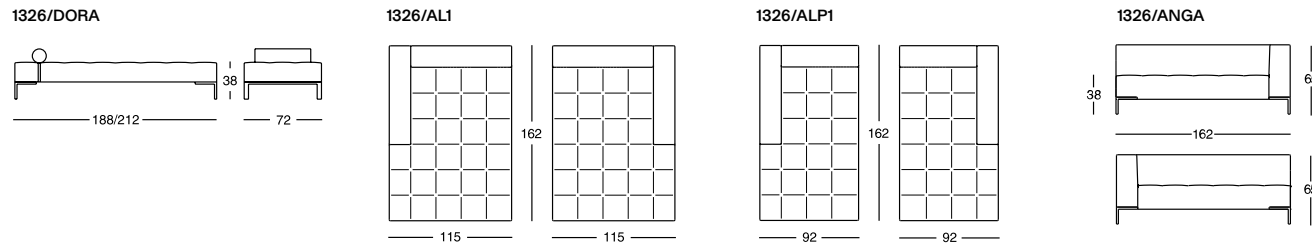
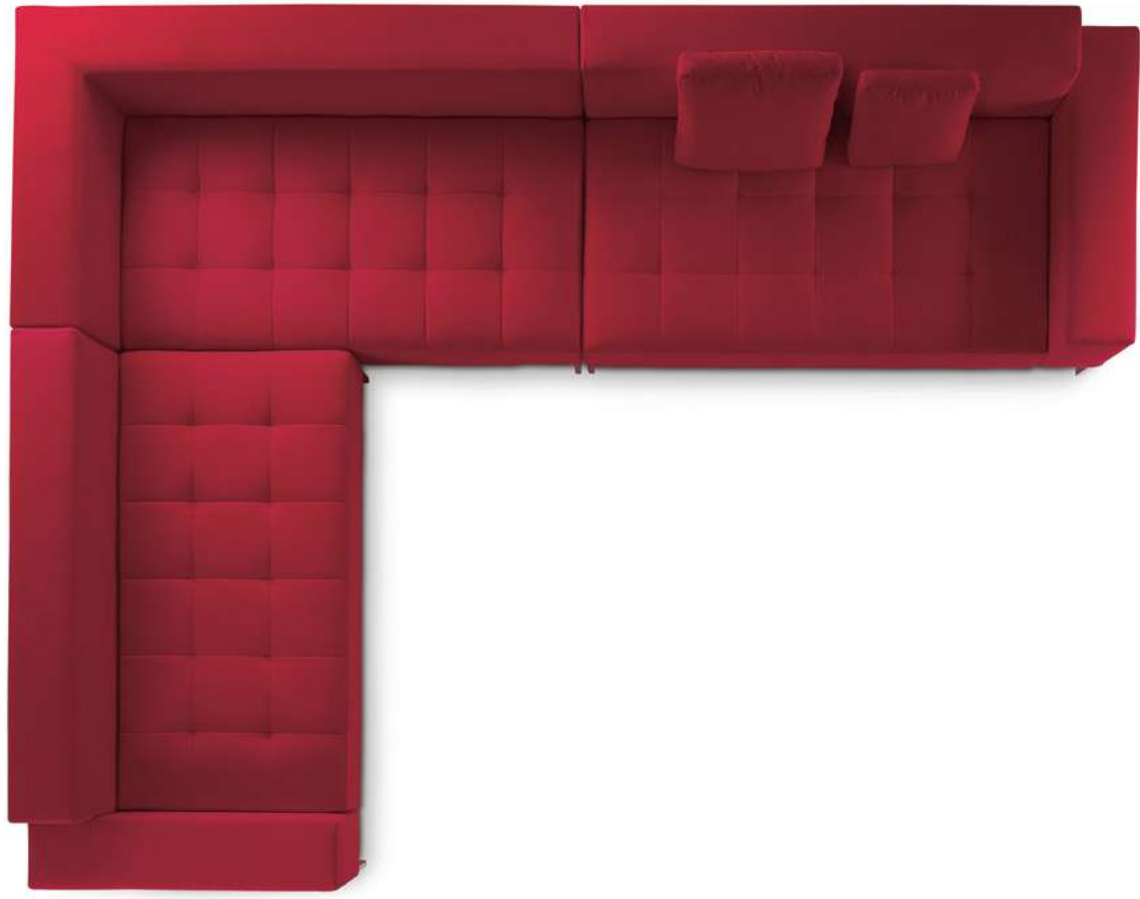



Design

Ludovica+Roberto Palomba

2013

Divani monoblocco, componibili, pouf
Piedini in lega di alluminio lucidato, nichelsatinato colore naturale o nero, oppure verniciato colore nero. Struttura in acciaio. Molleggio su nastri elastici. Imbottitura in poliuretano/ Dacron Du Pont. Cuscino seduta in poliuretano/

Dacron Du Pont. Cuscini schienale e bracciolo in piuma d'oca. Imbottitura rullo in poliuretano/fibra poliestere termolegata. Rivestimento sfilabile in stoffa o pelle.

Monobloc and modular sofas, pouf
Polished aluminum alloy, or with natural or black nickel-satin finish, or black painted. Steel frame. Elastic strips suspension. Upholstery in polyurethane/Dacron Du Pont. Seat cushion in polyurethane/Dacron Du Pont. Back and armrest

cushions in goose feather. Upholstery of roll-shaped cushion in polyurethane/heat-bound polyester fibre. Removable cover in fabric or leather.

Canapés monoblocs, composables, pouf
Pieds en alliage d'aluminium poli ou nickel satiné, dans les couleurs naturel ou noir, ou verni noir. Structure en acier. Suspension sur sangles élastiques. Rembourrage en polyuréthane/Dacron Du Pont. Coussin du siège en polyuréthane/ Dacron Du

Pont. Coussins du dossier et accoudoir en plumes d'oie. Rembourrage de cale-reins en polyuréthane/fibre polyester liée à chaud. Revêtement déhoussable en tissu ou en cuir.

Einteilige, zusammenstellbare Sofas, Hocker
Füße aus Aluminiumlegierung, poliert oder mit naturfarben oder schwarz- vernickeltem und mattiertem Finish, oder schwarz lackiert. Stahlgestell. Federung auf elastischen Gurten. Polsterung aus

Polyurethan/Dacron Du Pont. Sitzkissen aus Polyurethan/ Dacron Du Pont. Rücken und Armlehne-Kissen aus Gänsefedern. Polsterung der Nierenrolle aus Polyurethan/ wärmegebundener Polyesterfaser. Abnehmbarer Bezug aus Stoff oder Leder.

Sofás monobloques, modulares, pouf
Patas de aleación de aluminio pulido o niquelado mate en los acabados natural o negro, o pintado negro. Estructura de acero. Suspensión sobre cintas elásticas. Acolchado de poliuretano/Dacron

Du Pont. Cojín asiento de poliuretano/Dacron Du Pont. Cojines de respaldo y apoyabrazo de pluma de ganso. Acolchado de cojín lumbar de poliuretano/ fibra poliéster termounida. Tapizado desenfundable de tejido o piel.

Piedini/Feet/Pieds/Füße/Patas

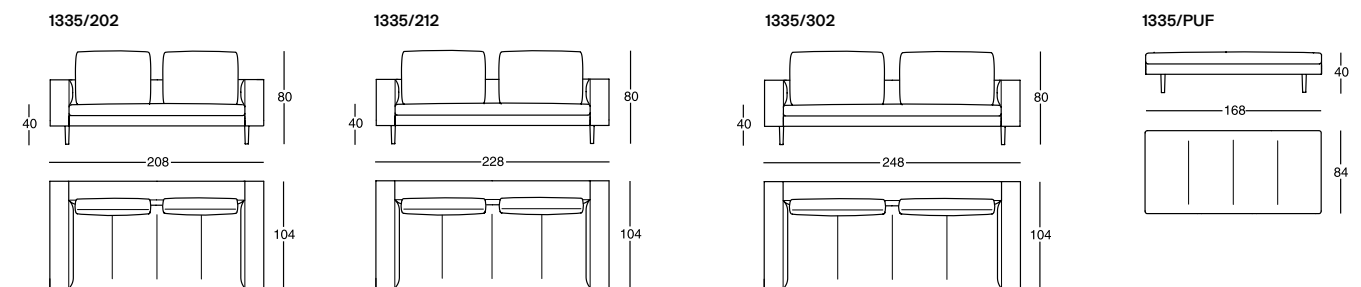

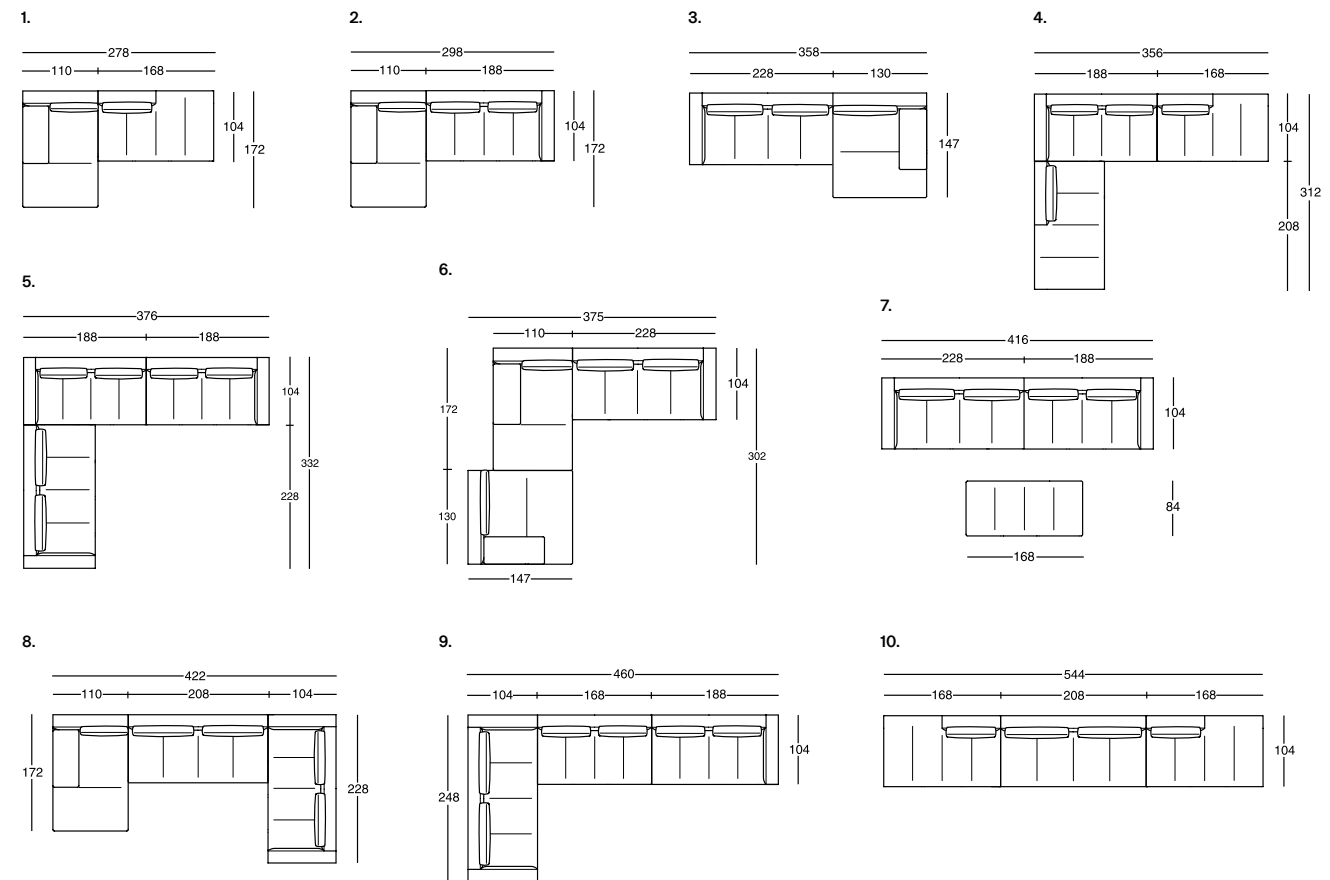
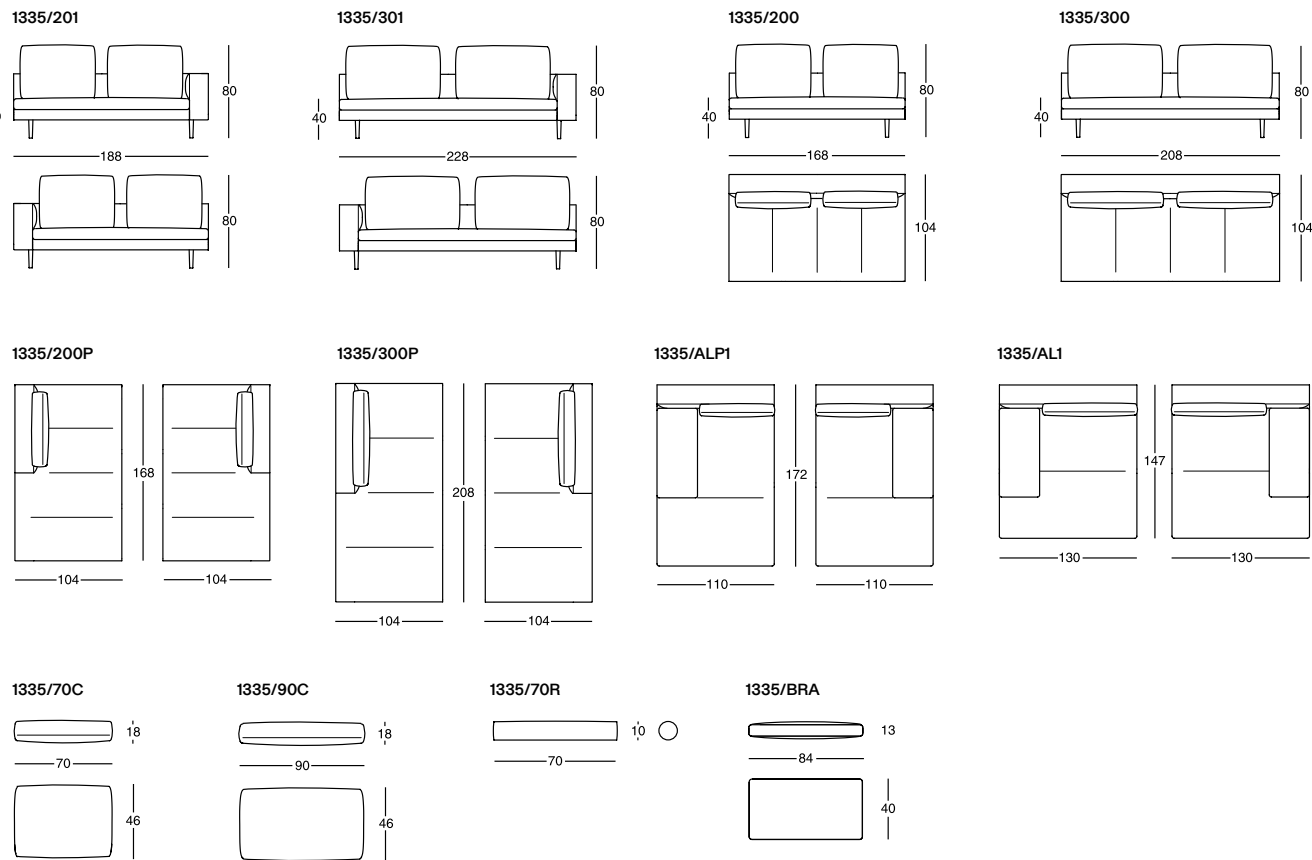



Design

Calvi Brambilla

2023

Divani monoblocco e componibili, pouf e cuscino

Struttura in legno. Molleggio su nastri elastici. Imbottitura sedile, schienale e base in poliuretano a quote differenziate/ Dacron Du Pont. Cuscino in fiocchi di poliestere rigenerato e rigenerabile. Rivestimento sfilabile in stoffa.

Monobloc and modular sofas, pouf and cushion

Wooden frame. Elastic strips suspension. Seat, back and base upholstered in graduated polyurethane/ Dacron Du Pont. Cushion in regenerated and regenerable polyester flakes. Removable fabric cover.

Canapés monoblocs et composables, pouf et coussin

Structure en bois. Suspension sur sangles élastiques. Rembourrage assise, dossier et base en polyuréthane à densité variable/ Dacron Du Pont. Coussin en flocons de polyester régénérés et régénérables. Revêtement déhoussable en tissu.

Einteilige und zusammenstellbare Sofas, Hocker und Kissen

Gestell aus Holz. Federung auf elastischen Gurten. Sitz-, Rücken- und Basispolsterung aus Polyurethan mit unterschiedlicher Dichte/ Dacron Du Pont. Kissen aus regenerierten und regenerierbaren Polyesterflocken. Abnehmbarer Bezug aus Stoff.

Sofás monobloque y modulares, puf y cojín

Estructura de madera. Suspensión sobre cintas elásticas. Asiento, respaldo y base de poliuretano a densidades diferenciadas/ Dacron Du Pont. Cojín de copos de poliéster regenerado y regenerable. Tapizado desenfundable de tejido.

1265/212

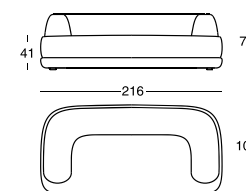

1265/302

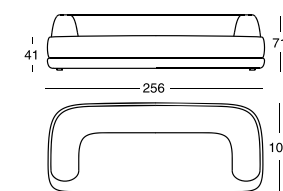

1265/300P

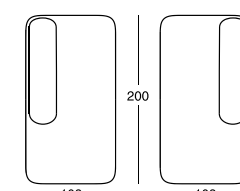

1265/AL1

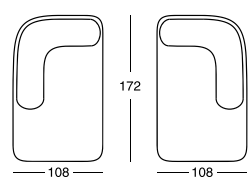

1265/201

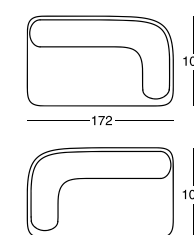

1265/ANG1

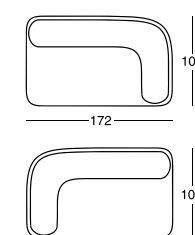

1265/PUF

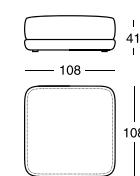

1265/50C

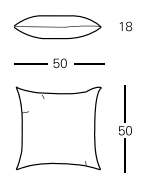

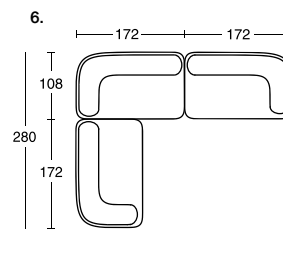
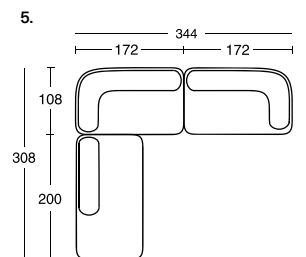
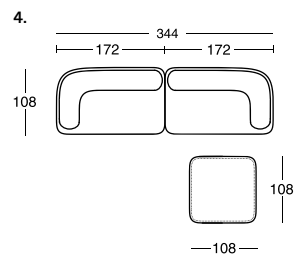
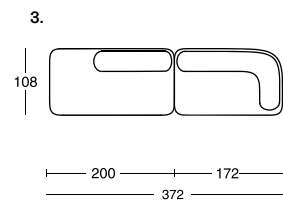
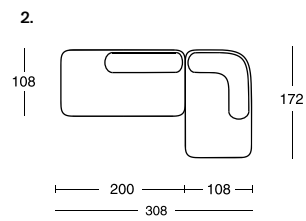
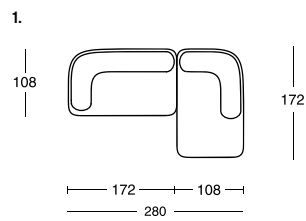

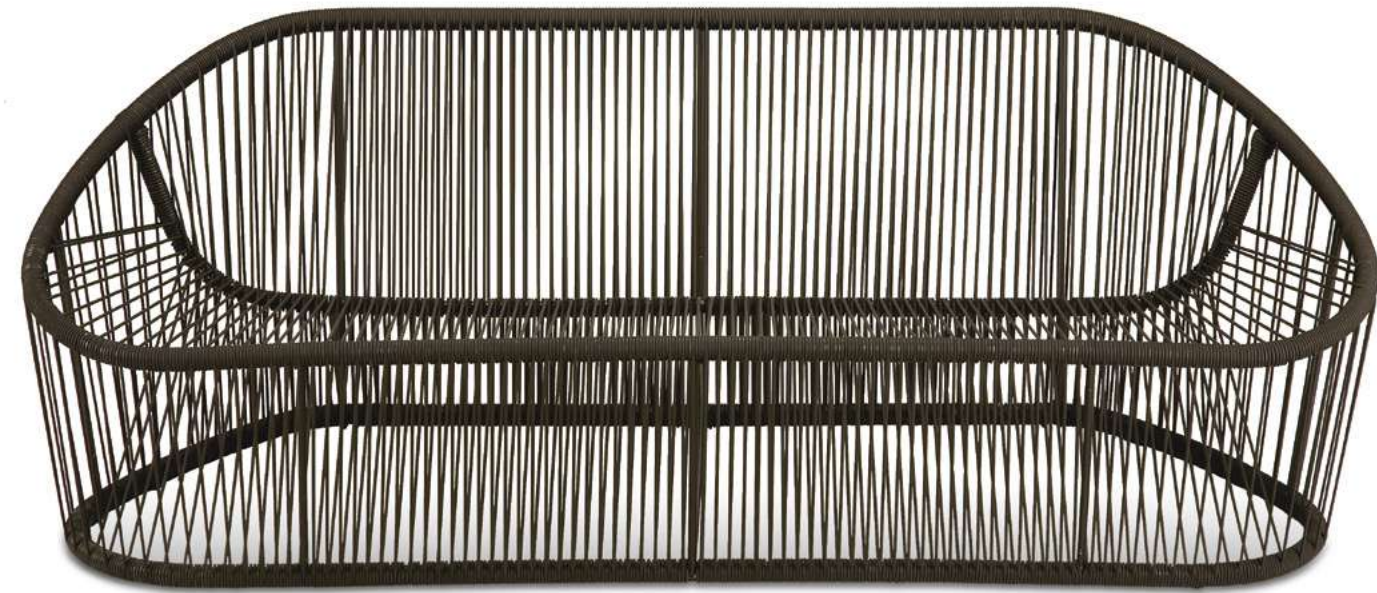

Design

Prospero Rasulo

2008

IN/OUT

Poltrona e divano per esterni e interni

Struttura interna in acciaio verniciato per esterni. Incordatura in filo di PVC con rinforzo interno di nylon colore marrone. A richiesta

è disponibile un cuscinetto di seduta imbottito in poliuretano/Dacron Du Pont.

Armchair and sofa for outdoor and indoor

Steel internal structure painted for outdoor use. Weave in brown PVC thread with nylon internal reinforcement. Upon

request a small seat cushion upholstered with polyurethane/Dacron Du Pont is available.

Fauteuil et canapé pour extérieurs et intérieurs

Structure interne en acier verni pour extérieurs. Tressage en fil de PVC avec renfort interne en nylon, couleur marron. Sur

demande est disponible un coussinet du siège rembourré en polyuréthane/Dacron Du Pont.

Sessel und Sofa für Innen und Freie

Innere Struktur aus lackiertem Stahl fürs Freie. Geflecht aus PVC Draht mit innerer Verstärkung aus Nylon in der Farbe

braun. Auf Nachfrage ist ein gepolstertes Sitzkissen mit Polyurethan/Dacron Du Pont verfügbar.

Sillón y sofá para exteriores y interiores

Estructura interior de acero pintado para exteriores. Trenzado en hilo de PVC con refuerzo interno de nylon color marrón. Sobre

pedido es disponible un cojín pequeño de asiento acolchado de poliuretano/Dacron Du Pont.

1009/102

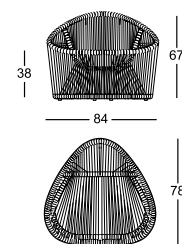

1009/302

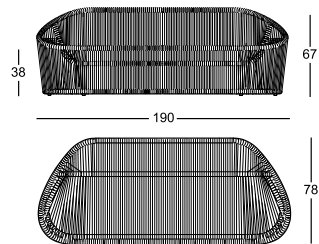



Design

Damian Williamson

2017

Poltrona, divani monoblocco e componibili

Piedini in lega di alluminio lucidato, nichelsatinato colore naturale o nero, oppure verniciato colore nero. Struttura in acciaio. Molleggio su nastri elastici. Imbottitura in poliuretano/fibra poliestere termolegata. Cuscino seduta in poliuretano/fibra poliestere termolegata. Imbottitura cuscini schienale e poggiatesta in piuma d'oca. Rivestimento sfilabile in stoffa o in pelle.

Armchair, monobloc and modular sofas.

Polished or black painted aluminum alloy feet, or with natural or black nickel-satin finish. Steel frame. Elastic strips suspension. Upholstery in polyurethane/heat-bound polyester fibre. Seat cushion upholstered with polyurethane/heat-bound polyester fibre. Back and lumbar cushions upholstered with goose feathers. Removable fabric or leather cover.

Fauteuil et canapés monoblocs et composables

Pieds en alliage d'aluminium poli, ou nickel satiné, dans les couleurs naturel ou noir, ou vernis noir. Structure en acier. Suspension sur sangles élastiques. Rembourrage en polyuréthane/fibre polyester liée à chaud. Coussins d'assise en polyuréthane/fibre polyester liée à chaud. Rembourrage en plume d'oie. Revêtement déhoussable en tissu ou en cuir.

Sessel, einteilige und zusammenstellbare Sofas

Füße aus polierter oder schwarz-lackierter Aluminiumlegierung, oder mit naturfarben- oder schwarz vernickeltem und mattiertem Finish. Gestell aus Stahl. Federung auf elastischen Gurten. Polsterung aus Polyurethan/wärmegebundener Polyesterfaser. Sitzkissen aus Polyurethan/wärmegebundener Polyesterfaser. Polsterung der Rücken- und Nierenkissen aus Gänsfedern. Abnehmbarer Bezug aus Stoff oder Leder.

Butaca, sofás monobloque y modulares

Patas de aleación de aluminio pulido, o niquelado mate en los acabados natural o negro, o pintado negro. Estructura de acero. Suspensión sobre cintas elásticas. Acolchado de poliuretano/fibra poliéster termounida. Cojín asiento de poliuretano/fibra poliéster termounida. Cojín de respaldo y lumbar acolchados con pluma de ganso. Tapizado desenfundable de tejido o de piel.

Piedini/Feet/Pieds/Füße/Patas

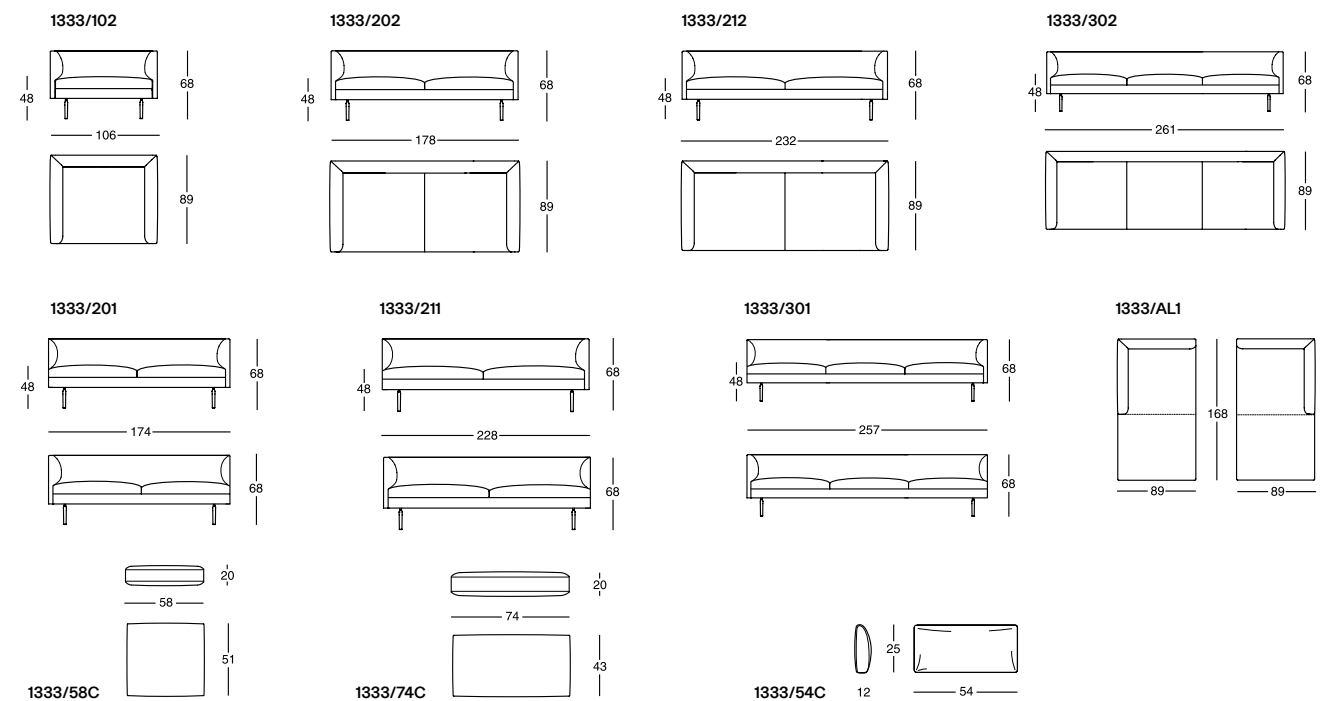

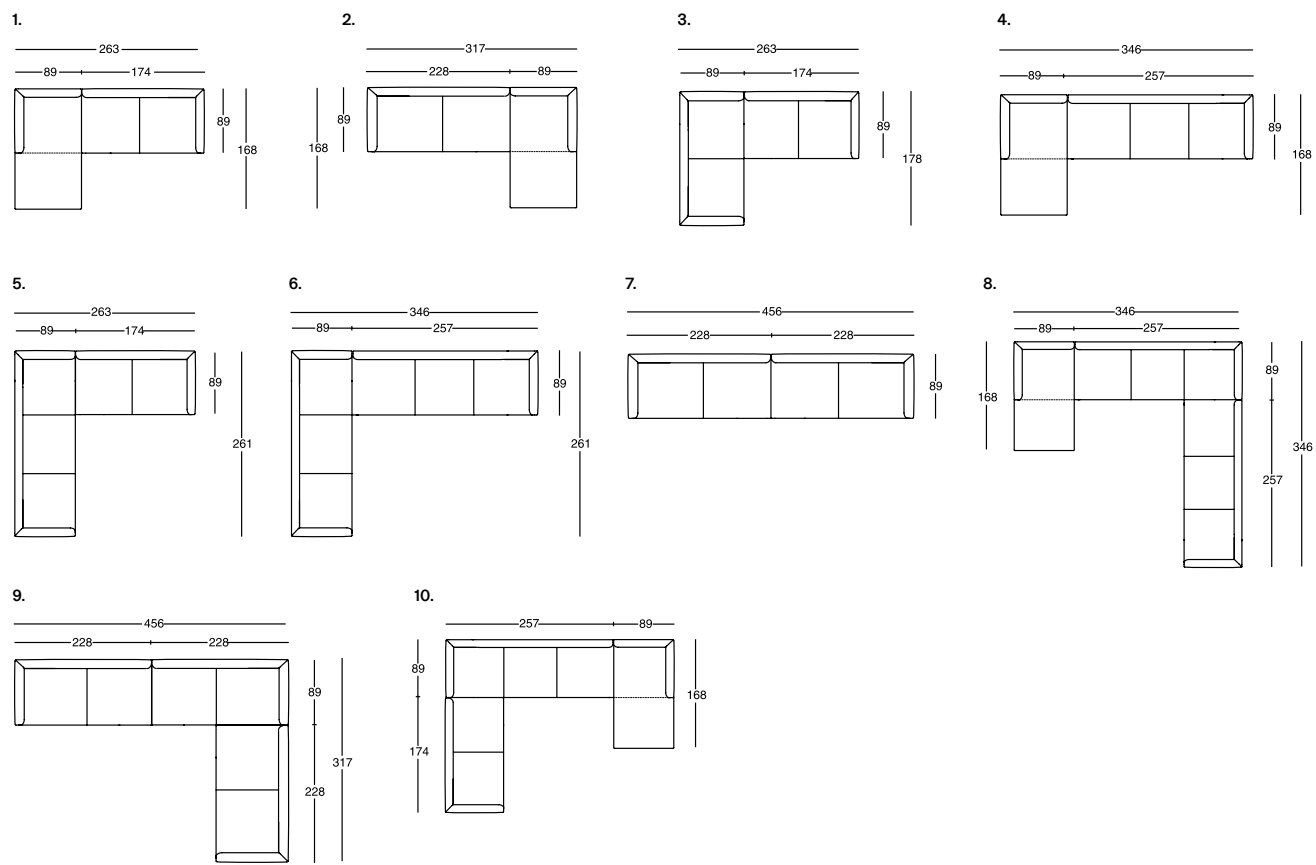

Kilt ¹²⁴²

Kilt 84 ¹²⁴³



Design

Emaf Progetti

2006

Poltrona, divani monoblocco, componibili, pouf

Struttura in acciaio. Molleggio su nastri elastici. Imbottitura in poliuretano/ fibra poliestere termolegata. Rivestimento con cuscino seduta trapuntato, sfilabile, in stoffa o in pelle.

Armchair, monobloc, modular sofas, pouf

Steel frame. Elastic strips suspension. Upholstery in polyurethane/heat-bound polyester fibre. Removable fabric or leather cover with quilted seat cushion.

Fauteuil, canapés monoblocs, composables, pouf

Structure en acier. Suspensions sur sangles élastiques. Rembourrage en polyuréthane/fibre polyester liée à chaud. Revêtement avec coussin assise surpiqué, déhoussable en tissu ou en cuir.

Sessel, einteilige, zusammenstellbare Sofas, Hocker

Stahlgestell. Federung mit elastischen Gurten. Polsterung aus Polyurethan/wärmegebundener Polyesterfaser. Abnehmbarer Bezug mit Steppung über den Sitzpolstern aus Stoff oder Leder.

Butaca, sofás monobloque, modulares, pouf

Estructura de acero. Asiento sobre cintas elásticas. Acolchado de poliuretano/ fibra poliéster termounida. Tapizado con cojín del asiento respunteado, desenfundable, de tejido o de piel.

1242/202

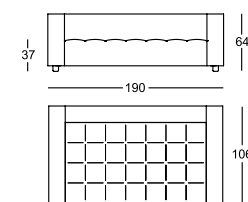

1242/212

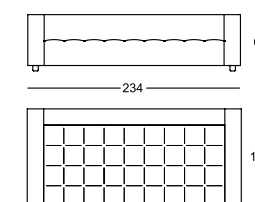

1242/302

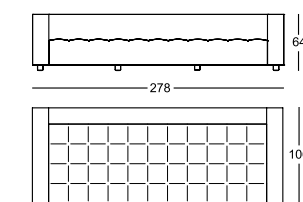

1242/301P

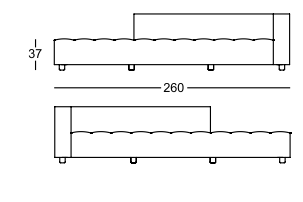

1242/PUF

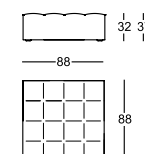

1242/201

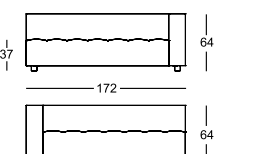

1242/211

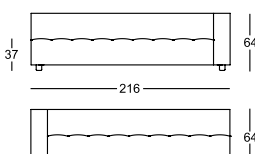

1242/301

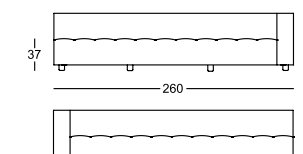

1242/ALPIS-ALP1D

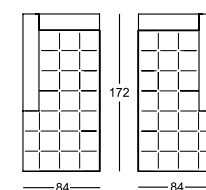

1242/ALIS-AL1D

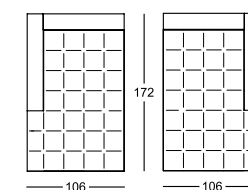



1243/102

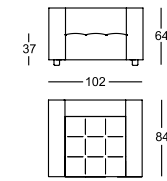

1243/202

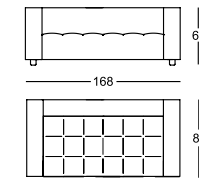

1243/212

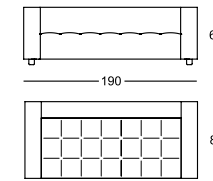

1243/302

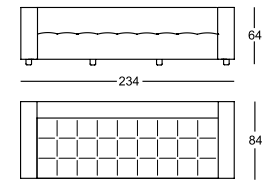

1243/201

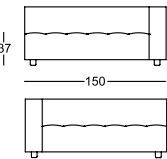

1243/211

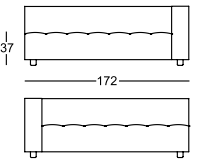

1243/301

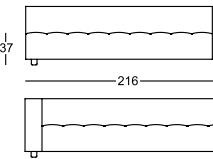

1243/301P

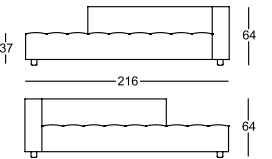

1243/ALPIS-ALPID

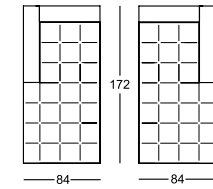

1243/ALIS-ALID

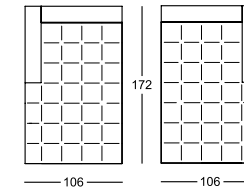

1244/C

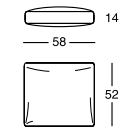

1245/C

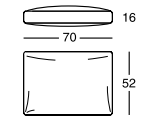

1.

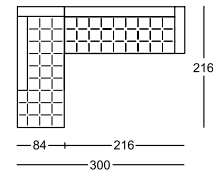

2.

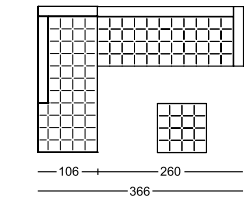

3.

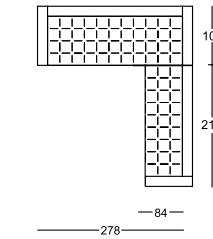

4.

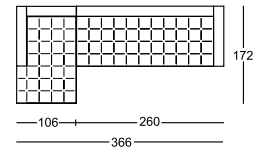

5.

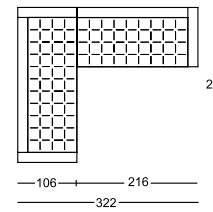

6.

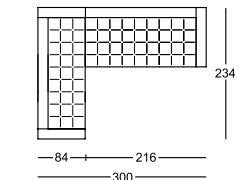

7.

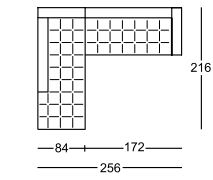

8.

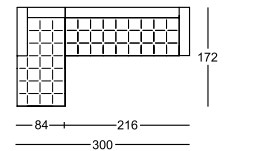

9.

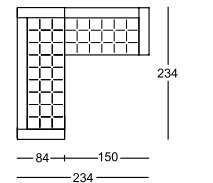

10.

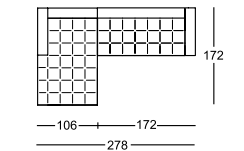

11.

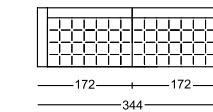

12.

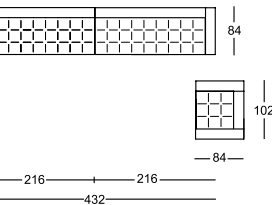

13.

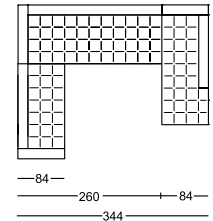

14.

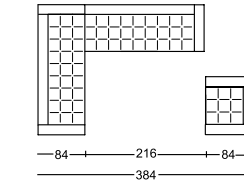

15.

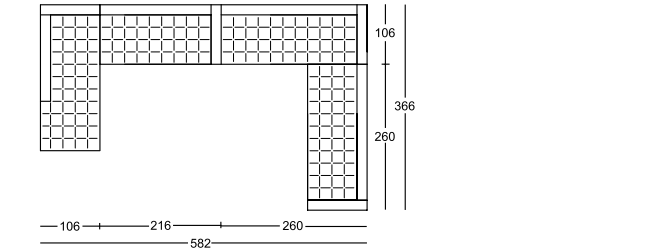



Design

De Pas, D'Urbino, Lomazzi

1982-2019

Divani monoblocco, componibili e pouf

Piedini in lega di alluminio nichel-satinato colore naturale o nero. Struttura in acciaio. Molleggio su nastri elastici. Cuscino seduta unico in poliuretano/fibra poliester termolegata; cuscini schienale e braccioli in fibra poliester. Rivestimento sfilabile in stoffa o in pelle.

Monobloc, modular sofas and pouf

Aluminum alloy feet, with natural or black nickel-satin finish. Steel frame. Elastic strips suspension. Single seat cushion in polyurethane/heat-bound polyester fibre; backrest cushions and armrests in polyester fibre. Removable fabric or leather cover.

Canapés monoblocs, composables et pouf

Pieds en alliage d'aluminium nickel satiné dans les finitions naturelle ou noire. Structure en acier. Suspension sur sangles élastiques. Coussin siège d'une seule pièce en polyuréthane/fibre de polyester liée à chaud; coussins dossier et accoudoirs fibre de polyester. Revêtement déhoussable en tissu ou en cuir.

Einteilige, zusammenstellbare Sofas und Hocker

Füße aus Alu-Legierung, mit naturfarben- oder schwarz- vernickeltem und mattiertem Finish. Gestell aus Stahl. Federung mit elastischen Gurten. Einteilige Sitzpolsterung aus Polyurethan/wärmegebundener Polyesterfaser; Rückenissen und Armlehnen aus Polyesterfaser. Abnehmbarer Bezug aus Stoff oder Leder.

Sofás monobloque, modulares y puf

Patas de aleación de aluminio niquelado mate en los acabados natural o negro. Estructura de acero. Asiento sobre cintas elásticas. Cojín de asiento único de poliuretano/fibra poliéster termounida; cojines de respaldo y apoyabrazos de fibra de poliéster. Tapizado desenfundable de tejido o de piel.

1039/212

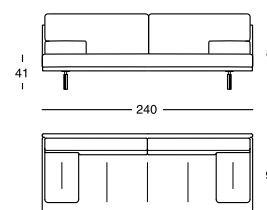

1039/302

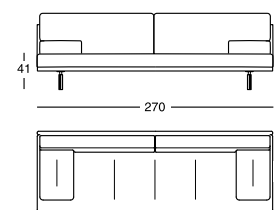

1039/PUF

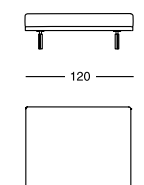

1039/211

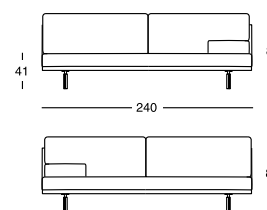

1039/301

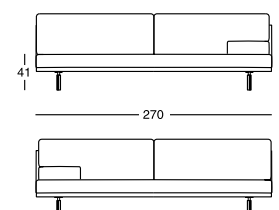

1039/AL1

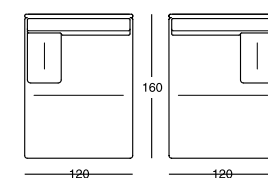

1.



2.

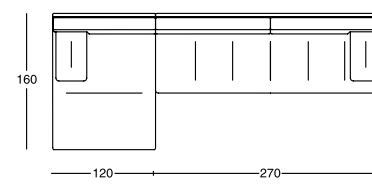

3.

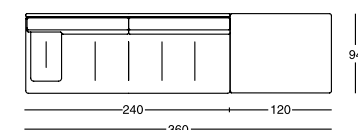

4.

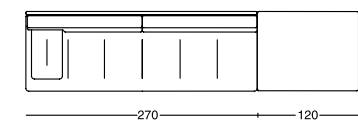

Piedini/Feet/Pieds/Füße/Patas





Design

Damian Williamson

2022

Divani monoblocco, componibili rettilinei e curvi con bracciolo o vassoio, pouf

Piedini in acciaio nichelsatinato nero opaco oppure verniciato colore grafite. Struttura in acciaio. Molleggio su nastri elastici. Cuscino seduta unico in poliuretano/fiocchi di poliesteri rigenerato e rigenerabile. Cuscino schienale in piuma d'oca – materiale 100% vergine. Cuscino bracciolo in fiocchi di poliesteri rigenerato e rigenerabile. Gli elementi terminali rettilinei e curvi possono essere dotati di cuscino bracciolo oppure essere attrezzati con un

vassoio in legno massello di frassino verniciato nero poro aperto opaco sulla base portante del divano. Rivestimento sfilabile in stoffa o in pelle. È disponibile un vassoio circolare Ø 45 cm in legno massello di frassino verniciato nero poro aperto opaco che può essere appoggiato liberamente sui cuscini di seduta. I pannelli perimetrali sono rivestiti nella stessa stoffa o pelle dei cuscini.

Monobloc, straight and curved modular sofas with armrest or tray, pouf

Steel feet, with matt black nickelsatin finish or varnished graphite. Steel frame. Elastic strips suspension. Single-piece seat cushion in polyurethane/regenerated and regenerable polyester flakes. Back cushion in 100% new goose feathers. Armrest cushion in regenerated and regenerable polyester flakes. The straight and curved end-sofas can be equipped with an armrest cushion or with a tray, made of solid matt black painted ash with open pore, placed on the supporting base of the sofa. Removable fabric or leather cover. One

round-shaped tray, diameter 45 cm, made of solid matt black painted ash with open pore, is available and can be placed as desired on the seat cushions. The side panels are covered in the same fabric or leather as the cushions.

Canapés monoblocs, composables rectilignes et incurvés avec accoudoir ou plateau, pouf

Pieds en acier nickel-satiné noir mat ou verni graphite. Structure en acier. Suspension sur sangles élastiques. Coussin assise dans une seule pièce en polyuréthane à densité variable/flocons de polyester régénérés et régénérables. Coussin dossier en plume d'oie - matériel 100% vierge. Coussin accoudoir en flocons de polyester régénérés et régénérables. Les éléments terminaux droits et courbes peuvent être équipés d'un coussin d'accoudoir ou être équipés

d'un plateau en bois de frêne massif verni noir mat à pores ouverts sur la base de support du canapé. Revêtement déhoussable en tissu ou en cuir. Un plateau circulaire Ø 45 cm est disponible en bois de frêne massif verni noir mat à pores ouverts qui peut être placé librement sur les coussins d'assise. Les panneaux périmétriques sont recouverts du même tissu ou du même cuir que les coussins.

Einteilige, zusammenstellbare geradlinige oder gebogene Sofas mit Armlehne oder Tablett, Hocker

Stahl-Füße, in der schwarz vernickelten und matteden Ausführung oder Graphit lackiert. Stahl-Gestell. Federung mit elastischen Gurten. Einteiliges Sitzkissen aus Polyurethan mit unterschiedlicher Dichte/regenerierten und regenerierbaren Polyesterflocken. Rückenkissen aus 100% reinen Gänsefedern. Armlehnen Kissen aus regenerierten und regenerierbaren Polyesterflocken. Die

geradlinigen und gebogenen Endelemente können mit einem Armlehnen Kissen oder einem Tablett, aus massivem Eschenholz, matt offenporig schwarz lackiert, auf dem Traggestell des Sofas ausgestattet werden. Abnehmbarer Bezug aus Stoff oder Leder. Ein rundes Tablett, Durchmesser 45 cm., aus massivem Eschenholz, matt offenporig schwarz lackiert, ist lieferbar und kann wunschgemäß auf dem Sitzkissen gelegt werden. Die Seitenpaneele werden mit dem gleichen Stoff oder Leder wie die Kissen bezogen.

Sofás monobloque, modulares rectilíneos y curvos con apoyabrazos o bandeja, puf

Patatas de acero niquelado mate negro o pintado color grafite. Estructura de acero. Suspensión sobre cintas elásticas. Cojín de asiento único de poliuretano a densidades diferenciadas/ copos de poliéster regenerado y regenerable. Cojín de respaldo de pluma de ganso - material 100% virgen. Cojín apoyabrazo de copos de poliéster regenerado y regenerable. Los elementos terminales rectilíneos y curvos pueden equiparse con un cojín apoyabrazos o

equiparse con una bandeja en madera maciza de fresno pintada de negro poro abierto mate colocada en la estructura del sofá. Tapizado desenfundable de tejido o de piel. Una bandeja redonda de Ø 45 cm está disponible en madera maciza de fresno pintada mate de poro abierto negro que se puede colocar libremente sobre los cojines de asiento. Los paneles perimetrales están tapizados en el mismo tejido o piel de los cojines.

Piedini/Feet/Pieds/Füße/Patas





1345/202

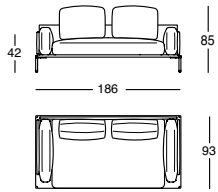

1345/212

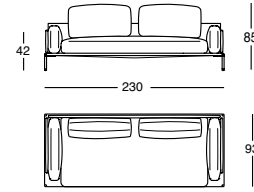

1345/302

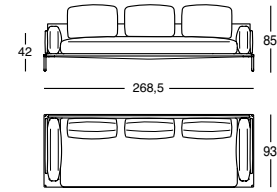

1345/POUF

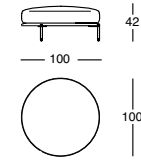

1345/201

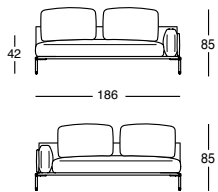

1345/211

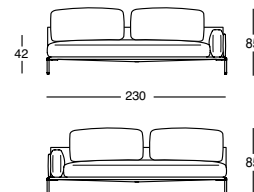

1345/301

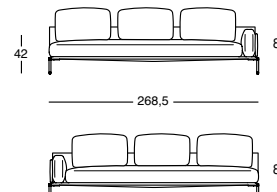

1345/301T

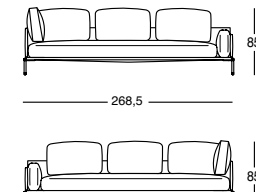

1345/AL1

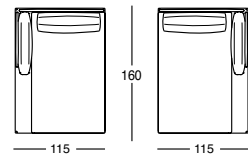

1345/300PANG

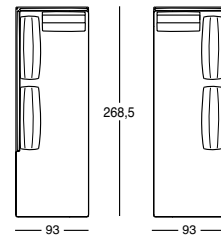

1345/211V

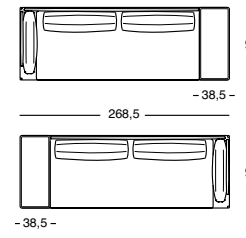

1345/210V

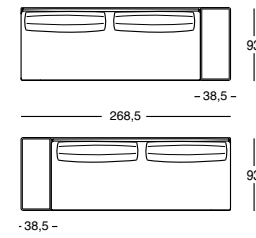

1345/201C

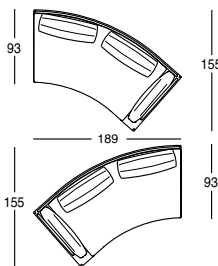

1345/200CV

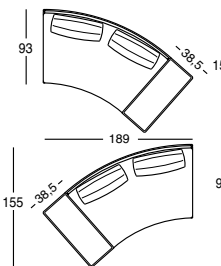

1345/VD45

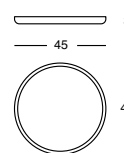

1.

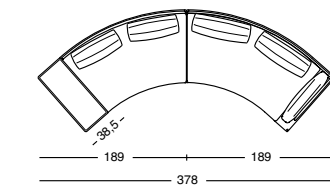

2.

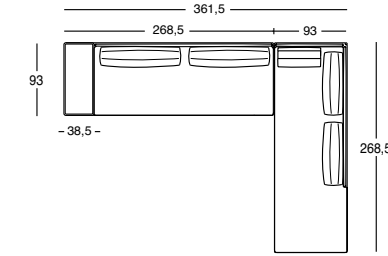

3.

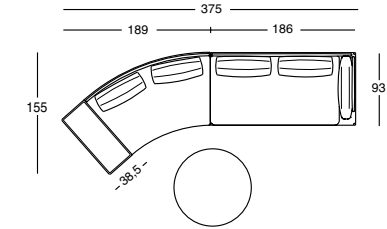

4.

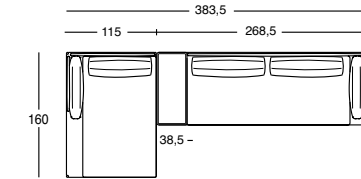

5.

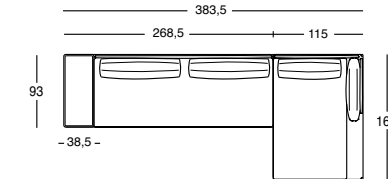

6.

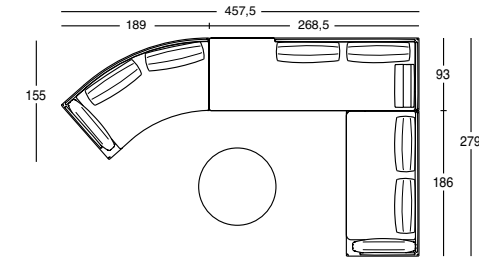

7.

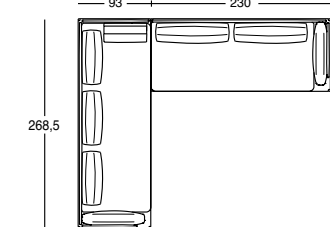

8.

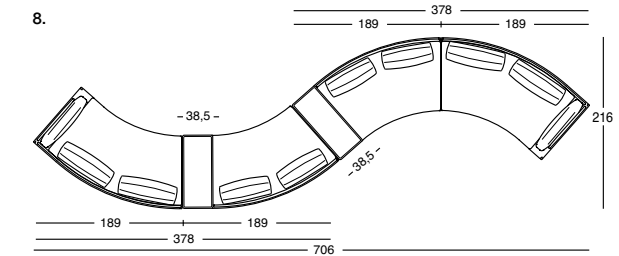

9.

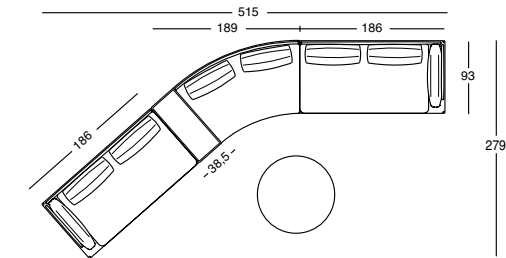

10.

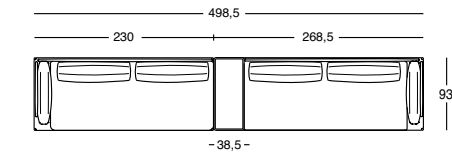



Design

De Pas, D'Urbino, Lomazzi

1985

Poltrona e divani monoblocco

Struttura portante in tubo di acciaio inox. Imbottitura in poliuretano/fibra poliestere termolegata. Rivestimento sfilabile in stoffa o in pelle. La sfoderabilità è resa possibile solamente da personale specializzato.

Armchair and monobloc sofas

Stainless steel tubular frame. Upholstery in polyurethane/heat-bound polyester fibre. Removable fabric or leather cover. The cover can be removed only by skilled staff.

Fauteuil et canapés monoblocs

Structure portante en tube d'acier inox. Rembourrage en polyuréthane fibre polyester liée à chaud. Revêtement déhoussable en tissu ou en cuir. Il est possible de déhousser le canapé seulement par un personnel spécialisé.

Sessel und einteilige Sofas

Tragendes Gestell aus Inox-Stahlrohr. Polsterung aus Polyurethan/wärmegebundener Polyesterfaser. Abnehmbarer Bezug aus Stoff oder Leder. Der Bezug kann nur vom Fachpersonal abgenommen werden.

Butaca y sofás monobloque

Estructura portante de tubo de acero inox. Acolchado de poliuretano/fibra poliéster termounida. Tapizado desenfundable de tejido o de piel. Es posible quitar la funda solo de personal especializado.

1030/102

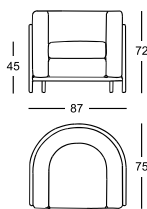

1030/202

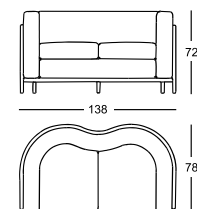

1030/302

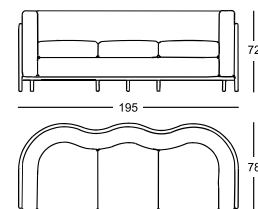

Design

Emaf Progetti

2011

IN/OUT

Divani monoblocco e pouf per esterni

Struttura portante in acciaio verniciato per esterni, colore talco o nero. Molleggio su nastri elastici. Cuscini seduta, schienale e bracciolo in poliuretano reticolato a cellula aperta/Paineira, fibra vegetale idrorepellente. Rivestimento sfilabile in tessuto Talasso.

Monobloc sofas and pouf for outdoor use

Supporting frame in painted steel for outdoor use in the shade of talc or black. Elastic strips suspension. Seat, back and armrest cushion in open cell reticulated polyether/Paineira, water-repellent vegetal fibre. Removable cover in fabric Talasso.

Canapés monoblocs et pouf pour extérieur

Structure portante en acier verni pour extérieurs, couleur talc ou noir. Suspension sur sangles élastiques. Coussins d'assise, dossier et accoudoir en polyéther réticulé à cellule ouverte/Paineira, fibre végétale hydrofuge. Revêtement déhoussable en tissu Talasso.

Einteilige Sofas und Hocker fürs Freie

Tragendes Gestell mit Lackierung fürs Freie, in den Farben Talkum oder schwarz. Federung auf elastischen Gurten. Sitzkissen, Rücken und Armlehne aus vernetztem Polyether mit offenen Zellen/Paineira, Pflanzenfaser, wasserabweisend. Abnehmbarer Bezug aus Stoff Talasso.

Sofás monobloque y pouf para exteriores

Estructura portante de acero barnizada para exteriores color talco o negro. Suspensión sobre cintas elásticas. Cojines de asiento, respaldo y apoyabrazo de poliéther reticulado con célula abierta/Paineira, fibra vegetal hidropelente. Tapizado desenfundable de tejido Talasso.

Struttura/Frame/Structure/Gestell/Estructura



1034/202

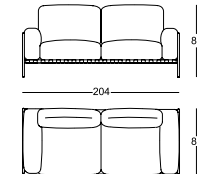

1034/212

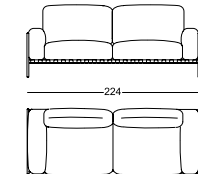

1034/302

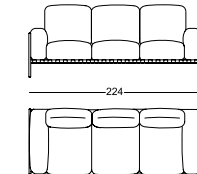

1034/312

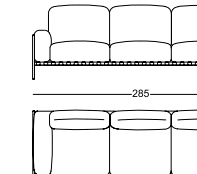

1034/402

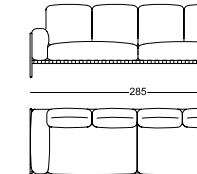

1034/PUF

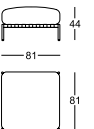

Pianoalto ¹²⁷²

Pianoalto 96 ¹²⁷³



Design

Ludovica+Roberto Palomba

2012

Divani monoblocco, componibili, pouf

Piedini in acciaio verniciati colore grafite. Struttura in legno. Molleggio su nastri elastici. Imbottitura sedile in poliuretano/Dacron Du Pont con inserto trapuntato in piuma d'oca. Imbottitura schienale e braccioli in poliuretano/Dacron Du Pont con inserto trapuntato in piuma d'oca e fiocchi di fibra poliestere. Imbottitura cuscini schienale in poliuretano/Dacron Du Pont o in piuma d'oca. Rivestimento sfilabile in stoffa o in pelle.

Monobloc and modular sofas, pouf

Graphite painted steel feet. Wooden frame. Elastic strips suspension. Seat upholstered in polyurethane/Dacron Du Pont with quilted insert of goose feathers. Backrest and armrests upholstered in polyurethane/Dacron Du Pont with quilted insert of goose feathers and polyester fibre flakes. Back cushions upholstered in polyurethane/Dacron Du Pont or in goose feathers. Removable cover in fabric or leather.

Canapés monoblocs, composables, pouf

Pieds en acier verni graphite. Structure en bois. Suspension sur sangles élastiques. Rembourrage de l'assise en polyuréthane / Dacron Du Pont avec insertion matelassé en plume d'oie. Rembourrage du dossier et des accoudoirs en polyuréthane/Dacron Du Pont avec insertion matelassé en plume d'oie et flocons de fibre polyester. Rembourrage des coussins du dossier en polyuréthane/Dacron Du Pont ou en plume d'oie. Revêtement déhoussable en tissu ou en cuir.

Einteilige, zusammenstellbare Sofas, Hocker

Füße aus graphitfarben lackiertem Stahl. Gestell aus Holz. Federung auf elastischen Gurten. Sitzpolsterung aus Polyurethan/Dacron Du Pont mit Steppeinsatz aus Gänsefedern. Polsterung von Arm- Rückenlehne aus Polyurethan/Dacron Du Pont mit Steppeinsatz aus Gänsefedern und Flocken aus Polyesterfasern. Polsterung der Rückenissen aus Polyurethan/Dacron Du Pont oder aus Gänsefedern. Abnehmbarer Bezug aus Stoff oder Leder.

Sofás monobloques, modulares, pouf

Pies de acero lacados en grafito. Estructura de madera. Suspensión con cintas elásticas. Asiento acolchado de poliuretano/Dacron Du Pont con inserción de pluma de ganso. Respaldo y brazos acolchados de poliuretano/Dacron Du Pont con inserción de pluma de ganso y copos de fibra de poliéster. Cojines de respaldo acolchados de poliuretano/Dacron Du Pont o pluma de ganso. Tapizado desenfundable de tejido o piel.

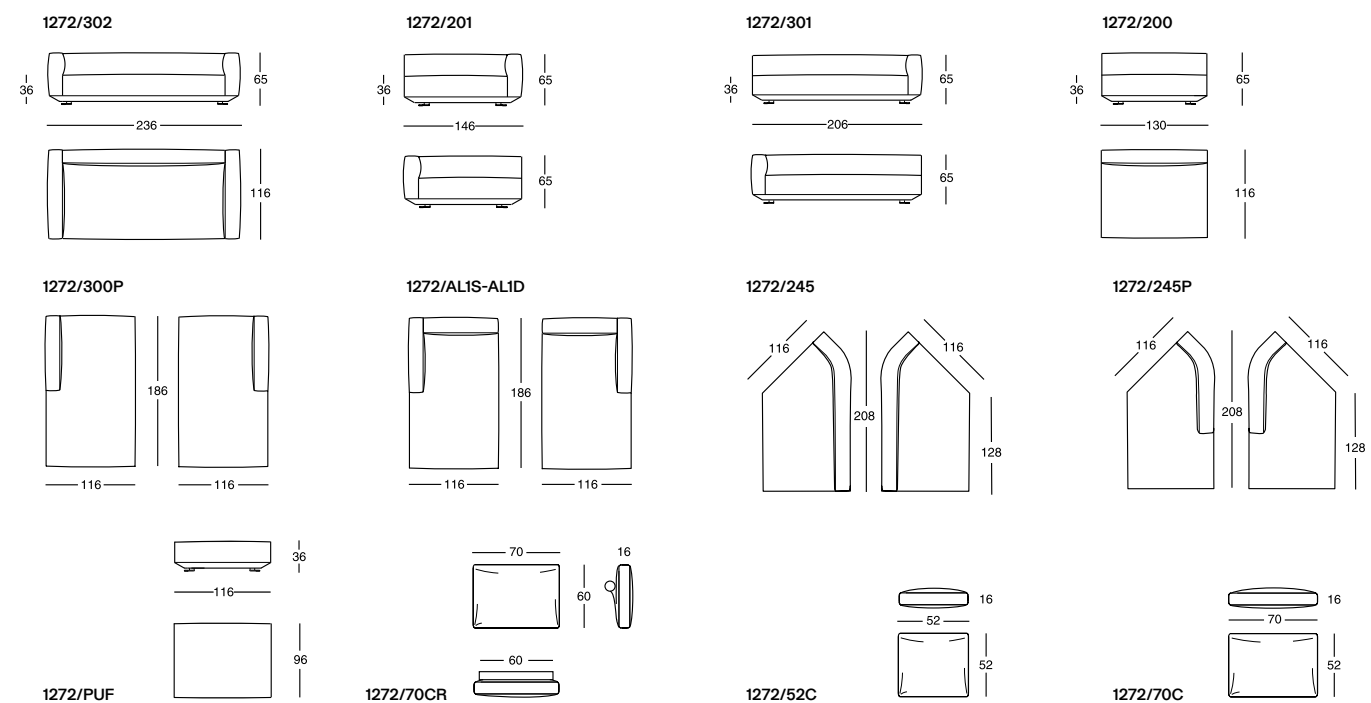



1273/212

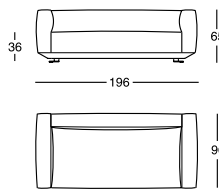

1273/302

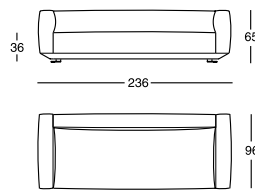

1273/201

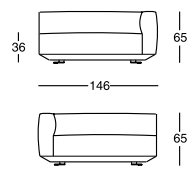

1273/301

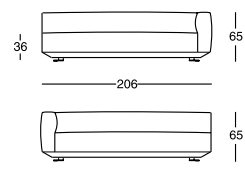

1273/300P

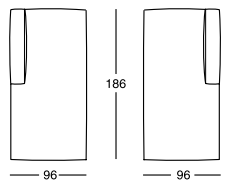

1273/ALIS-ALID

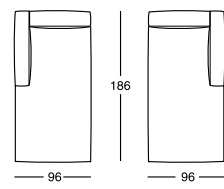

1273/200

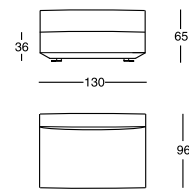

1272/PUF

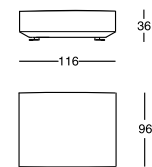

1273/52C

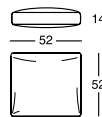

1273/70C

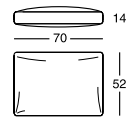

1.

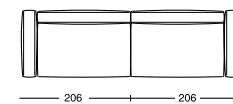

2.

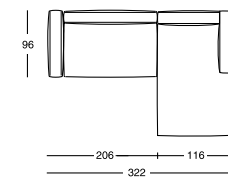

3.

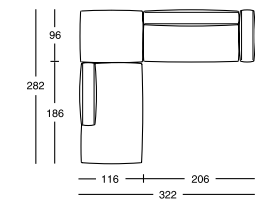

4.

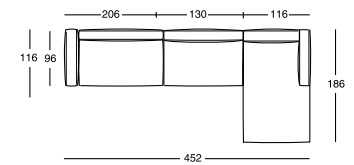

5.

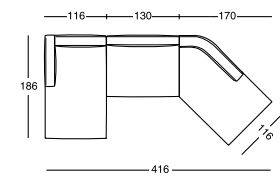

6.

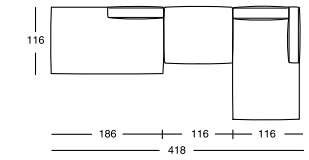

7.

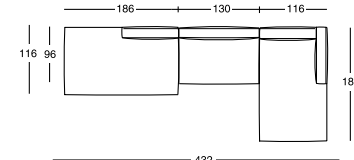

8.

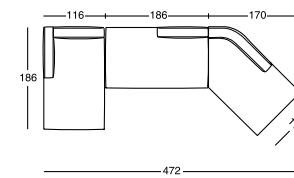

9.

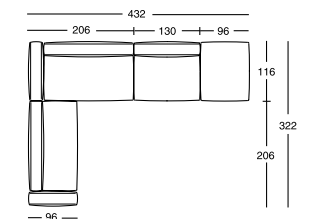

10.

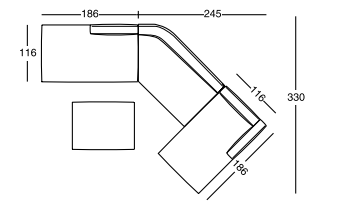



Design

Damian Williamson

2019

Divani monoblocco e componibili

Base in legno rivestita nello stesso tessuto o pelle del divano. Struttura in legno. Molleggio su nastri elastici. Imbottitura schienale e sedile in poliuretano/fibra poliestere termolegata. Cuscino schienale in piuma d'oca - materiale 100% vergine. Cuscino a rullo in poliuretano/fibra poliestere termolegata.

Rivestimento con cuscino seduta trapuntato, sfilabile in stoffa o in pelle. A richiesta, per i divani monoblocco, è disponibile la versione con tutti gli schienali alti.

Monobloc and modular sofas

Wooden base covered with the same fabric or leather of the sofa. Wooden frame. Elastic strips suspension. Backrest and seat upholstered with polyurethane/heat-bound polyester fibre. Backrest cushion in 100% new goose feathers. Roll-shaped cushion in polyurethane/heat-bound polyester fibre.

Removable fabric or leather cover with quilted seat cushion. Upon request, only for the monobloc sofas, the version with all higher backrests is available.

Canapés monoblocs et composables

Embasement en bois revêtu dans le même tissu ou cuir du canapé. Structure en bois. Suspension sur sangles élastiques. Rembourrage du dossier et du siège en polyuréthane / fibre de polyester liée à chaud. Coussin dossier en plume d'oie - matériel 100% vierge. Coussin cale-reins en polyuréthane/fibre polyester

liée à chaud. Revêtement avec coussin siege surpiqué, déhoussable en tissu ou en cuir. Sur demande, pour les canapés monoblocs, il est disponible une version avec tous les dossiers hauts.

Einteilige und zusammenstellbare Sofas

Holzsockel mit dem gleichen Stoff oder Leder Bezug des Sofas. Holzgestell. Federung mit elastischen Gurten. Polsterung der Rückenlehne und Sitz aus Polyurethan/ wärmegebundener Polyesterfaser. Rückenkissen mit 100% reinen Gänsefedern. Nierenrolle-Kissen

aus Polyurethan/ wärmegebundener Polyesterfaser. Abnehmbarer Bezug mit Steppung über den Sitzpolstern aus Stoff oder Leder. Auf Nachfrage, nur für die einteilige Sofas, ist die Ausführung mit allen höhen Rückenlehnen verfügbar.

Sofás monobloque y modulares

Base en madera tapizada con el mismo tejido o piel del sofá. Estructura en madera. Suspensión sobre cintas elásticas. Acolchado del respaldo y del asiento en poliuretano/fibra poliéster termounida. Cojín de respaldo en pluma de ganso, material 100% virgen. Cojín lumbar en poliuretano/

fibra poliéster termounida. Tapizado con cojín de asiento respunteado, desenfundable de tejido o de piel. Sobre pedido, para los sofás monobloque, está disponible la versión con los respaldos altos.

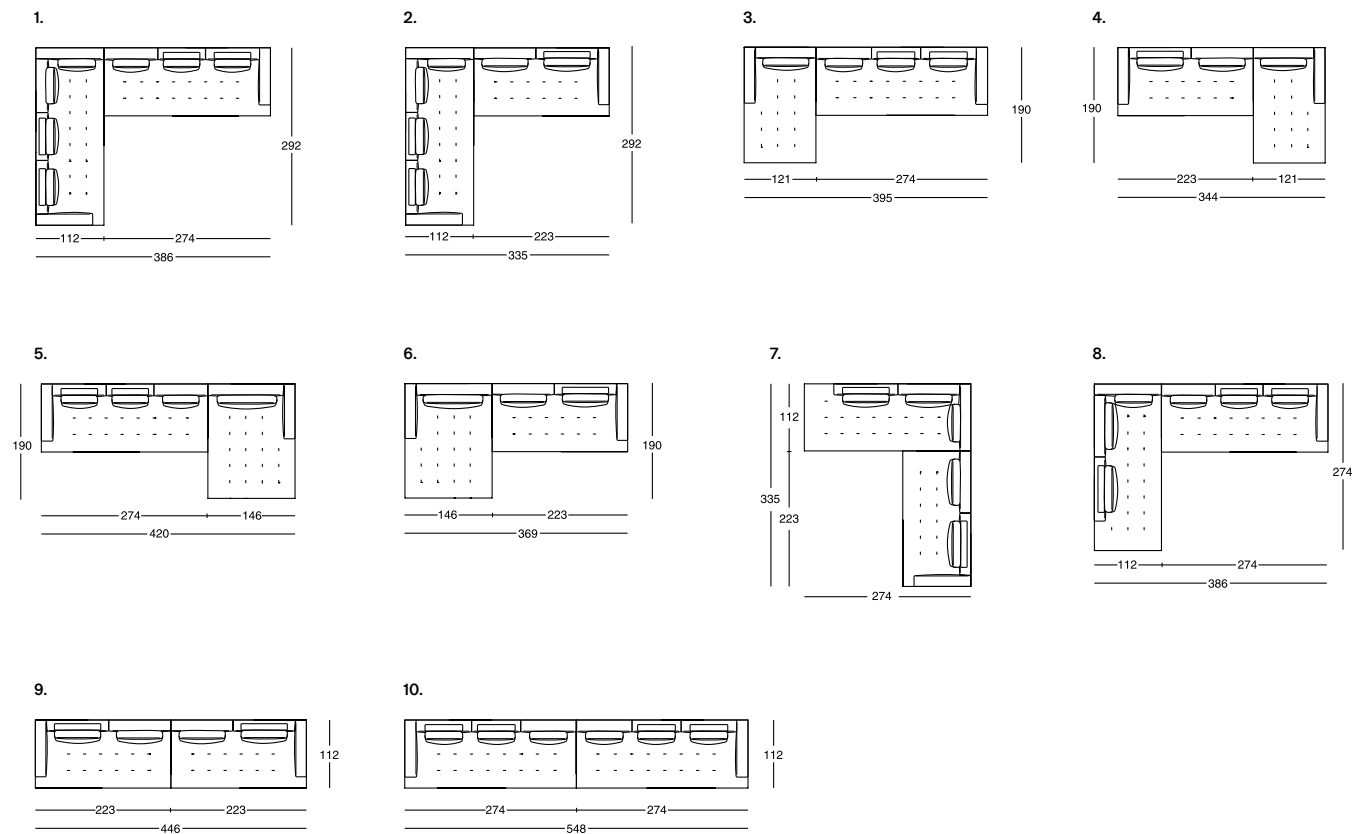
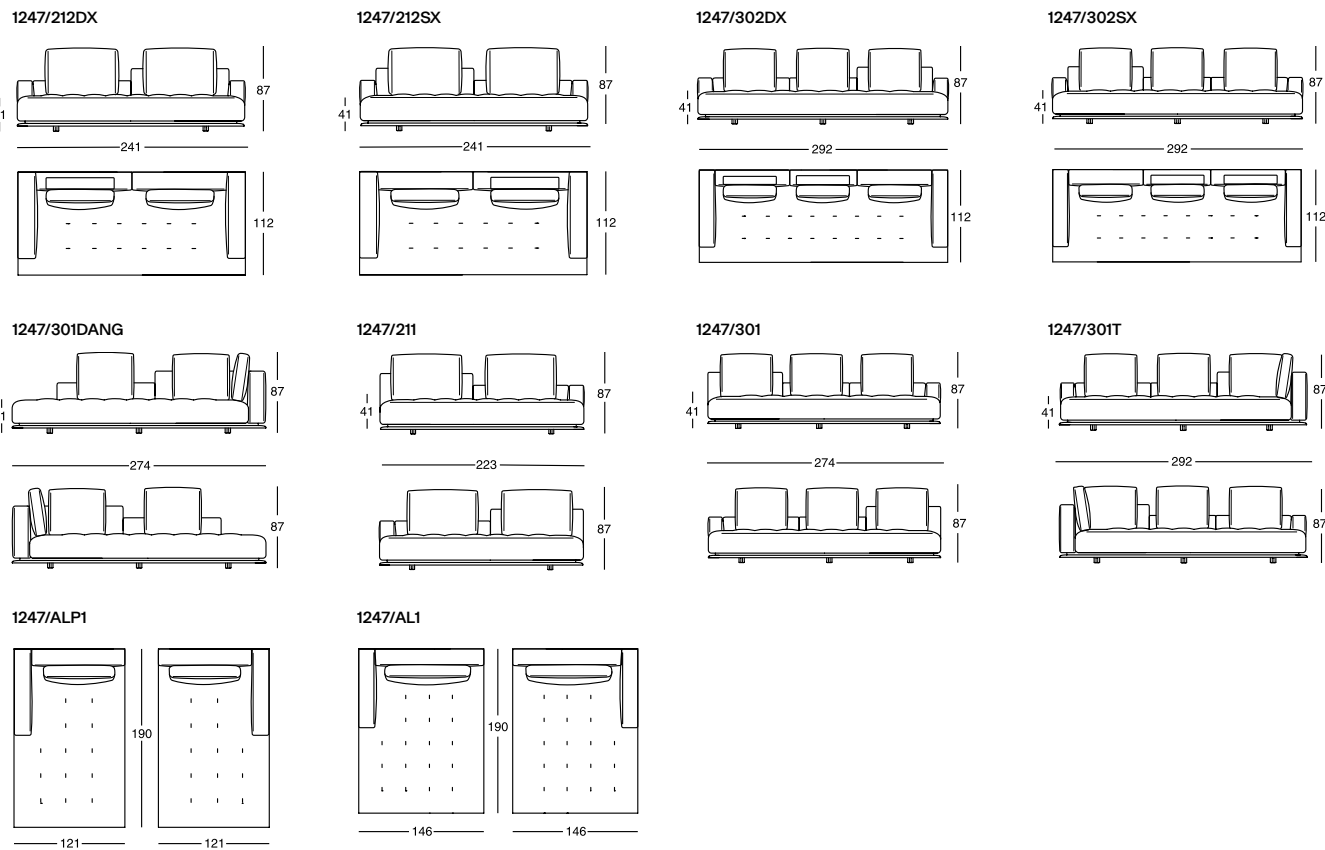

Throw-Away¹¹⁵⁰



Design

Willie Landels

1965

Poltrona, divani e pouf
Struttura in poliuretano espanso. Rivestimento sfilabile in stoffa o in pelle.

Armchair, sofas and pouf
Expanded polyurethane frame. Removable cover in fabric or leather.

Fauteuil, canapés et pouf
Structure en polyurethane expansé. Revêtement déhoussable en tissu ou en cuir.

Sessel, Sofas und Hocker
Gestell aus Polyurethan-Schaum. Abnehmbarer Bezug aus Stoff oder Leder.

Butaca, sofás y puf
Estructura de poliuretano espanso. Tapizado desenfundable de tejido o de piel.



1150/102

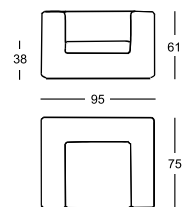

1150/202

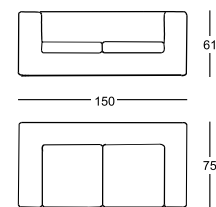

1150/302

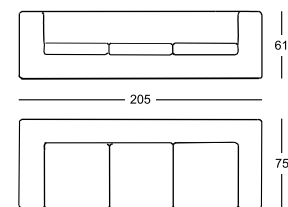

1150/PUF

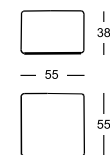



Design

Damian Williamson

2010-2015

Poltrona, divani monoblocco, componibili, pouf, dormeuse e mensole
Piedini in lega di alluminio lucidato, nichelsatinato colore naturale o nero, oppure verniciato nero. Struttura in acciaio. Molleggio su nastri elastici. Imbottitura in poliuretano/ fibra poliestere termolegata. Cuscini seduta, schienale e bracciolo in piuma d'oca. Rivestimento sfilabile in stoffa o in pelle. Le poltrone allungate senza bracciolo e i divani terminali sono predisposti per l'attacco

di una mensola in legno massello di rovere verniciato colore naturale o tinto grigio oppure in noce Canaletto verniciato colore naturale. Reggi-mensola in alluminio lucidato, nichelsatinato colore naturale o nero, o verniciato nero.

Armchair, monobloc, modular sofas, pouf, day bed and shelves
Aluminum alloy feet, either polished or with natural or black nickel-satin finish, or black painted. Steel frame. Elastic strips suspension. Upholstery in polyurethane/ heat-bound polyester fibre. Seat, back and armrest cushions upholstered with goose down. Removable fabric or leather cover. The lounge chairs without armrest and the end-sofas are fit to arrange a solid wood shelf, in natural or grey

painting oak or in natural painted Canaletto walnut. Shelf supports in polished, with natural or black nickel-satin finish, or black painted aluminum.

Fauteuil, canapés monoblocs, composables, pouf, dormeuse et étagères
Pieds en alliage d'aluminium poli, ou nickel-satiné, dans les couleurs naturel ou noir, ou verni noir. Piètement en acier. Suspension sur sangles élastiques. Rembourrage en polyuréthane/fibre polyester liée à chaud. Coussins d'assise, dossier et accoudoirs en plume d'oie. Revêtement déhoussable en tissu ou en cuir. Les fauteuils allongés sans accoudoir et

les canapés composables sont prédisposés pour l'accrochage d'une étagère en bois massif rovere verni naturel ou teinté gris ou en noyer Canaletto verni naturel. Supports d'étagère en aluminium poli, ou nickel satiné, dans les couleurs naturel ou noir, ou verni noir.

Sessel, einteilige, zusammenstellbare Sofas, Hocker, Liege und Stützfläche
Füße aus polierter Aluminiumlegierung, oder mit naturfarben- oder schwarz vernickeltem und mattiertem Finish, oder schwarz lackiert. Gestell aus Stahl. Federung auf elastischen Gurten. Polsterung aus Polyurethan/ wärmegebundener Polyesterfaser. Sitz-, Rücken und Armlehnen-Polsterung aus Gänsefedern. Abnehmbarer Bezug aus

Stoff oder Leder. Die Liegesessel ohne Armlehne und die zusammenstellbaren Sofas werden zur Befestigung einer Stützfläche ausgestattet, die entweder aus Massivholz in naturfarbener oder graugebeizter Eiche oder in naturfarben lackiertem Nussbaum Canaletto erhältlich ist. Stützfläche-Träger aus poliertem Aluminium, oder mit naturfarben- oder schwarz vernickeltem und mattiertem Finish, oder schwarz lackiert.

Butaca, sofás monobloque, modulares, puf, butacas alargadas y repisas
Patatas de aleación de aluminio pulido o niquelado mate en los acabados natural o negro, o pintado negro. Estructura de acero. Suspensión sobre cintas elásticas. Acolchado de poliuretano/fibra poliéster termounida. Cojines asiento, respaldo y apoyabrazo de pluma de ganso. Tapizado desenfundable de tejido o de piel. Las butacas alargadas sin apoyabrazos y los sofás

modulares se preparan para fijar una repisa en madera maciza de roble pintado color natural o teñido gris, o en nogal Canaletto pintado color natural. Soportes de las repisas en aluminio pulido o niquelado mate en los acabados natural o negro, o pintado negro.

Piedini/Feet/Pieds/Füße/Patas



Reggi Mensole/Shelf supports/ Supports d'étagère/Stützfläche-Träger/ Soportes repisa



Rovere naturale/ Natural oakwood/ Rouvre naturel/ Naturfarbene Eiche/ Roble natural



Rovere tinto grigio/Grey varnished oak/ Rouvre teinté gris/Graugebeizte Eiche/ Roble teñido gris



Noce Canaletto/ Canaletto walnut/Noyer Canaletto/ Nussbaum Canaletto/Nogal Canaletto





1330/102

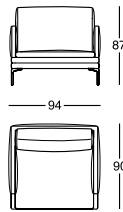

1330/202

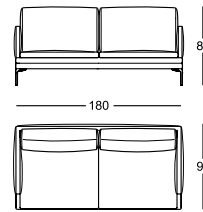

1330/212

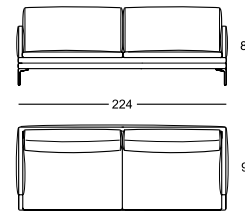

1330/302

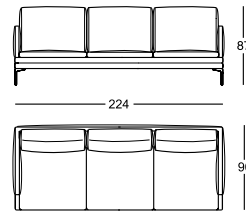

1330/312

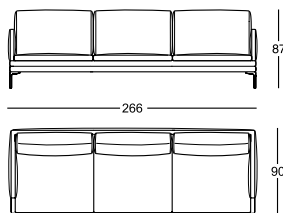

1330/201

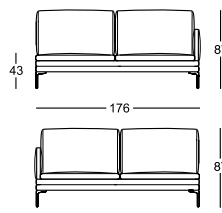

1330/211

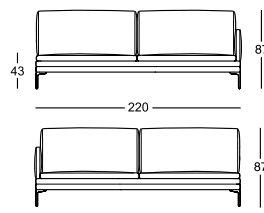

1330/301

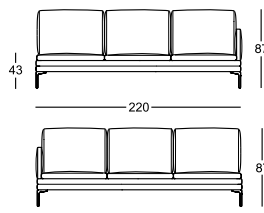

1330/M125

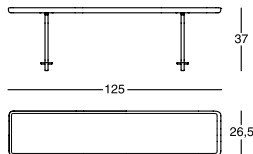

1330/M88

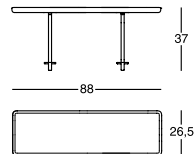

1330/M104

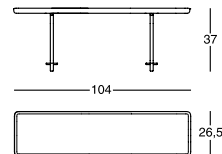

1330/311

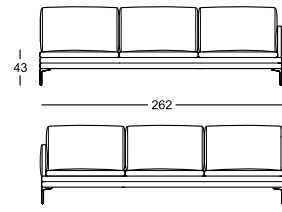

1330/301T

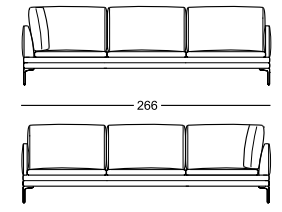

1330/AL1

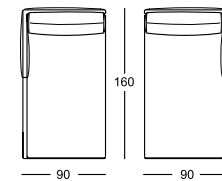

1330/DOR

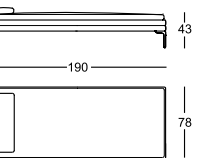

1330/AL2

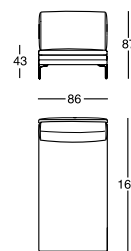

1330/AL3

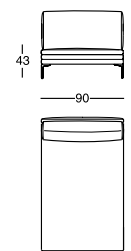

1330/AL4

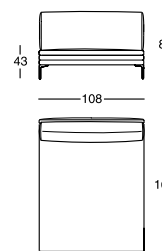

1330/210P

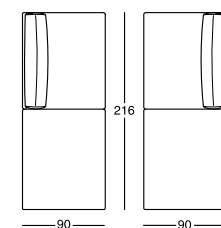

1330/210PANG

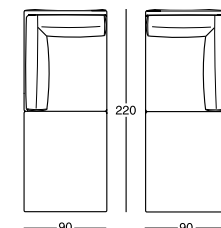

1330/211PT

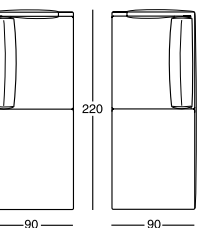

1330/PUF

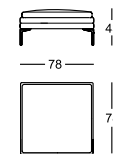

1330/BRA

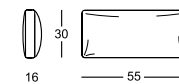

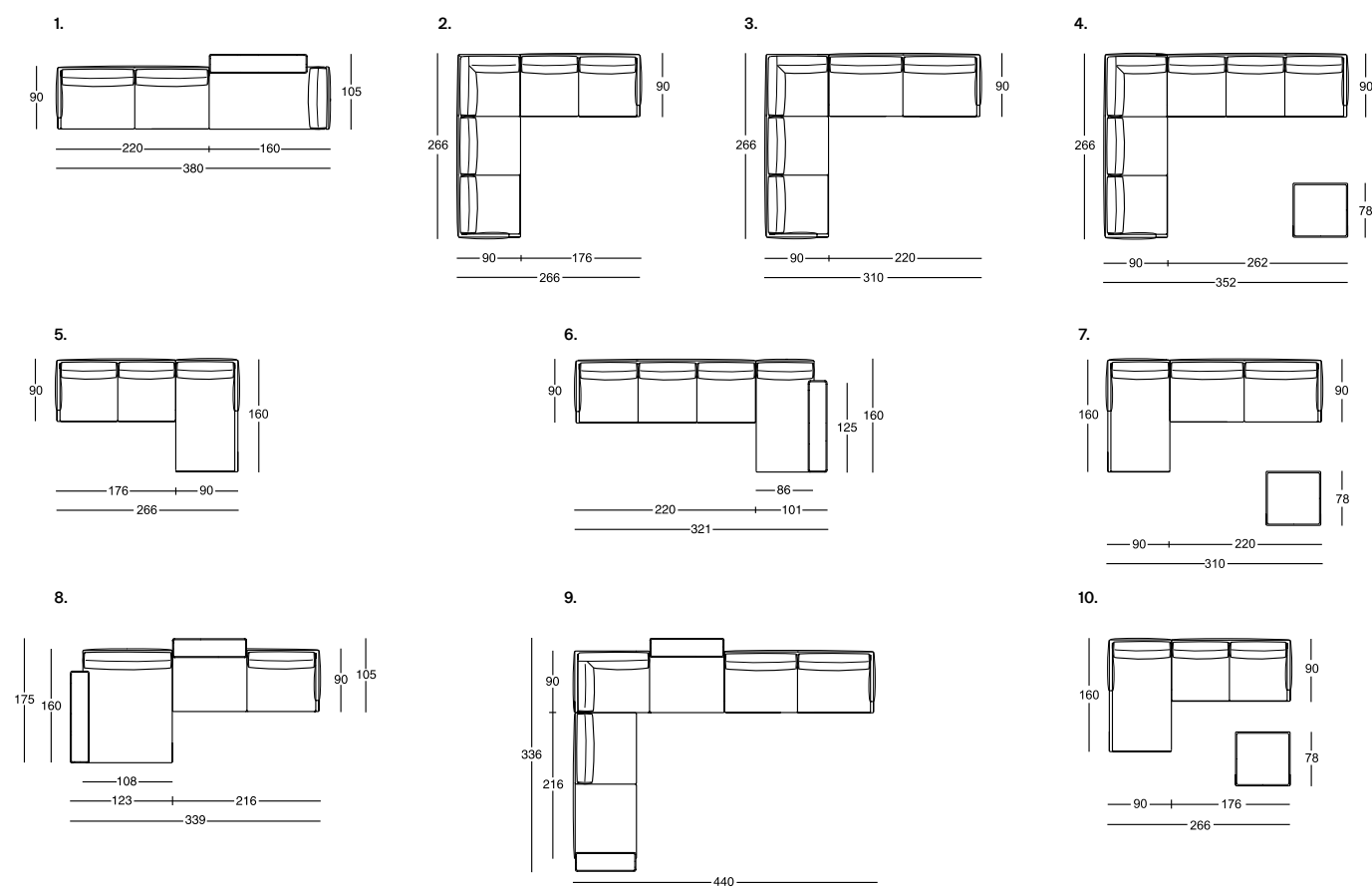



Design

Zaven

2024

Divani monoblocco, componibili e pouf.

Struttura portante in acciaio verniciato colore arancione, amaranto, verde prato o nero, dotata di nastri rigidi in poliestere colore antracite per il supporto dei cuscini. Cuscini seduta, schienale e bracciolo in poliuretano/ sfere di poliestere rigenerato e rigenerabile. Assemblaggio imbottiture privo di collanti. Rivestimento sfilabile in stoffa.

Monobloc, modular sofas and pouf.

Carrying frame in orange, amaranth, grass green or black painted steel, complete of stiff polyester straps in the shade anthracite for the support of the cushions. Seat, back and armrest cushions in polyurethane/ regenerated and regenerable polyester balls. Paddings assembly without glues. Removable fabric cover.

Canapés monoblocs, composables et pouf.

Structure porteuse en acier verni orange, rouge amarante, vert pré ou noir avec rubans rigides en polyester anthracite pour le soutien des coussins. Coussins d'assise, dossier et accoudoir en polyuréthane/ boules de polyester régénéré et régénérable. Assemblage du rembourrage sans adhésifs. Revêtement déhoussable en tissu.

Einteilige, zusammenstellbare Sofas und Hocker.

Traggestell aus orange, Amarantröt, grasgrün oder schwarz lackiertem Stahl mit steifen anthrazitfarbenen Polyesterbändern zur Unterstützung der Kissen. Sitz-Rücken und Armlehnen-Kissen aus Polyurethan/regenerierten Polyesterkugeln. Polstermontage ohne Klebstoffe. Abnehmbarer Bezug aus Stoff.

Sofás monobloque, modulares y púf.

Estructura portante en acero pintado en naranja, granate, verde prado o negro con cintas rígidas de poliéster antracita para el soporte de los cojines. Cojines de asiento, respaldo y apoyabrazos en copos de poliuretano/bolas de poliéster regenerado y regenerable. Montaje de los acolchados sin cola. Tapizado desenfundable de tejido.

Struttura/Frame/Structure/Gestell/
Estructura

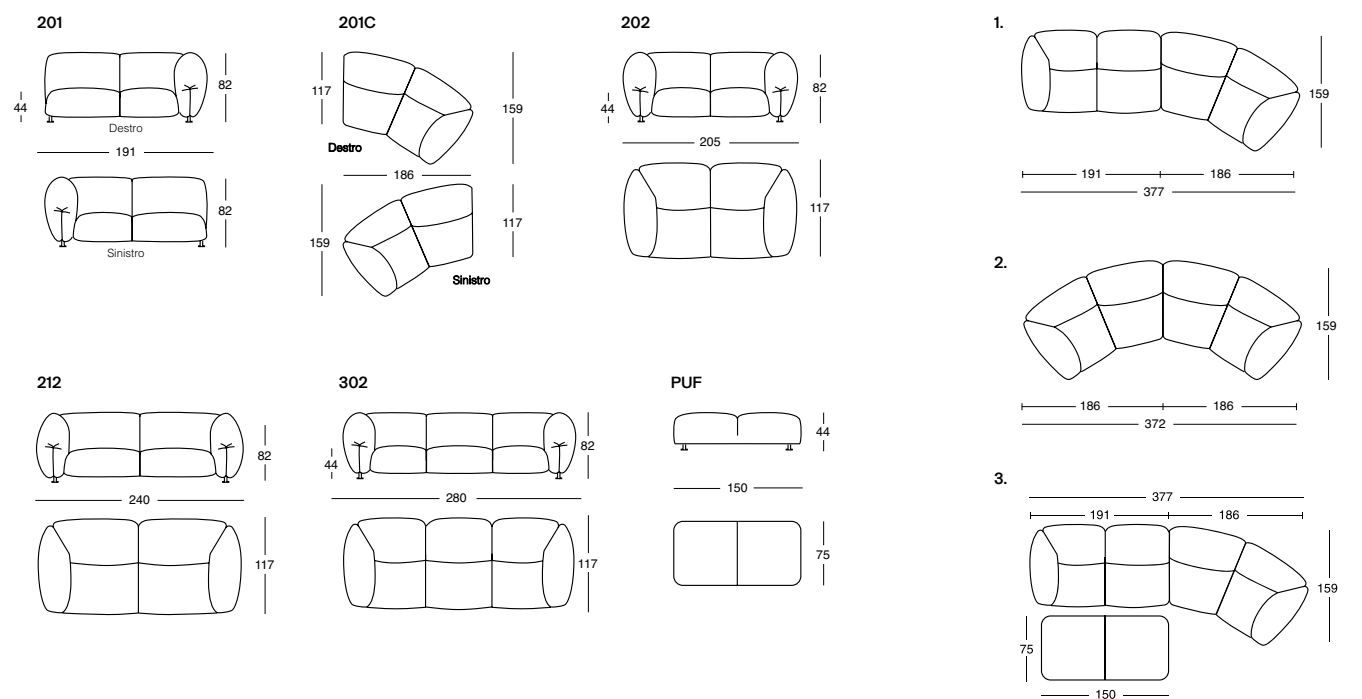



Design

Zaven

2022

Divani monoblocco

Struttura portante in acciaio verniciato colore arancione, amaranto, verde prato o nero dotata di nastri rigidi in poliestere colore antracite per il supporto dei cuscini. Cuscini seduta, schienale e bracciolo in poliuretano/ sfere di poliestere rigenerato e rigenerabile. Assemblaggio imbottiture privo di collanti. Rivestimento sfilabile in stoffa.

Monobloc sofas

Carrying frame in orange, amaranth, grass green or black painted steel, complete of stiff polyester straps in the shade anthracite for the support of the cushions. Seat, back and armrest cushions in polyurethane/ regenerated and regenerable polyester balls. Paddings assembly without glues. Removable fabric cover.

Canapés monoblocs

Structure porteuse en acier verni orange, rouge amarante, vert pré ou noir avec rubans rigides en polyester anthracite pour le soutien des coussins. Coussins d'assise, dossier et accouider en polyuréthane/ boules de polyester régénéré et régénérable. Assemblage du rembourrage sans adhésifs. Revêtement déhoussable en tissu.

Einteilige Sofas

Traggestell aus orange, Amaranth, grasgrün oder schwarz lackiertem Stahl mit steifen anthrazitfarbenen Polyesterbändern zur Unterstützung der Kissen. Sitz-Rücken und Armlehnen-Kissen aus Polyurethan/regenerierten und regenerierbaren Polyesterkugeln. Polstermontage ohne Klebstoffe. Abnehmbarer Bezug aus Stoff.

Sofás monobloque

Estructura portante en acero pintado en naranja, granate, verde prado o negro con cintas rígidas de poliéster antracita para el soporte de los cojines. Cojines de asiento, respaldo y apoyabrazos en copos de poliuretano/bolas de poliéster regenerado y regenerable. Montaje de los acolchados sin cola. Tapizado desenfundable de tejido.

1045/202

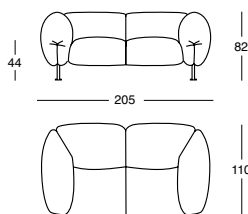

1045/212

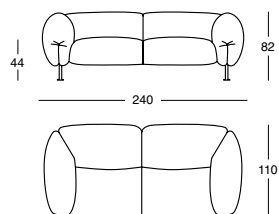

1045/302

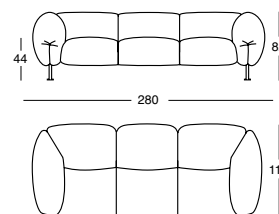

Struttura/Frame/Structure/Gestell/
Estructura



Poltrone
Armchairs
Fauteuils
Sessel
Butacas

Ardea CM⁸⁸²



Omaggio a

Carlo Mollino

1946

Poltrona/Bergère

Base in legno massello di rovere naturale o tinto nero oppure in legno massello di noce Canaletto colore naturale; verniciatura con finitura a cera. Struttura in acciaio con molleggio su nastri elastici. Imbottitura in poliuretano/fibra poliestere termolegata. Rivestimento sfilabile in stoffa o pelle.

Armchair/Bergère

Base in solid natural or black varnished oak, or in solid natural Canaletto walnut; wax-finished varnish. Steel frame, with elastic strips suspension. Upholstery in polyurethane/heat-bound polyester fibre. Removable cover in fabric or leather.

Fauteuil/bergère

Socle en rouvre naturel massif ou teinté noir ou en noyer Canaletto massif, couleur naturelle; verni finition cirée. Structure en acier avec suspension sur sangles élastiques. Rembourrage en polyuréthane/fibre de polyester liée à chaud. Revêtement déhoussable en tissu ou en cuir.

Sessel/Bergère

Sockel aus massiver naturfarbener oder schwarz lackierter Eiche, oder aus massivem naturfarbenem Nussbaum Canaletto; Lackierung mit Wachs-Endbehandlung. Gestell aus Stahl mit Federung auf elastischen Gurten. Polsterung aus Polyhurethan/wärmegebundener Polyesterfaser. Abnehmbarer Bezug aus Stoff oder Leder.

Butaca de orejas

Base en madera maciza de roble natural o teñido negro o en madera maciza de nogal Canaletto color natural; pintura con acabado de cera. Estructura de acero con suspensión sobre cintas elásticas. Acolchado de poliuretano/fibra poliéster termounida. Tapizado desenfundable en tejido o piel.

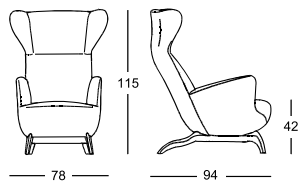

Rovere naturale/Natural oakwood/Rouvre naturel/Naturfarbene Eiche/Roble natural



Rovere tinto nero/Black varnished oak/Rouvre teinté noir/Schwarz-gebeizte Eiche/Roble teñido negro



Noce Canaletto/Canaletto walnut/Noyer Canaletto/Nussbaum Canaletto/Nogal Canaletto



Arom⁸⁷²



Design

Noé Duchaufour Lawrance

2014

Poltrona

Struttura in acciaio. Imbottitura in poliuretano/fibra poliestere termolegata con molleggio su nastri elastici. Rivestimento sfilabile in stoffa o pelle. La scocca esterna può essere rivestita anche in cuoio 95 in abbinamento a tessuto o pelle.

Armchair

Steel frame. Upholstery with polyurethane/heat bound polyester fibre with elastic strips suspension. Removable cover in fabric or leather. The exterior body can be covered with cowhide 95, combined with fabric or leather.

Fauteuil

Structure en acier. Rembourrage en polyuréthane/fibre polyester liée à chaud avec suspension sur sangles élastiques. Revêtement déhoussable en tissu ou en cuir. La coque extérieure peut également être revêtue en cuir sellier 95 en combinaison avec du tissu ou de cuir.

Sessel

Gestell aus Stahl. Polsterung aus Polyurethan/wärmegebundener Polyesterfaser mit Federung auf elastischen Gurten. Abnehmbarer Bezug aus Stoff oder Leder. Die Sitzschale kann außen mit Kernleder 95 in Kombination mit Stoff oder Leder bezogen werden.

Butaca

Estructura de acero. Acolchado de poliuretano/fibra poliéster termounida con suspensión sobre cintas elásticas. Tapizado desenfundable de tejido o de piel. El bastidor exterior puede ser tapizado en cuero 95 en combinación con tejido o piel.

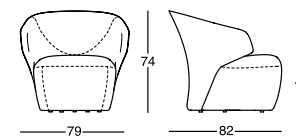

Calla 873



Design

Noé Duchaufour Lawrance

2010

Poltroncina

Base su ruote o fissa con piedini. Struttura in acciaio. Imbottitura in poliuretano/fibra poliestere termolegata con molleggio su nastri elastici. Rivestimento sfilabile in stoffa o in pelle. La scocca esterna può essere rivestita anche in cuoio 95 in abbinamento a tessuto o pelle. La poltroncina è disponibile in due differenti altezze da terra: alta 873/A con rotelle, bassa 873/B con piedini.

Small armchair

Base on castors or fixed with feet. Steel frame. Upholstery with polyurethane/heat bound polyester fibre with elastic strips suspension. Removable fabric or leather cover. The exterior body can be covered with cowhide 95, combined with fabric or leather. The armchair is available in two different heights above ground level: high 873/A with castors, low 873/B with feet.

Petit fauteuil

Base sur roulettes ou fixe avec pieds. Piètement en acier. Rembourrage de polyuréthane/fibre polyester liée à chaud avec suspension sur sangles élastiques. Revêtement déhoussable en tissu ou en cuir. La coque extérieure peut également être revêtue en cuir sellier 95 en combinaison avec du tissu ou de cuir. Le fauteuil est disponible en deux hauteurs du sol: haut 873/A avec roulettes, bas 873/B avec pieds.

Kleiner Sessel

Sockel auf Rollen oder fest mit Füßen. Gestell aus Stahl. Polsterung aus Polyurethan/wärmegebundener Polyesterfaser mit Federung auf elastischen Gurten. Abnehmbarer Bezug aus Stoff oder Leder. Die Sitzschale kann außen mit Kernleder 95 in Kombination mit Stoff oder Leder bezogen werden. Der kleine Sessel ist in zwei verschiedenen Höhen ab Boden erhältlich: hoch 873/A mit Rollen, niedrig 873/B mit Füßen.

Butaquita

Base sobre ruedas o fija con patas. Estructura de acero. Acolchado de poliuretano/fibra políester termounida con suspensión sobre cintas elásticas. Tapizado desenfundable de tejido o de piel. La butaquita está disponible en dos alturas diferentes: alto 873/A con ruedas, bajo 873/B con patas.

873/A

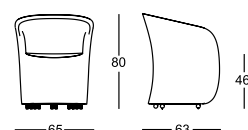

873/B

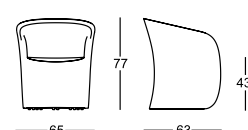

Campiello+ 880



Design

De Pas, D'Urbino, Lomazzi

1984-2022

Poltrona girevole

Schienale in multistrato di legno ricoperto in cuoio pigmentato 90 o cuoio 95. Non realizzabile in cuoio 95 colore bianco 0704 e cuoio pigmentato 90 bianco 0800. Sedile in poliuretano a quote differenziate/fiocchi di poliestere rigenerato e rigenerabile; poggiatesta e cuscino schienale in fiocchi di poliestere rigenerato e rigenerabile. Rivestimento sfilabile in stoffa. Solo il cuscino poggiatesta può essere richiesto in un colore diverso all'interno della stessa tipologia di tessuto.

Swivel armchair

Backrest in plywood covered with cowhide pigmentato 90 or with cowhide 95. Cannot be covered with cowhide 95 in the shade white 0704 and cowhide pigmentato 90, white 0800. Seat with graduated polyurethane/regenerated and regenerable polyester flakes; lumbar and back cushion in regenerated and regenerable polyester flakes. Removable fabric cover. Only the lumbar cushion can be requested in a distinct colour within the same fabric.

Fauteuil pivotant

Dossier en contreplaqué du bois recouvert en cuir sellier pigmentato 90 ou cuir sellier 95. Pas réalisable en cuir sellier 95 blanc 0704 ou en cuir sellier pigmentato 90, blanc 0800. Assise en polyuréthane à densité variable / flocons de polyester régénéré et régénérable; cale-reins et coussin de dossier en flocons de polyester régénéré et régénérable. Revêtement déhoussable en tissu. Le coussin cale-reins seulement peut être demandé dans le même type de tissu mais une couleur différente.

Drehbarer Sessel

Rücken aus Sperrholz, bezogen mit Kernleder pigmentato 90 oder mit Kernleder 95. Kann mit Kernleder 95 in weiß 0704 und mit Kernleder pigmentato 90, weiß 0800, nicht bezogen werden. Sitz aus Polyurethan in unterschiedlicher Dichte/ regenerierten und regenerierbaren Polyesterflocken; Nierenkissen und Rückenkissen aus regenerierten und regenerierbaren Polyesterflocken. Abnehmbarer Bezug aus Stoff. Nur das Nierenkissen kann innerhalb derselben Stoffart in einer anderen Farbe bestellt werden.

Butaca giratoria

Respaldo en madera contrachapada recubierta en cuero pigmentato 90 o cuero 95. No realizabile en cuero 95 color blanco 0704 y cuero pigmentato 90, blanco 0800. Asiento en poliuretano a densidades diferenciadas/ copos de poliéster regenerado y regenerable; cojín lumbar en copos de poliéster regenerado y regenerable. Tapizado desenfundable de tejido. Sobre pedido se puede hacer el cojín de respaldo en un color diferente dentro del mismo tipo de tejido.

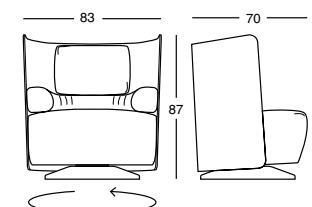

Derby⁸⁷⁵



Design

Noé Duchaufour Lawrance

2009 - 2010

Poltrona/bergère, pouf
Poltrona con base girevole in acciaio o fissa con piedini e scocca esterna in poliuretano rigido rivestita in cuoio 95. Imbottitura scocca interna e pouf in poliuretano/fibra poliester termolegata con molleggio su nastri elastici. Rivestimento sfilabile in stoffa o in pelle. Struttura pouf in acciaio.

Armchair/bergère, pouf
Armchair with steel base, swivel or fixed with feet and stiff polyurethane exterior body covered with cowhide 95. Upholstery of internal body and pouf in polyurethane/heat-bound polyester fibre with elastic strips suspension. Removable fabric or leather cover. Pouf steel frame.

Fauteuil/Bergère, pouf
Fauteuil avec base pivotante en acier ou fixée avec pieds et coque extérieure en polyuréthane rigide, revêtue en cuir sellier 95. Rembourrage de la coque intérieur et pouf en polyuréthane/fibre polyester liée à chaud avec suspension sur sangles élastiques. Revêtement déhoussable en tissu ou en cuir. Structure pouf en acier.

Sessel/Bergère, Hocker
Sessel mit Stahlsockel, drehbar oder fest mit Füßen und äußere Sitzschale aus steifem Polyurethan, mit Kernleder 95 bezogen. Innere Sitzschale und Hocker mit Polsterung aus Polyurethan/wärmegebundener Polyesterfaser mit Federung auf elastischen Gurten. Abnehmbarer Bezug aus Stoff oder Leder. Hocker-Gestell aus Stahl.

Sillón/bergère, puf
Sillón con base giratoria de acero o fija con pies y bastidor exterior de poliuretano tapizado de cuero 95. Acolchado del bastidor interior y del puf de poliuretano/fibra poliéster termounida con suspensión sobre cintas elásticas. Tapizado desenfundable de tejido o de piel. Estructura puf de acero.

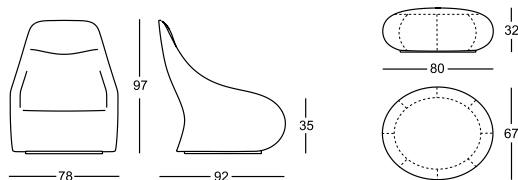

Galeotta⁸⁷⁷



Design

De Pas, D'Urbino, Lomazzi

1968-2023

Poltrona trasformabile
Struttura in poliuretano espanso a quote differenziate. Rivestimento sfilabile in stoffa.

Convertible armchair
Frame in graduated polyurethane foam. Removable fabric cover.

Fauteuil transformable
Structure en mousse de polyuréthane à densité variable. Revêtement déhoussable en tissu.

Umwandelbarer Sessel
Gestell aus Polyurethanschaum mit unterschiedlicher Dichte. Abnehmbarer Bezug aus Stoff.

Sillón convertible
Estructura en espuma de poliuretano a densidades diferenciadas. Tapizado desenfundable en tejido.

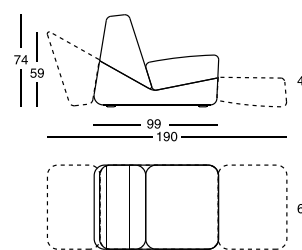



Design

Gabriele Mucchi

1935

Chaise longue

Struttura in acciaio cromato, o nichelsatinato colore naturale o nero, oppure verniciato arancione o nero. Molleggio su spirali di acciaio. Seduta regolabile su due posizioni. Imbottitura cuscino seduta e poggiatesta in poliuretano. Rivestimento cuscini e braccioli in pelle.

Lounge chair

Chromium-plated steel frame or with natural or black nickel-satin finish, or orange or black painted. Suspension on steel springs. Adjustable seat in two positions. Cushion and headrest upholstered in polyurethane. Leather-covered cushions and armrests.

Chaise longue

Structure en acier chromé, nickel satiné, dans les finitions naturelle ou noire, ou en acier verni orange ou noir. Suspension à spirales d'acier. Assise réglable en deux positions. Coussin et appuie-tête en polyuréthane. Revêtement coussins et accoudoirs en cuir.

Chaiselongue

Gestell aus verchromtem, orange oder schwarz-lackiertem Stahl, oder mit naturfarben- oder schwarz- vernickeltem und mattiertem Finish. Federung auf Stahlfedern. Sitzhöhe zweifach regulierbar. Kissen und Kopffrolle aus Polyurethan. Kissen- und Armlehnenbezug aus Leder.

Sillón

Estructura de acero cromado, o niquelado mate en los acabados natural o negro, o pintada de color naranja o negro. Muelles de espiral de acero. Asiento regulable en dos posiciones. Cojín y apoyacabeza acolchados de poliuretano. Tapizado cojines y apoyabrazos de piel.

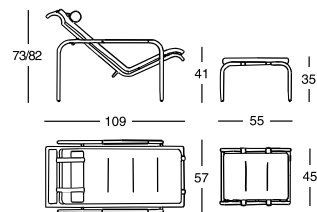

Struttura/Frame/Structure/ Gestell/Estructura



Omaggio a

Carlo Mollino

1953

Poltrona

Struttura in rovere naturale o tinto nero oppure in noce Canaletto colore naturale; verniciatura con finitura a cera. Parti metalliche in ottone nichelsatinato colore nero. Schienale regolabile su quattro posizioni. Imbottitura in poliuretano /fibra poliestere termolegata con molleggio su spirali d'acciaio. Rivestimento sfilabile in stoffa o in pelle.

Armchair

Frame in natural or black varnished oak, or in natural Canaletto walnut; wax-finished varnish. Black-nickel satin finished brass metal components. Four-position adjustable backrest. Upholstery in polyurethane/ heat-bound polyester fibre with suspension on steel springs. Removable fabric or leather cover.

Fauteuil

Structure en rouvre naturel ou teinté noir ou en noyer Canaletto, couleur naturelle; verni finition cirée. Quincaillerie en laiton nickel satiné couleur noire. Dossier réglable sur quatre positions. Rembourrage en polyuréthane/fibre de polyester liée à chaud avec suspension à spirales d'acier. Revêtement déhoussable en tissu ou en cuir.

Sessel

Gestell aus naturfarbener oder schwarz lackierter Eiche, oder aus naturfarbenem Nussbaum Canaletto; Lackierung mit Wachs-Endbehandlung. Metallteilen aus Messing mit schwarz-vernickelter und mattierter Ausführung. Rückenlehne in vier Positionen verstellbar. Polsterung aus Polyhurethan/ wärmegebundener Polyesterfaser mit Federung auf Stahlfedern. Abnehmbarer Bezug aus Stoff oder Leder.

Butaca

Estructura de roble natural o teñido negro o de nogal Canaletto color natural; pintura con acabado de cera. Herrajes de latón niquelado color mate negro. Respaldo regulable en cuatro posiciones. Acolchado de poliuretano/fibra de poliéster termounida con suspensión de espirales de acero. Tapizado desenfundable de tejido o de piel.

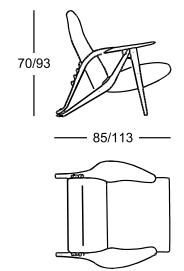

Rovere naturale/Natural oakwood/Rouvre naturel/ Naturfarbene Eiche/ Roble natural



Rovere tinto nero/Black varnished oak/ Rouvre teinté noir/Schwarz-gebeizte Eiche/ Roble teñido negro



Noce Canaletto/Canaletto walnut/Noyer Canaletto/ Nussbaum Canaletto/ Nogal Canaletto





Design

De Pas, D'Urbino, Lomazzi

1970

Poltrona

Struttura in legno multistrato con molleggio su nastri elastici e piedi in legno massello di faggio. Imbottitura amovibile in poliuretano schiumato con polioli a base vegetale. Assemblaggio privo di collanti. Rivestimento amovibile in stoffa.

Armchair

Multilayer wooden frame with elastic strip suspension and solid beech feet. Removable polyurethane foam upholstery with vegetable-based polyols. Glue-free assembly. Removable fabric cover.

Fauteuil

Structure en bois multicouche avec suspension sur sangles élastiques et pieds en hêtre massif. Rembourrage amovible en mousse de polyuréthane avec polyols d'origine végétale. Assemblage sans colle. Revêtement amovible en tissu.

Sessel

Sperrholzgestell mit Federung auf elastischen Gurten und Füßen aus massiver Buche. Abnehmbare Polyurethanschaum-Polsterung mit Polyolen auf pflanzlicher Basis. Leimfreie Montage. Abnehmbarer Bezug aus Stoff.

Butaca

Armazón de madera multicapa con suspensión sobre cintas elásticas y patas de haya maciza. Acolchado desenfundable de espuma de poliuretano con polioles vegetales. Montaje sin cola. Tapizado desenfundable en tejido.

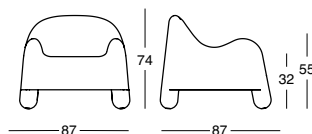

Design

Liisi Beckmann

1966

Poltrona

Struttura in poliuretano espanso a quote differenziate. Rivestimento sfilabile realizzabile solo nei tessuti Terso e Quantum.

Armchair

Graduated polyurethane foam frame. Removable cover only available in the fabrics Terso and Quantum.

Fauteuil

Structure en mousse de polyuréthane à densité variable. Revêtement déhoussable seulement dans les tissus Terso et Quantum.

Sessel

Gestell aus Polyurethanschaum in unterschiedlicher Dichte. Abnehmbarer Bezug nur mit den Stoffen Terso und Quantum.

Butaca

Estructura en espuma de poliuretano a densidades diferenciadas. Tapizado desenfundable solo en los tejidos Terso y Quantum.

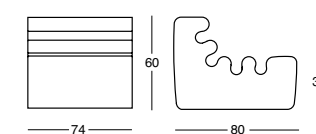



Design

Ludovica+Roberto Palomba

2013

Poltrona

Base girevole in acciaio verniciato, colore nero o grafite. Struttura in acciaio. Imbottitura in poliuretano/ fibra poliestere termolegata. Rivestimento sfilabile in stoffa o in pelle.

Armchair

Revolving base in varnished steel, colours: black or graphite. Steel frame. Upholstery in polyurethane/ heat-bound polyester fibre. Removable fabric or leather cover.

Fauteuil

Piètement pivotant en acier verni, couleur noire ou graphite. Structure en acier. Rembourrage de polyuréthane/fibre polyester liée à chaud. Revêtement déhoussable en tissu ou en cuir.

Sessel

Drehbarer Stahlsockel, graphitfarben oder schwarz lackiert. Stahlgestell. Polsterung aus Polyurethan/ wärmegebundener Polyesterfaser. Abnehmbarer Bezug aus Stoff oder Leder.

Butaca

Base giratoria de acero barnizado, color negro o grafito. Estructura de acero. Acolchado de poliuretano/ fibra poliéster termounida. Tapizado desenfundable de tejido o de piel.

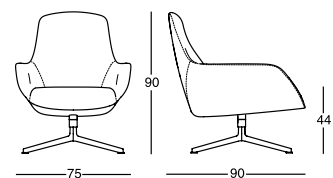

Base/Base/Piètement/Sockel/Base



Design

Ludovica+Roberto Palomba

2013

Poltrona/bergère. Pouf

Base girevole in acciaio verniciato, colore nero o grafite. Struttura in acciaio. Imbottitura in poliuretano/ fibra poliestere termolegata. Rivestimento sfilabile in stoffa o in pelle

Armchair/bergère. Pouf

Revolving base in varnished steel, colours: black or graphite. Steel frame. Upholstery in polyurethane/ heat-bound polyester fibre. Removable fabric or leather cover.

Fauteuil/bergère. Pouf

Piètement pivotant en acier verni, couleur noire ou graphite. Structure en acier. Rembourrage de polyuréthane/fibre polyester liée à chaud. Revêtement déhoussable en tissu ou en cuir.

Sessel/bergère. Hocker

Drehbarer Stahlsockel, graphitfarben oder schwarz lackiert. Stahlgestell. Polsterung aus Polyurethan/ wärmegebundener Polyesterfaser. Abnehmbarer Bezug aus Stoff oder Leder.

Butaca/bergère. Púf

Base giratoria de acero barnizado, color negro o grafito. Estructura de acero. Acolchado de poliuretano/ fibra poliéster termounida. Tapizado desenfundable de tejido o de piel.

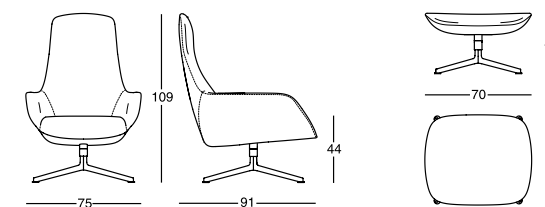

Base/Base/Piètement/Sockel/Base



Lama ⁹²¹



Design

Ludovica+Roberto Palomba

2006

Chaise longue
Struttura in acciaio verniciato, colore grafite. Imbottitura in poliuretano con molleggio su nastri elastici. Rivestimento sfilabile in stoffa o pelle, o non sfilabile in cuoio.

Lounge chair
Graphite varnished steel frame. Polyurethane upholstery with elastic strips suspension. Removable cover in fabric or leather, or non-removable in cowhide.

Chaise longue
Structure en acier verni, couleur graphite. Rembourrage de polyuréthane avec suspensions sur sangles élastiques. Revêtement déhoussable en tissu ou cuir, ou pas déhoussable en cuir sellier.

Chaiselongue
Lackiertes Stahlgestell, Graphitfarben. Polsterung aus Polyurethan auf elastischen Gurten. Abnehmbarer Bezug aus Stoff oder Leder, oder nicht abnehmbar aus Kernleder.

Sillón
Estructura de acero pintado color grafito. Acolchado de poliuretano sobre cintas elásticas. Tapizado desenfundable en tejido o piel, o non desenfundable en cuero.

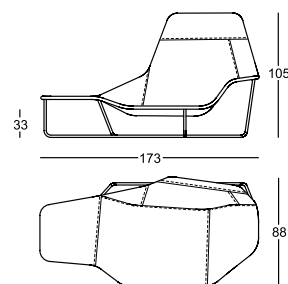

Maggiolina ⁹⁰⁰

NEW FINISHES



Design

Marco Zanuso

1947

Chaise longue
Struttura in acciaio inox lucidato, o nichelsatinato colore naturale o nero, oppure verniciato arancione o nero. Scocca in cuoio pigmentato 90. Imbottitura cuscino schienale in piuma d'oca. Imbottitura cuscino seduta in poliuretano/Dacron Du Pont. Rivestimento, cuscini e braccioli in stoffa, Ecofire o pelle.

Lounge chair
Polished, orange- or black painted steel tubular frame, or with natural or black nickel-satin finish. Sling in cowhide pigmentato 90. Back cushion in new goose feathers. Seat cushion upholstered in polyurethane/Dacron Du Pont. Cushions and armrests covered with fabric, Ecofire or leather.

Chaise longue
Structure en acier inox poli, nickel satiné dans les finitions naturelle ou noire, ou verni couleur orange ou noire. Support en cuir sellier pigmentato 90. Coussin dossier en plume d'oie. Coussin assise en polyuréthane/Dacron Du Pont. Revêtement, coussins et accoudoirs en tissu, Ecofire ou cuir.

Chaiselongue
Gestell aus poliertem, orange- oder schwarz lackiertem Inox-Stahl oder mit naturfarben- oder schwarz- vernickeltem und mattiertem Finish. Tragschale aus Kernleder pigmentato 90. Rückenkissen gefüllt mit reinen Gänsefedern. Sitzkissen aus Polyurethan/Dacron Du Pont. Kissen- und Armlehnen-Bezug aus Stoff, Ecofire oder Leder.

Sillón
Estructura de acero inox pulido o niquelado mate en los acabados natural o negro, o pintado de color naranja o negro. Soporte para los cojines de cuero pigmentato 90. Cojín respaldo acolchado de plumas de ganso. Cojín asiento acolchado de poliuretano/Dacron Du Pont. Tapizado cojines y apoyabrazos de tejido, Ecofire o piel.

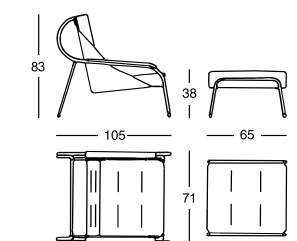

Struttura/Frame/Structure/ Gestell/Estructura





Design

Bernard Marstaller

1917

Poltroncina con schienale basculante
Struttura in faggio, colore naturale. Schienale inclinabile. Rivestimento sfilabile in Telastrong o in cuoio.

Armchair with tilting backrest
Natural beech frame. Tilting back. Removable cover in Telastrong or cowhide.

Petit fauteuil avec dossier inclinable
Structure en hêtre, couleur naturelle. Dossier inclinable. Revêtement déhoussable en Telastrong ou en cuir sellier.

Armlehnstuhl mit verstellbarer Rückenlehne
Gestell aus Buche, naturfarben. Schräg verstellbare Rückenlehne. Abnehmbarer Bezug aus Telastrong oder aus Kernleder.

Butaquita con respaldo basculante
Estructura de haya, color natural. Respaldo abatible. Tapizado desenfundable en Telastrong o en cuero.

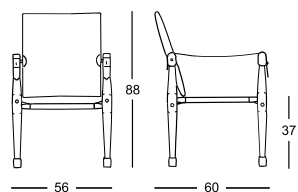

Design

Lanzavecchia + Wai

2023

Poltrona
Struttura in acciaio verniciato colore amaranto, espresso, grafite o nero. Imbottitura sedile in poliuretano a quote differenziate/Dacron Du Pont, imbottitura schienale in poliuretano schiumato autoestinguente. Rivestimento sfilabile in stoffa o in pelle.

Armchair
Steel frame varnished amaranth, espresso, graphite or black. Seat upholstered in graduated polyurethane/Dacron Du Pont; backrest upholstered with self-extinguishing polyurethane foam. Removable cover in fabric or leather.

Fauteuil
Structure en acier verni rouge amarante, espresso, graphite ou noir. Assise rembourrée en polyuréthane à densité variable/Dacron Du Pont, dossier rembourré en mousse de polyuréthane autoextinguible. Revêtement déhoussable en tissu ou en cuir.

Sessel
Gestell aus Amaranthrot, Espresso, Graphitfarben oder schwarz lackiertem Stahl. Sitz -Polsterung aus Polyurethan mit unterschiedlicher Dichte/ Dacron Du Pont. Rückenlehne mit selbstlöschendem Polyurethanschaum gepolstert. Abnehmbarer Bezug aus Stoff oder Leder.

Butaca
Estructura de acero pintado en los colores granate, espresso, grafito o negro. Acolchado del asiento de poliuretano a densidades diferenciadas/Dacron Du Pont; acolchado del respaldo de espuma de poliuretano autoextintivo. Tapizado desenfundable de tejido o piel.

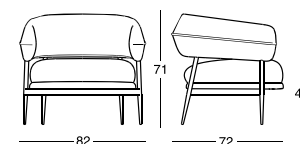

Struttura/Frame/Structure/Gestell/
Estructura





Design

Constance Guisset

2019

Poltrona

Gambe in legno massello di acero laccato nero. Struttura in acciaio. Imbottitura in poliuretano/fibra poliester termolegata. Rivestimento sfilabile in stoffa o pelle.

Armchair

Legs in black laquered solid maple wood. Steel frame. Upholstery with self-extinguishing polyurethane foam/heat-bound polyester fibre. Removable cover in fabric or leather.

Fauteuil

Pieds en bois massif d'érable laqué noir. Structure en acier. Rembourrage en mousse de polyuréthane autoextinguible/fibre de polyester liée à chaud. Revêtement déhoussable en tissu ou en cuir.

Sessel

Beine aus schwarz lackiertem massiven Ahornholz. Stahl-Gestell. Polsterung aus selbstlöschendem Polyurethan-Schaum/wärmegebundener Polyesterfaser. Abnehmbarer Bezug aus Stoff oder Leder.

Butaca

Patas de madera maciza de arce lacada negro. Estructura de acero. Acolchado de espuma de poliuretano autoextintivo/fibra poliéster termounida. Tapizado desenfundable de tejido o de piel.

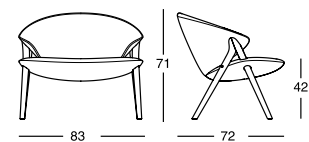

Sacco Small ²⁷⁸ Sacco Medium ²⁷⁹ Sacco ²⁸⁰



Design

Gatti, Paolini, Teodoro

1968

IN/OUT

Poltrone anatomiche

Involucro contenente palline di polistirolo espanso ad alta resistenza. Rivestimento in Vip (anche per esterni, antibatterico con trattamento Silverguard® e antimacchia con trattamento Permablock 3®) e pelle.

Anatomical easy chairs

Envelope containing highly resistant expanded polystyrene pellets. Cover in: Vip (also for outdoor, antibacterial with Silverguard® and stain-proof with Permablock 3® treatment) and leather.

Fauteuils anatomiques

Housse contenant de petites billes de polystyrène à grande résistance. Revêtement en: Vip (aussi pour extérieurs, antibactérien avec traitement Silverguard® et antitache avec traitement Permablock 3®) et cuir.

Anatomische Sessel

Hülle mit aufgeschäumten Polystyrol-Kügelchen gefüllt, widerstandsfähig. Bezug aus: Vip (auch fürs Freie, anti-bakteriell mit Behandlung Silverguard® und Fleckenschutz mit Behandlung Permablock 3®) und Leder.

Butacas anatómicas

Bolsa rellena de bolitas de poliestirol expando de alta resistencia. Tapizado en: Vip (tambien para exteriores, antibacteriano con tratamiento Silverguard® y antimancha con tratamiento Permablock 3®) y piel.

278

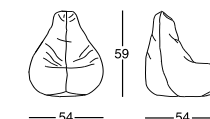

279

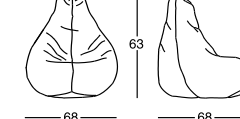

280

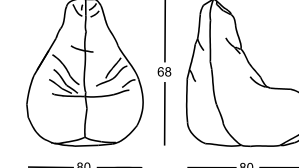

Rivestimento/Cover/Revêtement/Bezug/Tapizado

VIP

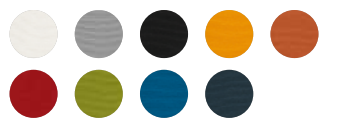

Sant'Elia ⁸⁵⁰



Design

Giuseppe Terragni

1936

Poltroncina

Struttura in acciaio inox 18/8. Imbottitura in poliuretano. Rivestimento in pelle.

Armchair

18/8 stainless steel frame. Polyurethane upholstery. Leather cover.

Petit fauteuil

Structure en acier inox 18/8. Rembourrage en polyuréthane. Revêtement en cuir.

Armlehnstuhl

Gestell aus Inox-Stahl 18/8. Polsterung aus Polyurethan. Bezug aus Leder.

Butaquita

Estructura de acero inox 18/8. Acolchado de poliuretano. Tapizado en piel.

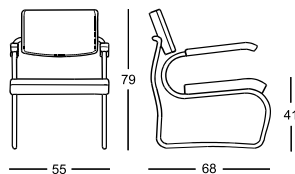

Susanna ⁸⁵²



Design

Gabriele Mucchi

1983

Poltroncina

Struttura portante in tubo di acciaio cromato, o nichelsatinato colore naturale o nero, oppure verniciato nero. Telaio porta-cuscini in acciaio verniciato nero, regolabile su due posizioni. Imbottitura cuscini in poliuretano/ fibra poliestere termolegata. Rivestimento cuscini sfilabile in stoffa o pelle. Nella versione con cuscini rivestiti in tessuto, i braccioli sono in pelle 95.

Armchair

Carrying frame in chromium-plated, or in natural or black nickel-satin finished, or black painted tubular steel. Adjustable two-position cushion support in black painted steel. Cushions upholstery in polyurethane/ heat-bound polyester fibre. Removable cushions cover in fabric or leather. The model with fabric covered cushions features the armrests covered with leather 95.

Petit fauteuil

Structure portante en tube d'acier chromé, ou nickel satiné, dans les finitions naturelle ou noire, ou verni noir. Châssis porte-coussins en acier verni noir, réglable sur deux positions. Rembourrage coussins en polyuréthane/fibre polyester liée à chaud. Revêtement coussins déhoussable en tissu ou cuir. Dans la version avec les coussins en tissu, les accoudoirs sont en cuir 95.

Armlehnstuhl

Gestell aus verchromtem oder schwarz-lackiertem Stahlrohr, oder mit naturfarben-oder schwarz-vernicheltem und mattiertem Finish. Kissenträger-Rahmen aus schwarz lackiertem Stahl, in zwei Positionen verstellbar. Polsterung der Kissen aus Polyurethan/wärmegebundener Polyesterfaser. Abnehmbarer Kissen-Bezug aus Stoff oder Leder. Für die Version mit Stoff-bezogenen Kissen, sind die Armlehnen mit Leder 95.

Butaquita

Estructura tubular de acero cromado, o niquelado mate en los acabados natural o negro, o lacado negro. Bastidor porta-cojines de acero pintado de negro, regulable en dos posiciones. Acolchado de los cojines de poliuretano/fibra poliéster termounida. Tapizado desenfundable de los cojines de tejido o de piel. Por el modelo con cojines tapizados de tejido, los apoyabrazos están tapizados de piel 95.

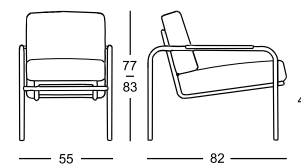

Struttura/Frame/Structure/Gestell/Estructura



Tavolini, Comodini
Small Tables,
Nightstands
Petites tables, Tables
de *chevet*
Couchtische,
Nachttische
Mesitas, Mesitas
de noche

Arabesco CM ⁶⁹⁷



Omaggio a

Carlo Mollino

1949

Tavolino

Struttura in multistrati curvato, in rovere naturale o tinto nero; verniciatura con finitura a cera. La struttura è fissata al piano tramite bussole passanti. Piano superiore in cristallo temperato, piano inferiore in cristallo temperato, entrambi rispettivamente in cristallo extra-chiaro per la versione in rovere naturale o in cristallo fumè grigio per la versione in rovere tinto nero.

Small table

Bent plywood frame in natural or black varnished oak; wax-finished varnish. The frame is attached to the top with an internally threaded screw. Top shelf in tempered plate glass; bottom shelf in tempered plate glass, both either extra-clear, matching the frames in natural oak or in smoky grey plate glass, matching the black varnished oak frame.

Petite table

Structure en contreplaqué courbé, plaqué en rouvre naturel ou teinté noir; verni finition cirée. La structure est fixée au plateau avec des traversées. Plateau supérieur en verre trempé. Tablette inférieure en verre trempé, les deux respectivement en verre extra-clair pour la version en rouvre naturel ou en verre gris fumé pour la version en rouvre teinté noir.

Couchtisch

Gestell aus gebogenem Schichtholz, mit naturfarbener oder schwarz lackierter Eiche furniert; Lackierung mit Wachs-Endbehandlung. Das Gestell ist mittels Durchführungsbuchsen am Gestell verbunden. Obere Platte aus gehärtetem Kristallglas; untere Platte aus gehärtetem Kristallglas, beide entweder extra-klar für die Version aus naturfarbener Eiche oder grau rauchfarben für die Version aus schwarz lackierter Eiche.

Mesita

Estructura en madera contrachapada curvada, aplacada en roble natural o teñido negro; pintura con acabado de cera. La estructura se fija al sobre con brújulas que pasan a través. Superficie superior en cristal templado; superficie inferior en cristal templado, ambos respectivamente en cristal extra-claro para la versión de roble natural o en cristal gris humo para la versión de roble teñido negro.

Struttura/Frame/Structure/Gestell/Estructura

Rovere naturale/
Natural
oakwood/
Rouvre naturel/
Naturfarbene
Eiche/Roble
natural



Rovere tinto nero/
Black varnished
oak/Rouvre teinté
noir/Schwarz-
gebeizte Eiche/
Roble teñido
negro



Piano/Top/Plateau/Platte/Sobre

Cristallo extra-
chiaro/Extra-clear
plate glass/Verre
extra-clair/Extra-
klare Kristallglas/
Cristal extra-claro



Cristallo fumé
grigio/Smoky
grey plate glass/
Verre gris fumé/
Rauchfarbenes
Kristallglas/Cristal
gris humo

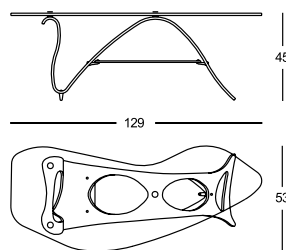

Basello ⁶³⁸

NEW FINISHES



Design

Achille Castiglioni

1987

Tavolino a doppia altezza con ripiani rotanti

Struttura in medium density fiberboard, verniciatura gofrata antigraffio nei colori talco, canapa, amaranto, espresso o nero. Snodo in acciaio verniciato nero nelle versioni canapa, amaranto, espresso o nera, oppure talco nella versione talco.

Double height small table with rotating shelves

Frame in medium density fiberboard finished with scratch resistant embossing in the shades talc, hemp, amaranth, espresso or black. Steel articulated joint in the shade black for the models hemp, amaranth, espresso, black or in the shade talc for the talc model.

Petite table à deux hauteurs à étagères pivotantes

Structure en medium density fiberboard, vernie antirayures dans les couleurs talc, chanvre, rouge amarante, espresso ou noire. Articulation en acier verni noir dans les versions chanvre, rouge amarante, espresso, noir, ou verni talc pour la version talc.

Zweiteiliger verstellbarer mit Drehregalen

Gestell aus Medium Density Fiberboard mit Anti-Kratzer-Lackierung, in den Farben Talcum, Hanf, Amarantröt, Espresso oder schwarz. Verbindungsstück aus schwarz-lackiertem Stahl für die Modelle in den Farben Hanf, Amarantröt, Espresso, schwarz, oder Talcum-lackiert für die Talcum-Version.

Mesita de doble altura con estantes giratorios

Estructura en medium density fiberboard, laca en relieve anti-rasguño en los colores talco, cañamo, granate, espresso o negro. Articulación de acero pintado negro por las versiones en cañamo, granate, espresso, negro o talco por la versión en talco.

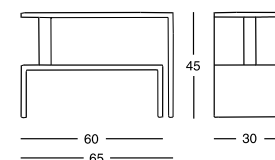

Verniciatura gofrata/Embossed paint/Vernissage gaufré/Gaufrierte Lackierung/Lacadura anti-rasguño



Snodo/Articulated joint/Articulacion/Verbindungsstück/Articulación





Design

Alexander Taylor Zanotta - E&Y Co-Edition

2006

Tavolino

Struttura in multistrati curvato, impiallacciato in rovere naturale o tinto talco o nero. Piano in cristallo temperato.

Small table

Bent plywood frame, veneered with natural, talc or black painted oak. Top in tempered plate glass.

Petite table

Structure en contreplaqué courbé, plaqué en rouvre, couleur naturelle ou teinté talc ou noir. Plateau en cristal trempé.

Beistelltisch

Untergestell aus gebogenem Sperrholz, eichenfurniert, naturfarben, Talkum oder schwarz lackiert. Platte aus gehärtetem Kristallglas.

Mesita

Estructura con panel multistrato curvado, contrachapado en roble natural, teñido talco o negro. Sobre de cristal templado.

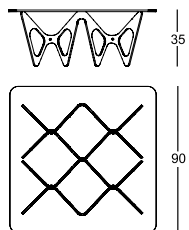

Omaggio a

Carlo Mollino

1938

Contenitore di servizio

Struttura e cassetto in legno verniciato nei colori talco e nero. Pianetto d'appoggio in cristallo nei medesimi colori. Prevede il fissaggio a parete.

Service storage unit

Frame and drawer in painted wood, in the shades talc and black. Plate glass top in the same colours. It must be fastened to wall.

Petit meuble d'appoint

Structure et tiroir en bois peint couleur talc et noir. Tablette d'appui en verre dans les mêmes couleurs. Prevede il fissaggio a parete.

Service-Behälter

Gestell und Schublade aus lackiertem Holz, in den Farben Talkum und schwarz. Platte aus Kristallglas in den gleichen Farben. Für die Wandmontage vorgesehen.

Mueble de apoyo

Estructura y cajón de madera lacada en los colores talco y negro. Superficie de apoyo en cristal en los mismos colores. Prevede il fissaggio a parete.

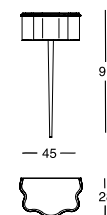



Design

Achille Castiglioni

1978

Tavolino pieghevole

Struttura e piano in acciaio verniciato talco, amaranto, verde prato o nero. Giunto scorrevole in ABS. E' dotato di un gancio per appenderlo a parete.

Folding table

Steel frame and top. Colours: talc, amaranth, grass green or black. ABS sliding joint. It is equipped with a hook for hanging.

Petite table pliante

Structure et plateau en acier, dans les couleurs talc, rouge amarante, vert pré ou noire. Joint coulissant en ABS. Il est équipé d'un crochet pour l'accrocher au mur.

Klapptisch

Gestell und Platte aus Stahl in den Farben Talkum, Amarantröt, grasgrün, oder schwarz. Verschiebbares Gelenk aus ABS. Er ist mit einem Haken zum Aufhängen an der Wand ausgestattet.

Mesita plegable

Estructura y sobre de acero, en los colores: talco, granate, verde prado o negro. Anilla corredera en ABS. Esta equipado de un gancho para colgarlo a la pared.

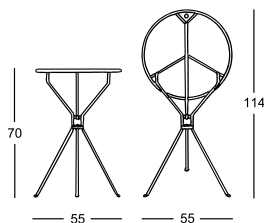

Struttura/Frame/Structure/Gestell/Estructura



Design

Sebastian Herkner

2019

Tavolino

Gambe in vetro soffiato a tre strati nei colori fumè o ambra. Piani in lamiera di acciaio nichelsatinato colore naturale o nero.

Small table

Three-layered blown glass legs in the shades smoky grey or amber. Steel sheet top with natural or black nickel-satin finish.

Petite table

Pieds en verre soufflé à trois couches dans les couleurs gris-fumé ou ambre. Plateau en tôle d'acier dans les finitions nickel satiné naturel ou noir.

Beistelltisch

Beine aus dreischicht-geblasenem Glas in den Farben rauchgrau oder Bernstein. Platten aus Stahlblech mit naturfarben oder schwarz vernickeltem Finish.

Mesita

Patas de vidrio soplado de tres capas en color gris ahumado o ámbar. Sobre de chapa de acero en los acabados níquel satinado natural o negro.

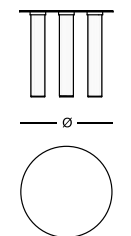

Dimensioni/Sizes/Dimensions/Abmessungen/Medidas

Ø 48 H 44 cm
Ø 68 H 34 cm

Gambe/Legs/Pieds/Beine/Patas





Design

Anna Deplano

1997-1999

Tavolino con rotelle

Struttura in acciaio verniciato, colore alluminio. Pianetti in laminato plastico stratificato, colore bianco.

Castor-mounted table

Aluminium-painted steel frame. Shelves in layered plastic laminate in white.

Petite table avec roulettes

Structure en acier verni, couleur aluminium. Plateaux en laminé plastique stratifié, couleur blanc.

Tischchen mit Rollen

Gestell aus alufarben lackiertem Stahl. Platten aus massivem weißen Plastiklaminat.

Mesita con ruedas

Estructura de acero pintado de color aluminio. Repisas de laminado plástico estratificado, de color blanco.

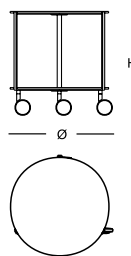

Dimensioni/Sizes/Dimensions/Abmessungen/Medidas

Ø 50 H 53,5 cm
Ø 75 H 37 cm
Ø 110 H 37 cm



Design

Garcia Cumini

2019

Tavolini

Struttura in acciaio verniciato colore nero. Piani in marmo Calacatta grigio, in marmo rosso Lepanto o in marmo Sahara Noir con verniciatura protettiva antimacchia, in poliester trasparente opaco.

Small tables

Black varnished steel frame. Tops available either in grey Calacatta marble, in red Lepanto marble or in Sahara Noir marble with stain-resistant protective varnish, in clear matt polyester.

Petites tables

Structure en acier verni noir. Plateaux en marbre Calacatta gris, en marbre rouge Lepanto ou en marbre Sahara Noir avec peinture de protection anti-taches en polyester transparent opaque.

Couchtische

Gestell aus schwarz lackiertem Stahl. Platten aus graufarbenem Calacatta Marmor, oder aus rotem Lepanto Marmor oder aus Sahara Noir Marmor mit Fleckenschutz Lackierung aus klarem mattem Polyester.

Mesitas

Estructura en acero pintado negro. Sobres de mármol Calacatta gris, de mármol Sahara Noir con laca de protección antimancha en poliéster opaco transparente.

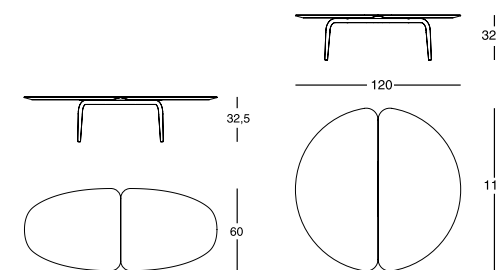

681

682

Dimensioni/Sizes/Dimensions/Abmessungen/Medidas

140x60 cm
200x60 cm
120x118 cm

Piano/Top/Plateau/Platte/Sobre

Marmo Calacatta/ Calacatta marble/ Marbre Calacatta/ Calacatta Marmor/ Mármol Calacatta
Marmo Lepanto/ Lepanto marble/ Marbre Lepanto/ Lepanto Marmor/ Mármol Lepanto
Marmo Sahara Noir/ Sahara Noir marble/ Marbre Sahara Noir/ Sahara Noir Marmor/ Mármol Sahara Noir





Design

Federica Capitani

2016

Tavolini

Struttura in acciaio verniciato colore talco o nero. Piani in marmo bianco di Carrara, in marmo nero Marquinia o in marmo Emperador, con verniciatura protettiva antimacchia, in poliestere trasparente opaco.

Small tables

Steel frame painted in the shades talc or black. Tops available either in white Carrara marble, in black Marquinia marble or in Emperador marble, with stain resistant protective varnish, in clear matt polyester.

Petites tables

Structure en acier verni talc ou noir. Plateaux en marbre blanc de Carrare, en marbre noir Marquinia ou en marbre Emperador, avec vernis de protection anti-taches de polyester transparent mat.

Beistelltische

Gestell aus Talkum oder schwarz lackiertem Stahl. Platten aus weißem Carrara Marmor, oder aus schwarzem Marquinia Marmor oder aus Emperador Marmor, mit Fleckenschutz Lackierung aus klarem mattem Polyester.

Mesitas

Estructura de acero pintado talco o negro. Sobres en mármol blanco de Carrara, en mármol negro Marquinia o en mármol Emperador, con laca de protección anti mancha, en poliéster mate transparente.

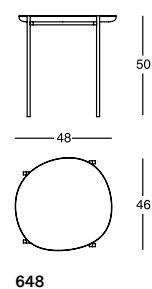

648

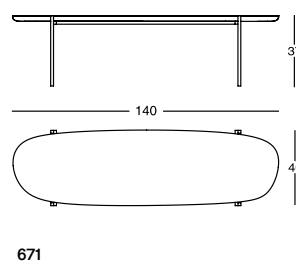

671

Struttura/Frame/Structure/
Gestell/Estructura



Piano/Top/Plateau/Platte/Sobre

Marmo Marquinia/
Marquinia
marble/Marbre
Marquinia/
Marquinia
Marmor/Mármol
Marquinia

Marmo
Emperador/
Emperador
marble/Marbre
Emperador/
Emperador
Marmor/Mármol
Emperador

Marmo di Carrara/
Carrara marble/
Marbre de
Carrare/Carrara
Marmor/Mármol
de Carrara



Design

Emaf Progetti

2005

Comodino con cassetto

Struttura in acciaio verniciato colore grafite. Maniglia in alluminio verniciato colore grafite. Cassetto in medium density fiberboard impiallacciato in rovere naturale, tinto grigio o talco.

Night table with drawer

Graphite painted steel frame. Handle in graphite painted aluminium. Drawer in medium density fiberboard veneered with natural oak or varnished grey or talc.

Table de chevet avec tiroir

Structure en acier verni couleur graphite. Poignée en aluminium verni couleur graphite. Tiroir en medium density fiberboard, contreplaqué en rovere naturel, teinté gris ou talc.

Nachttisch mit Schublade

Gestell aus Graphit lackiertem Stahl. Griff aus Graphit lackiertem Aluminium. Schublade aus medium density fiberboard mit Eichenfurnier, naturfarben, grau oder Talkum gebeizt.

Mesita de noche con cajón

Estructura de acero pintado grafito. Manecilla de aluminio pintado color grafito. Cajón de medium density fiberboard enchapado de roble natural, teñido gris o talco.

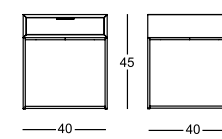

Cassetto/Drawer/Tiroir /Schublade/Cajón

Rovere tinto talco/
Talc varnished
oak/Rouvre
teinté talc/Talkum
gebeizte Eiche/
Roble teñido talco

Rovere tinto
grigio/Grey
varnished oak/
Rouvre teinté gris/
Grau gebeizte
Eiche/Roble
teñido gris

Rovere naturale/
Natural oakwood/
Rouvre naturel/
Naturfarbene
Eiche/Roble
natural



Quaderna Coffee Table ⁶⁵⁶

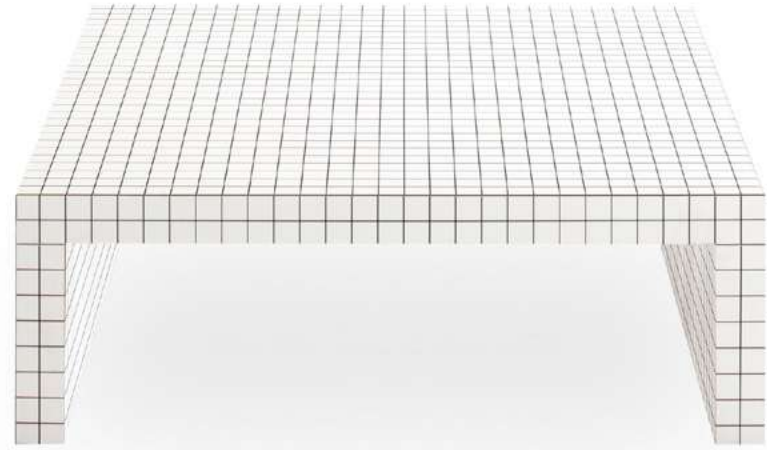

Design Superstudio

1969-1972

Tavolino

Struttura in legno tamburato placcato laminato Print, colore bianco, a stampa digitale a quadretti con interasse di 3 cm.

Coffee table

Honeycomb core structure coated with white Print laminate, digitally printed with black squares at 3 cm spacing.

Petite table

Structure en panneau alvéolaire plaqué en laminé Print, couleur blanche, imprimé en digital à carrés noirs avec entraxe de 3 cm.

Beistelltisch

Gestell aus Sperrholz mit weißem Print Laminat belegt. Digitaldruck mit kariertem Muster, Linienabstand 3 cm.

Mesita

Estructura de madera aplacada con laminado Print, color blanco, a impresión digital en cuadrillos negros de 3 cm.

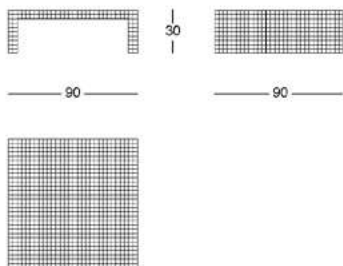

Quaderna Small Table ⁷¹⁰

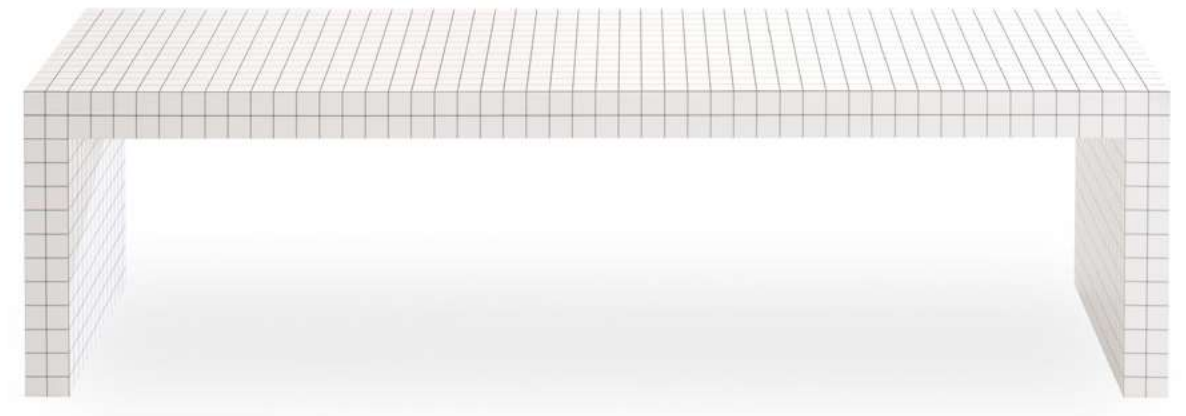

Design Superstudio

1969-1972

Tavolino

Struttura in legno tamburato placcato laminato Print, colore bianco, a stampa digitale a quadretti con interasse di 3 cm.

Small table

Honeycomb core structure coated with white Print laminate, digitally printed with black squares at 3 cm spacing.

Petite table

Structure en panneau alvéolaire plaqué en laminé Print, couleur blanche, imprimé en digital à carrés noirs avec entraxe de 3 cm.

Beistelltisch

Gestell aus Sperrholz mit weißem Print Laminat belegt. Digitaldruck mit kariertem Muster, Linienabstand 3 cm.

Mesita

Estructura de madera aplacada con laminado Print, color blanco, a impresión digital en cuadrillos negros de 3 cm.

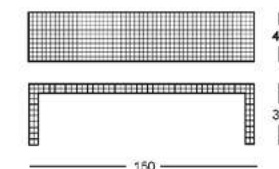

Servomuto ³⁶⁰

NEW FINISHES



Design

Achille Castiglioni della serie Servi di Achille & Pier Giacomo Castiglioni 1974

Tavolino

Base in polipropilene e asta in acciaio verniciato colore talco o nero. Pianetto in laminato plastico stratificato, colore bianco/nero, reversibile.

Small table

Base in polypropylene and steel rod painted, colour talc or black. Top in reversible black/white plastic laminate.

Petite table

Base en polypropylène et tige en acier peint en couleur talc ou noir. Plateau en laminé plastique stratifié, couleur blanc/noir, réversible.

Beistelltisch

Fuß aus Polypropylen und Stange aus lackiertem Stahl, Farbe Talkum oder schwarz. Tischplatte aus massivem Plastiklaminat, in den Farben weiß/schwarz, umkehrbar.

Mesita

Base de polipropileno y soporte de acero pintado, color talco o negro. Repisa de laminado plástico estratificado, en los colores blanco/negro, reversible.

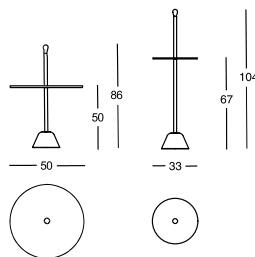

Struttura/Frame/Structure/Gestell/Estructura



Pianetti/Shelves/Plateaux/Platten/Repisas



Sgabillo ⁶⁵⁰



Design

Max Bill 1950

Sgabello

Struttura in multistrati di betulla verniciata, colore naturale, o in medium density fiberboard, verniciatura gofrata antigraffio, colore nero.

Stool

Structure in natural varnished, layered birch or in black lacquered medium density fiberboard finished with scratch-resistant embossing.

Tabouret

Structure en contreplaqué de bouleau verni, couleur naturelle ou en medium density fiberboard, vernissage gaufré antirayures, couleur noire.

Hocker

Gestell aus Birkensperrholz, naturfarben oder aus Medium Density Fiberboard, gaufrierte Anti-Kratzer-Lackierung, schwarz.

Taburete

Estructura de madera chapada de abedul, barnizada de color natural o de medium density fiberboard, laca en relieve anti-rasguño, color negro.

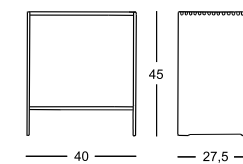

Struttura/Frame/Structure/Gestell/Estructura





Design

Philippe Malouin

2024

IN/OUT

Tavolino

Struttura in gres fine porcellanato antigelivo per esterni. Smaltatura lucida nei colori: talco, canapa, caramello, arancione, espresso.

Small table

Freeze-resistant frame in fine porcelainized grès for outdoor use. Polished enamelling in the colours: talc, hemp, caramel, orange, espresso.

Petite table

Structure en grès fin émaillé résistante au gel pour externes. Émaillage poli dans les couleurs: talc, chanvre, caramel, orange, espresso.

Beistelltisch

Gestell aus frostfestem und wetterbeständigem Feinsteinzeug. Polierte Glasur in den Farben: Talkum, Hanf, Karamell, Orange, Espresso.

Mesita

Estructura de gres fino porcelánico antihielo para uso exterior. Esmaltado brillante en los colores: talco, cáñamo, caramelo, naranja, espresso.

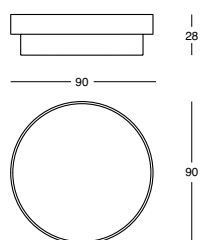

Struttura/Frame/Structure/Gestell/Estructura



Design

Gabriele Rosa

2017

Comodino con cassetto

Struttura e piano in acciaio verniciato colore talco, nero o grafite. Piano e vano portaoggetti in cuoio pigmentato 90. Il vano è accessibile mediante apertura a ribalta.

Nightstand with drawer

Top and frame in talc, black or graphite painted steel. Top and storage space in cowhide pigmentato 90. The storage is accessed by a dropleaf opening.

Table de chevet avec tiroir

Structure et plateau en acier verni couleur talc, noire ou graphite. Plateau et élément porte-objets en cuir sellier pigmentato 90. L'élément est accessible par une ouverture basculante.

Nachtisch mit Schublade

Gestell und Platte aus Talkum-, schwarz- oder graphitfarben- lackiertem Stahl. Platte und Ablagefach aus Kernleder pigmentato 90. Das Ablagefach ist mit Kippöffnung versehen.

Mesita de noche con cajón

Estructura y sobre de acero pintado de color talco, negro o grafito. Sobre y compartimento portaobjetos de cuero pigmentato 90. Se puede acceder al compartimento mediante apertura abatible.

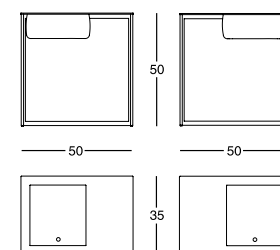

Struttura/Frame/Structure/Gestell/Estructura





Design

Prospero Rasulo

2001

Tavolino-portaoggetti
Coni in poliuretano rigido, asta di sostegno in acciaio, laccatura lucida nei colori talco, cera, lilla, canapa, caramello, arancione, amaranto, verde prato, espresso o nero.

Small table/stand
Stiff polyurethane cones, steel stem, glossy lacquer in the colours talc, wax, lilac, hemp, caramel, orange, amaranth, grass green, espresso or black.

Table basse/porte-objets
Cônes en polyuréthane rigide, tige de soutien en acier, laquage brillant dans les couleurs talc, cire, lilas, chanvre, caramel, orange, rouge amarante, vert pré, espresso ou noir.

Tischchen/Ablage
Kegel aus steifem Polyurethan, Trägerstange aus Stahl mit poliertem Glanzlack in den Farben Talkum, Wachs, Flieder, Hanf, Karamell, Orange, Amarantröt, grasgrün, Espresso oder schwarz.

Mesita/porta objetos
Conos de poliuretano rígido, asta central de acero, lacados brillante en los colores talco, cera, lila, cañamo, naranja, caramelo, granate, verde prato, espresso o negro.

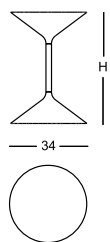

H 36 cm
H 50 cm

Struttura/Frame/Structure/Gestell/Estructura



Design

Prospero Rasulo

2006

IN/OUT

Tavolino
Struttura in gres fine porcellanato antigelo per esterni, con doppia smaltatura manuale a spessore controllato, cotto a 1250°C con un ciclo di lavorazione di 36 ore, colore verde-giallo.

Occasional table
Freeze resistant frame in fine porcelainized grès for outdoors use with thickness controlled two-layering applied by hand and baked at 1250°C with a 36-hour processing cycle, colour green-yellow..

Petite table
Structure en grès fin émaillé résistante au gel pour externes, avec double émaillage manuel à épaisseur contrôlée, cuit à 1250°C en appliquant un cycle d'oeuvre de 36 heures, couleur vert-jaune.

Couchtisch
Gestell aus frostfestem und wetter-beständigem Feinsteinzeug, doppelte, dickenkontrollierte Handglasur, über 36 Stunden bei 1250 °C gebrannt, Farbe grün-gelb.

Mesita
Estructura de gres fino porcelánico antihielo para uso exterior, con doble capa de esmalte a mano de espesor controlado, cocido a 1250°C con un ciclo de elaboración de 36 horas, color verde-amarillo.

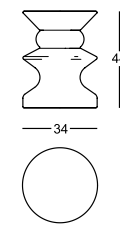



Design

Todd Bracher

2005

Tavolino

Struttura in polipropilene, laccatura lucida nei colori talco, cera, canapa, caramello, arancione, amaranto, verde prato, espresso o nero.

Small table

Polypropylene frame and glossy lacquer finish in the colours talc, wax, hemp, caramel, orange, amaranth, grass green, espresso or black.

Petite table

Structure en polypropylène, laquage brillant dans les couleurs talc, cire, chanvre, caramel, orange, rouge amarante, vert pré, espresso ou noir.

Tischchen

Gestell aus Polypropylen, glanzlackiert in den Farben Talkum, Wachs, Hanf, Karamell, Orange, amarantrot, grasgrün, Espresso oder schwarz.

Mesita

Estructura de polipropileno, lacado brillante en los colores talco, cera, cañamo, naranja, caramelo, granate, verde prato, espresso o negro.

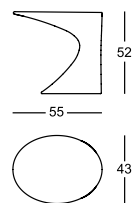

Struttura/Frame/Structure/Gestell/Estructura



Design

Salvatore Indriolo

2012

Tavolino

Struttura in poliuretano rigido. Piano in multistrato placcato alluminio. Verniciatura nei colori talco, amaranto o nero. Il piano superiore ruotando a 360° permette l'accesso ad un vano portaoggetti sottostante.

Small table

Stiff polyurethane frame. Aluminum-covered plywood top. Varnish in talc, amaranth or black. Organizer compartment revealed by rotating tabletop 360°.

Petite table

Structure en polyuréthane rigide. Plateau en multicouche plaqué aluminium. Peinture en talc, rouge amarante ou noire. Le plateau supérieur tourne à 360° et permet ainsi d'accéder à un espace porte-objets situé dessous.

Couchtisch

Gestell aus steifem Polyurethan. Furnierholzplatte mit Aluminium beschichtet. Lackierung in den Farben Talkum, amarantrot oder schwarz. Die Platte lässt sich über einem darunterliegenden Staufach um 360° drehen.

Mesita

Estructura de poliuretano rígido. Sobre en multicapa chapado de aluminio. Lacado en color talco, granate o negro. Girando 360° el sobre superior se accede a un compartimiento portaobjetos inferior.

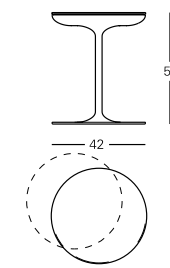

Struttura/Frame/Structure/Gestell/Estructura





Design

Bertrand Lejoly

2022

Tavolini

Struttura in acciaio verniciato colore nero opaco. Piani in lamiera di acciaio rivestiti in cuoio pigmentato 90 nei colori gold, nero, antracite e fango in abbinamento al piede in faggio laccato colore nero lucido, oppure piani in marmo bianco di Carrara o verde Alpi, in abbinamento rispettivamente al piede in faggio laccato colore bianco lucido RAL 9010 o verde lucido RAL 6012.

Coffee tables

Matt black varnished steel frame. Steel sheet tops, covered with cowhide pigmentato 90 in the shades gold, black, anthracite and mud matching the foot in glossy black painted beech; or tops made of white Carrara or green Alpi marbles, matching the foot respectively in glossy white RAL 9010 painted or glossy green RAL 6012 painted beech.

Petites tables

Structure en acier verni noir mat. Plateaux en tôle d'acier recouverts de cuir sellier pigmentato 90 dans les couleurs gold, noir, anthracite et boue en combinaison avec le pied en hêtre laqué noir brillant, ou plateaux en marbre blanc de Carrara ou Alpi vert, en combinaison respectivement avec le pied en hêtre laqué blanc brillant RAL 9010 ou vert brillant RAL 6012.

Beistelltische

Stahlgestell schwarz matt lackiert. Platten aus Stahlblech, bezogen mit Kernleder pigmentato 90 in den Farben gold, schwarz, anthrazit und Schlamm, passend zum Fuß aus glänzend schwarz lackiertem Eschenholz; oder Platten aus weißem Carrara-Marmor oder grünem Alpi-Marmor, passend zum Fuß bzw. aus glänzend weiß RAL 9010 - oder glänzend grün RAL 6012 lackiertem Eschenholz.

Mesitas

Estructura en acero pintado en negro mate. Sobres en chapa de acero recubiertas de cuero pigmentato 90 en los colores gold, negro, antracita y barro en combinación con el pie en haya lacada en negro brillante, o sobres en mármol blanco de Carrara o Alpi verde, en combinación respectivamente con el pie en haya lacada en blanco brillante RAL 9010 o verde brillante RAL 6012.

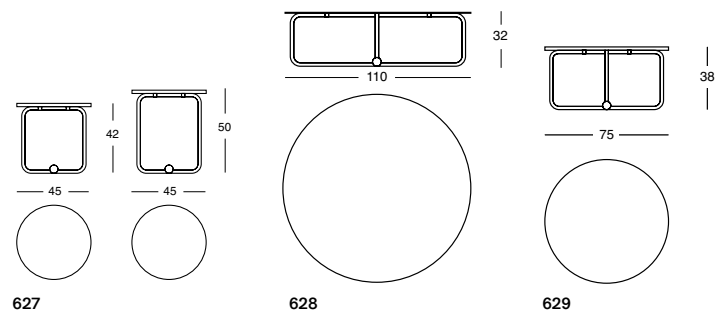

Piani/Tops/Plateaux/Platten/Sobres



Marmo di Carrara/
Carrara marble/
Marbre de Carrare/Carrara Marmor/Mármol de Carrara

Marmo Alpi/Alpi marble/Marbre Alpi/Alpi Marmor/Mármol Alpi



Design

Garcia Cumini

2021

Tavolini

Piano in legno placcato in rovere verniciato colore naturale, o a poro aperto colore nero, oppure laccato in noce Canaletto. Sotto piano verniciato colore nero. Gambe in tubolare di acciaio verniciato colore nero opaco.

Small tables

Top available either in natural painted oak veneered wood, or black painted with open pore, or in Canaletto walnut veneered wood. Black painted under-top. Legs in tubular stainless steel, matt black painted.

Petites tables

Plateau en bois plaqué en rovere verni couleur naturel, ou verni à pore ouvert de couleur noire, ou plaqué en noyer Canaletto. Le plateau au-dessous est verni couleur noire. Pieds en acier tubulaire vernis couleur noir mat.

Beistelltische

Holzplatte furniert mit naturfarben lackierter Eiche, oder schwarz lasiert, oder mit Nussbaum Canaletto. Schwarz lackierte Unterplatte. Beine aus matten schwarz- lackierten Stahlrohr.

Mesitas

Superficie de madera chapado en roble barnizado natural, o pintado a poro abierto en color negro, o chapado en nogal Canaletto. La parte inferior del sobre es pintado de color negro. Patas en acero tubular pintado de color negro mate.

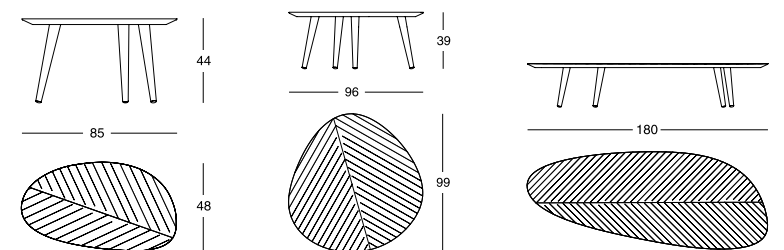

Piani/Tops/Plateaux/Platten/Sobres

Rovere naturale/
Natural oakwood/
Rouvre naturel/
Naturfarbene Eiche/Roble natural



Rovere tinto nero/
Black varnished oak/Rouvre teinté noir/Schwarz-gebeizte Eiche/Roble teñido negro



Noce Canaletto/
Canaletto walnut/
Noyer Canaletto/
Nussbaum Canaletto/Nogal Canaletto



Tweed Mini ⁶⁶⁴

NEW PRODUCT



Design

Garcia Cumini

2021

Tavolini

Piano in MDF spessore 30 mm, laccato opaco colore canapa, amaranto, espresso, antracite e nero. Gambe in tubolare di acciaio verniciato colore nero opaco.

Small tables

MDF top, thickness 30 mm, matt lacquered in the colours hemp, amaranth, espresso, anthracite and black. Legs in tubular stainless steel, matt black painted.

Petites tables

Plateau en MDF, épaisseur 30 mm, verni mat dans les couleurs chanvre, rouge amarante, espresso, anthracite et noir. Pieds en acier tubulaire vernis couleur noir mat.

Beistelltische

MDF-Platte, Stärke 30 mm, matt lackiert in den Farben Hanf, Amaranth, Espresso, Anthrazit und schwarz. Beine aus matt schwarz-lackiertem Stahlrohr.

Mesitas

Sobre de MDF, espesor 30 mm, lacado mate en los colores cáñamo, granate, espresso, antracita y negro. Patas en acero tubular pintado de color negro mate.

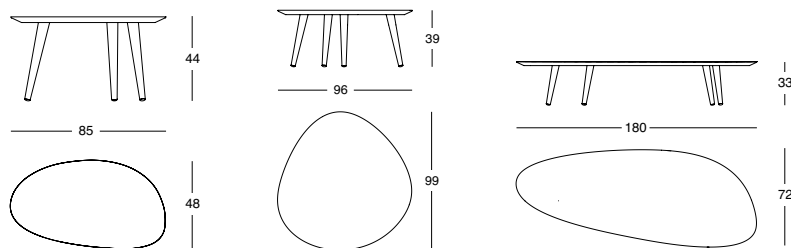

Piani/Tops/Plateaux/Platten/Sobres



Z24 Nightstand ⁷²⁸

NEW PRODUCT



Design

Muller Van Severen

2024

Comodino

Struttura in MDF e legno listellare, laccatura opaca nei colori talco, cera, canapa, caramello, arancione, amaranto, verde prato, espresso e nero. Ripiano interno regolabile in cristallo temperato.

Nightstand

Frame in MDF and blockboard wood, matt lacquered in the colours talc, wax, hemp, caramel, orange, amaranth, grass green, espresso and black. Adjustable internal shelf in tempered plate glass.

Table de chevet

Structure en MDF et bois à lamelles, laquée mat dans les couleurs talc, cire, chanvre, caramel, orange, rouge amarante, vert pré, espresso et noir. Plateau intérieure réglable en verre trempé.

Nachtisch

Gestell aus MDF und Lattenholz matt lackiert in den Farben Talkum, Wachs, Hanf, Karamell, Orange, Amaranth, grasgrün, Espresso und schwarz. Verstellbares inneres Regal aus gehärtetem Kristallglas.

Mesita de noche

Estructura de MDF y listones de madera, lacada mate en los colores talco, cera, cáñamo, caramelo, naranja, granate, verde prado, espresso y negro. Estante interior regulable de cristal templado.

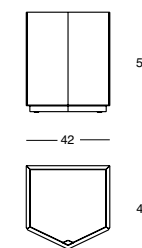

Struttura/Frame/Structure/Gestell/Estructura



Zavolo Coffee Table 790/791

NEW PRODUCT



Design

Zaven

2024

Tavolini

Struttura in MDF, laccatura opaca nei colori talco, cera, canapa, caramello, arancione, amaranto, verde prato, espresso e nero.

Small tables

MDF frame, matt lacquered in the colours talc, wax, hemp, caramel, orange, amaranth, grass green, espresso and black.

Petites tables

Structure en MDF, laquée mat dans les couleurs talc, cire, chanvre, caramel, orange, rouge amarante, vert pré, espresso et noir.

Beistelltische

Gestell aus MDF, matt lackiert in den Farben Talkum, Wachs, Hanf, Karamell, Orange, Amarantröt, grasgrün, Espresso und schwarz.

Mesitas

Estructura de MDF, lacado mate en los colores talco, cera, cáñamo, caramelo, naranja, granate, verde prado, espresso y negro.

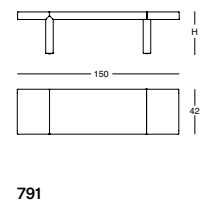
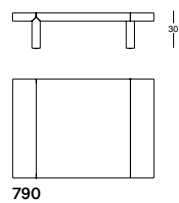

Dimensioni/Sizes/Dimensions/Abmessungen/Medidas

790
84x120 cm
84x150 cm
120x120 cm

791
150x42 /H30 cm
150x42/H40 cm

Struttura/Frame/Structure/Gestell/Estructura



Zeus 6005



Design

Prospero Rasulo

2006

IN/OUT

Tavolino

Struttura in gres fine porcellanato antigelivo per esterni, con doppia smaltatura manuale a spessore controllato, cotto a 1250°C con un ciclo di lavorazione di 36 ore, colore blu-marrone.

Occasional table

Freeze resistant frame in fine porcelainized grès for outdoors use with thickness controlled two-layering applied by hand and baked at 1250°C with a 36-hour processing cycle, colour blue brown.

Petite table

Structure en grès fin émaillé résistante au gel pour externes, avec double émaillage manuel à épaisseur contrôlée, cuit à 1250°C en appliquant un cycle d'oeuvre de 36 heures, couleur bleu-brun.

Couchtisch

Gestell aus frostfestem und wetter-beständigem Feinsteinzeug, doppelte, dickenkontrollierte Handglasur, über 36 Stunden bei 1250 °C gebrannt, Farbe blau-braun.

Mesita

Estructura de gres fino porcelánico antihielo para uso exterior, con doble capa de esmalte a mano de espesor controlado, cocido a 1250°C con un ciclo de elaboración de 36 horas, color azul-marrón.

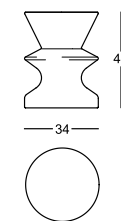



Design

Gae Aulenti

1964

IN/OUT

Sedia pieghevole

Struttura in acciaio inox. Snodi in lega di alluminio. Rivestimento sfilabile in Vip (per esterni), in Telastrong o in cuoio 95.

Folding chair

Stainless steel frame. Aluminum alloy joints. Removable cover in Vip (for outdoors), in Telastrong, or in cowhide 95.

Chaise pliante

Structure en acier inox. Articulations en alliage d'aluminium. Revêtement déhoussable en Vip (pour extérieurs), en Telastrong, ou en cuir sellier 95.

Klappsessel

Gestell aus Inox-Stahl. Gelenke aus Aluminiumlegierung. Abnehmbarer Bezug aus Vip (fürs Freie), aus Telastrong, oder aus Kernleder 95.

Silla plegable

Estructura de acero inox. Articulaciones de aleación de aluminio. Tapizado desenfundable de Vip (para exteriores), de Telastrong, o de cuero 95.

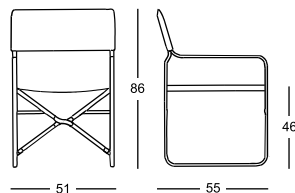

Design

Marco Zanuso

1978

Sedia pieghevole

Struttura in acciaio verniciato, colore talco o nero. Sedile e schienale in nylon ricoperti in cuoio 95.

Folding chair

Frame in talc or black painted steel. Nylon seat and back covered in cowhide 95.

Chaise pliante

Structure en acier verni talc ou noir. Assise et dossier en nylon recouverts de cuir sellier 95.

Klappstuhl

Gestell aus Talkum oder schwarz lackiertem Stahl. Sitzfläche und Rückenlehne aus Nylon mit Kernleder 95 bezogen.

Silla plegable

Estructura de acero pintado en los colores: talco o negro. Asiento y respaldo de nylon tapizados de cuero 95.

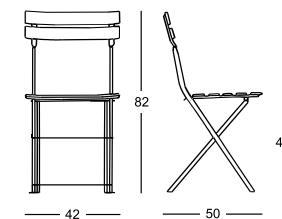

Struttura/Frame/Structure/ Gestell/Estructura



Dan Outdoor 2073/2074

Daisy 2125



Design

Patrick Norguet

2020

IN/OUT

Sedia per esterni con o senza braccioli

Struttura in acciaio verniciato per esterno colore grigio ferro o nero opaco. Seduta e schienale realizzati con nastri elastici in filato di poliestere nei colori giallo, corda, antracite e blu. Il logo Zanotta è stampato sulla parte posteriore della cinghia inferiore dello schienale.

Outdoor chair with or without armrests

Steel frame varnished for outdoor iron grey or matt black. Seat and backrest made of elastic straps in polyester thread available in yellow, string, anthracite and blue. The Zanotta logo is printed on the back of the lower backrest strap.

Chaise pour extérieur avec ou sans accoudoirs

Structure en acier verni gris fer ou noir mat pour extérieur. Assise et dossier réalisés avec des rubans élastiques en fil de polyester dans les couleurs jaune, corde, anthracite et bleu. Le logo Zanotta est imprimé à l'arrière du ruban inférieur du dossier.

Stuhl fürs Freie mit oder ohne Armlehnen

Gestell aus fürs Freie eisengrauem oder mattem schwarz-lackierten Stahl. Sitz und Rückenlehne bestehen aus Gummibändern in Polyestergeram in den Farben Gelb, Schnur, anthrazit und blau. Das Zanotta Logo ist auf die Rückseite des unteren Rückengurtes gedruckt.

Silla para exteriores con o sin apoyabrazos

Estructura de acero pintado en los colores gris hierro o negro mate para exteriores. Asiento y respaldo realizados con cintas elásticas de poliéster en los colores amarillo, cuerda, antracita y azul. El logo Zanotta está impreso en la parte posterior de la cinta elástica inferior del respaldo.

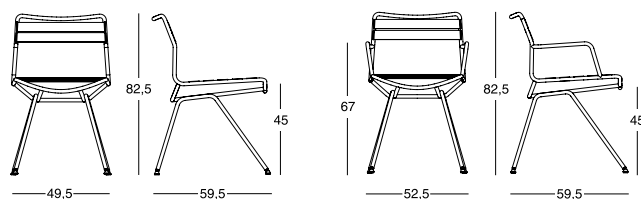

2073

2074

Struttura/Frame/Structure/ Gestell/Estructura



Seduta/Seat/Siège/Sitz/Asiento



Design

Mist-o

2023

Sedia sovrapposibile

Gambe in lega di alluminio verniciato colore talco o nero. Sedile in multistrato con imbottitura in poliuretano schiumato autoestinguente. Struttura schienale in acciaio con imbottitura in poliuretano schiumato autoestinguente. Rivestimento sfilabile in stoffa o in pelle.

Stackable chair

Aluminum alloy legs painted talc or black. Plywood seat with self-extinguishing polyurethane foam upholstery. Steel backrest frame with self-extinguishing polyurethane foam upholstery. Removable cover in fabric or leather.

Chaise superposable

Pieds en alliage d'aluminium verni, couleur talc ou noir. Siège en multicouche avec rembourrage en mousse de polyuréthane autoextinguible. Structure dossier en acier avec rembourrage en mousse de polyuréthane autoextinguible. Revêtement déhoussable en tissu ou en cuir.

Stapelbarer Stuhl

Beine aus Talkum oder schwarz lackierter Alu-Legierung. Sitz aus Sperrholz mit selbstlöschendem Polyurethanschaum gepolstert. Rückenlehne aus Stahl mit selbstlöschendem Polyurethanschaum gepolstert. Abnehmbarer Bezug aus Stoff oder Leder.

Silla apilable

Patas de aleación de aluminio pintado talco o negro. Asiento de madera contrachapada con acolchado de espuma de poliuretano autoextintivo. Respaldo de acero con acolchado de espuma de poliuretano autoextintivo. Tapizado desenfundable de tejido o piel.

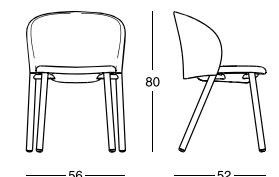

Gambe/Legs/Pieds/Beine/Patas





Design

Calvi Brambilla

2024

Poltroncina

Struttura in acciaio. Imbottitura struttura in poliuretano schiumato autoestingente. Imbottitura cuscino di seduta realizzata con sfere di poliestere

rigenerato e rigenerabile. Rivestimento amovibile in stoffa. La poltroncina è disponibile in versione fissa o in versione girevole.

Small armchair

Steel frame. Frame upholstered with self-extinguishing polyurethane foam. Seat cushion upholstered with regenerated and regenerable

polyester balls. Removable fabric cover. The small armchair is available in a fixed or swivel version.

Petit fauteuil

Structure en acier. Rembourage de la structure en mousse de polyuréthane autoextinguible. Coussin assise en boules de polyester régénéré et régénérable.

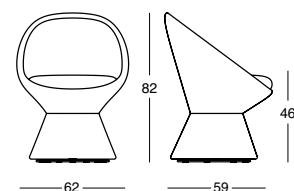

Revêtement amovible en tissu. Le petit fauteuil est disponible en version fixe ou pivotante.

Kleiner Sessel

Gestell aus Stahl. Selbstverlöschende Polyurethanschaum-Polsterung des Gestells. Sitz-Kissen aus regenerierten und regenerierbaren

Polyesterkugeln. Abnehmbarer Bezug aus Stoff. Der kleine Sessel ist in einer festen oder drehbaren Version erhältlich.

Butaquita

Estructura de acero. Acolchado de la estructura de espuma de poliuretano autoextinguible. Cojín de asiento en bolas de poliéster regenerado y regenerable.

Tapizado desenfundable en tejido. La butaquita está disponible en versión fija o giratoria

Fenis CM ²⁰⁵¹



Omaggio a

Carlo Mollino

1959

Sedia
Struttura in legno massello di acero verniciato colore naturale o nero.

Chair
Frame in natural or black painted solid maple wood.

Chaise
Structure en érable massif verni couleur naturel ou noir.

Stuhl
Gestell aus massivem Ahornholz, naturfarben oder schwarz lackiert.

Silla
Estructura de madera de arce maciza con acabado en color natural o negro.

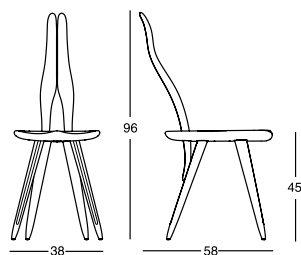

Struttura/Frame/Structure/ Gestell/Estructura



Ido ²²⁸⁶



Design

Frank Rettenbacher

2016

Sgabelli
Struttura in legno massello di rovere o noce Canaletto verniciati, colore naturale. Poggiapiedi in acciaio inox satinato.

Stools
Frame in solid oak or Canaletto walnut, natural painted. Footrest in satin-finished stainless steel.

Tabourets
Structure en bois massif de rouvre ou noyer Canaletto, vernis naturel. Appuie-pieds en acier inox satiné.

Hocker
Gestell aus Massivholz in Eiche oder Nussbaum Canaletto, beide naturfarben lackiert. Fußstütze aus satiniertem Stahl.

Taburetes
Estructura de madera maciza de roble o nogal Canaletto, barnizados natural. Reposapiés de acero inox satinado.

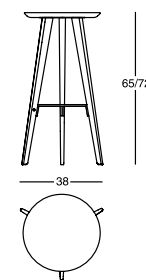

2286/A 38 x 72 cm
2286/B 38 x 65 cm

Rovere naturale/Natural oakwood/Rouvre naturel/Naturfarbene Eiche/Roble natural



Noce Canaletto/Canaletto walnut/Noyer Canaletto/Nussbaum Canaletto/Nogal Canaletto



Lea ^{2083/84/85}



Design

Roberto Barbieri

2003

Sedia

Sedia con braccioli
Struttura in lega di alluminio. Sedile, schienale e braccioli imbottiti in poliuretano. Rivestimento sfilabile in stoffa o in pelle oppure non sfilabile in cuoio. A richiesta viene fornita una fodera coprisedia da calzare senza fissare: in tessuto 100% cotone, colore bianco, disponibile sia corta che ricopre sedile e schienale, sia lunga che ricopre anche le gambe.

Chair

Chair with armrests
Aluminium alloy frame. Seat, back and armrests upholstered in polyurethane. Removable cover in fabric or leather or non-removable in cowhide. Upon request one loose cover to be put on without fixing can be supplied: in 100% white cotton, available either short covering seat and backrest or long covering legs too.

Chaise

Chaise avec accoudoirs
Structure en alliage d'aluminium. Siège, dossier et accoudoirs rembourrés en polyuréthane. Revêtement déhoussable en tissu ou en cuir ou pas déhoussable en cuir sellier. Sur demande on peut fournir une housse à poser sans la fixer pour protéger les chaises: en tissu 100% coton, couleur blanche, dans les versions courte qui couvre assise et dossier ou longue qui couvre même les pieds.

Stuhl

Stuhl mit Armlehnen
Gestell aus Alu-Legierung. Sitz, Rückenlehne und Armlehnen Polyurethan-gepolstert. Abnehmbarer Bezug aus Stoff oder Leder oder aus nicht abnehmbarem Kernleder. Auf Nachfrage ist ein loser Bezug verfügbar, der auf dem Stuhl ohne befestigen anzuziehen ist: aus 100% weißer Baumwolle, in zwei Versionen lieferbar, kurz, der Sitz und Rücken überzieht, oder lang, der auch die Beine überzieht.

Silla

Silla con apoyabrazos
Estructura de aleación de aluminio. Asiento, respaldo y apoyabrazos acolchados en poliuretano. Tapizado desenfundable de tejido o de piel o no desenfundable de cuero. A pedido suministramos una funda de poner sobre la silla sin fijarla: de tejido 100% algodón, color blanco, disponible corta que cubre asiento y respaldo o larga que cubre también las patas.

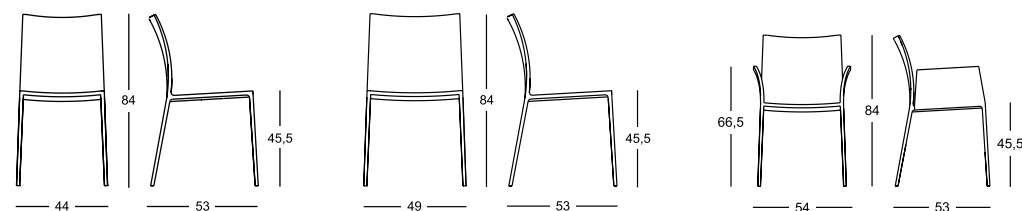

2083

2084

2085

Lealta ²⁰⁸¹



Design

Roberto Barbieri

2006

Sedia

Struttura in lega di alluminio. Sedile e schienale imbottiti in poliuretano. Rivestimento sfilabile in stoffa o in pelle oppure non sfilabile in cuoio. A richiesta viene fornita una fodera coprisedia da calzare senza fissare: in tessuto 100% cotone, colore bianco, disponibile sia corta che ricopre sedile e schienale, sia lunga che ricopre anche le gambe.

Chair

Aluminium alloy frame. Seat and back upholstered in polyurethane. Removable cover in fabric or leather or non-removable in cowhide. Upon request one loose cover to be put on without fixing can be supplied: in 100% white cotton, available either short covering seat and backrest or long covering legs too.

Chaise

Structure en alliage d'aluminium. Siège et dossier rembourrés en polyuréthane. Revêtement déhoussable en tissu ou en cuir ou pas déhoussable en cuir sellier. Sur demande on peut fournir une housse à poser sans la fixer pour protéger les chaises: en tissu 100% coton, couleur blanche, dans les versions courte qui couvre assise et dossier ou longue qui couvre même les pieds.

Stuhl

Gestell aus Aluminiumlegierung. Sitz und Rückenlehne Polyurethan-gepolstert. Abnehmbarer Bezug aus Stoff oder Leder oder aus nicht abnehmbarem Kernleder. Auf Nachfrage ist ein loser Bezug verfügbar, der auf dem Stuhl ohne befestigen anzuziehen ist: aus 100% weißer Baumwolle, in zwei Versionen lieferbar, kurz, der Sitz und Rücken überzieht, oder lang, der auch die Beine überzieht.

Silla

Estructura de aleación de aluminio. Asiento y respaldo acolchados en poliuretano. Tapizado desenfundable de tejido o de piel o no desenfundable de cuero. A pedido suministramos una funda de poner sobre la silla sin fijarla: de tejido 100% algodón, color blanco, disponible corta que cubre asiento y respaldo o larga que cubre también las patas.

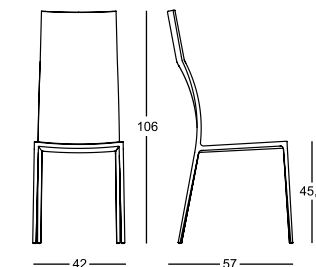



Design

Roberto Barbieri

1998-1999

Sedia

Sedia con braccioli
Struttura in lega di alluminio lucidato oppure verniciato, colore talco, grafite o nero. Sedile, schienale e braccioli imbottiti in poliuretano. Rivestimento sfilabile in stoffa o in pelle oppure non sfilabile in cuoio. A richiesta viene fornita una fodera copriesedia da calzare senza fissare: in tessuto 100% cotone, colore bianco, disponibile sia corta che ricopre sedile e schienale, sia lunga che ricopre anche le gambe.

Chair

Chair with armrests
Aluminum alloy frame, polished or painted talc, graphite or black. Seat and armrests upholstered in polyurethane. Removable cover in fabric or leather or non-removable in cowhide. Upon request one loose cover to be put on without fixing can be supplied: in 100% white cotton, available either short covering seat and backrest or long covering legs too.

Chaise

Chaise avec accoudoirs
Structure en alliage d'aluminium poli ou verni couleur talc, graphite ou noir. Siège, dossier et accoudoirs rembourrés en polyuréthane. Revêtement déhoussable en tissu ou en cuir ou pas déhoussable en cuir sellier. Sur demande on peut fournir une housse à poser sans la fixer pour protéger les chaises: en tissu 100% coton, couleur blanche, dans les versions courte qui couvre assise et dossier ou longue qui couvre même les pieds.

Stuhl

Stuhl mit Armlehnen
Gestell aus polierter Aluminiumlegierung oder Talkum, Graphit oder schwarz lackiert. Sitz, Rückenlehne und Armlehnen Polyurethan-gepolstert. Abnehmbarer Bezug aus Stoff oder Leder oder aus nicht abnehmbarem Kernleder. Auf Nachfrage ist ein loser Bezug verfügbar, der auf dem Stuhl ohne befestigen anzuziehen ist: aus 100% weißer Baumwolle, in zwei Versionen lieferbar, kurz, der Sitz und Rücken überzieht, oder lang, der auch die Beine überzieht.

Silla

Silla con apoyabrazos
Estructura de aleación de aluminio pulido o barnizado color talco, grafito o negro. Asiento, respaldo y apoyabrazos acolchados en poliuretano. Tapizado desenfundable de tejido o de piel o no desenfundable de cuero. A pedido suministramos una funda de poner sobre la silla sin fijarla: de tejido 100% algodón, color blanco, disponible sia corta que cubre asiento y respaldo o larga que cubre tambien las patas.

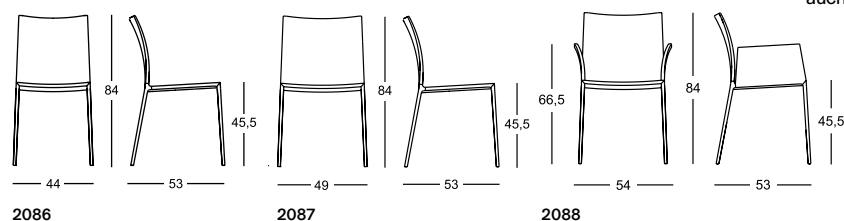

Struttura/Frame/Structure/ Gestell/Estructura



Design

Roberto Barbieri

2006

Sedia

Struttura in lega di alluminio lucidato oppure verniciato colore talco, grafite o nero. Sedile e schienale imbottiti in poliuretano. Rivestimento sfilabile in stoffa o in pelle oppure non sfilabile in cuoio. A richiesta viene fornita una fodera copriesedia da calzare senza fissare: in tessuto 100% cotone, colore bianco, disponibile sia corta che ricopre sedile e schienale, sia lunga che ricopre anche le gambe.

Chair

Aluminum alloy frame, polished or painted talc, graphite or black. Seat and back upholstered in polyurethane. Removable cover in fabric or leather or non-removable in cowhide. Upon request one loose cover to be put on without fixing can be supplied: in 100% white cotton, available either short covering seat and backrest or long covering legs too.

Chaise

Structure en alliage d'aluminium poli ou verni couleur talc, graphite ou noir. Siège et dossier rembourrés en polyuréthane. Revêtement déhoussable en tissu ou en cuir ou pas déhoussable en cuir sellier. Sur demande on peut fournir une housse à poser sans la fixer pour protéger les chaises: en tissu 100% coton, couleur blanche, dans les versions courte qui couvre assise et dossier ou longue qui couvre même les pieds.

Stuhl

Gestell aus polierter Aluminiumlegierung oder Talkum, Graphit oder schwarz lackiert. Sitz und Rückenlehne Polyurethan-gepolstert. Abnehmbarer Bezug aus Stoff oder Leder oder aus nicht abnehmbarem Kernleder. Auf Nachfrage ist ein loser Bezug verfügbar, der auf dem Stuhl ohne befestigen anzuziehen ist: aus 100% weißer Baumwolle, in zwei Versionen lieferbar, kurz, der Sitz und Rücken überzieht, oder lang, der auch die Beine überzieht.

Silla

Estructura de aleación de aluminio pulido o barnizado color talco, grafito o negro. Asiento y respaldo acolchados en poliuretano. Tapizado desenfundable de tejido o de piel o no desenfundable de cuero. A pedido suministramos una funda de poner sobre la silla sin fijarla: de tejido 100% algodón, color blanco, disponible sia corta que cubre asiento y respaldo o larga que cubre tambien las patas.

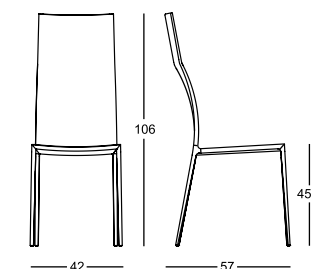

Struttura/Frame/Structure/ Gestell/Estructura





Design

Roberto Barbieri

2005

Sgabelli

Struttura in lega di alluminio (2292) oppure in lega di alluminio lucidato o verniciato colore talco, grafite o nero (2291). Sedile e schienale imbottiti in poliuretano. Rivestimento sfilabile in stoffa o in pelle oppure non sfilabile in cuoio. Poggiapiedi in acciaio inox satinato. A richiesta viene fornita una fodera copri sgabello, in tessuto 100% cotone, colore bianco, da calzare senza fissare, che ricopre sedile e schienale.

Stools

Frame in aluminum alloy (2292) or in polished aluminum alloy, or painted talc, graphite or black (2291). Seat and back with polyurethane upholstery. Removable cover in fabric or leather or non-removable in cowhide. Footrest in satin-finished stainless steel. Upon request a 100% white cotton loose stool cover to be put on without fixing, covering seat and backrest, can be supplied.

Tabourets

Structure en alliage d'aluminium (2292) ou en alliage d'aluminium poli, ou verni couleur talc, graphite ou noir (2291). Assise et dossier rembourrés en polyuréthane. Revêtement déhoussable en tissu ou en cuir ou pas déhoussable en cuir sellier. Appuie-pieds en acier inox satiné. Sur demande on va fournir une housse qui protège le tabouret en tissu 100% coton, couleur blanche, de poser sans la fixer, qui couvre assise et dossier.

Hocker

Gestell aus Aluminiumlegierung (2292) oder aus polierter Aluminiumlegierung, oder Talkum, Graphit oder schwarz lackiert (2291). Sitz und Rückenlehne mit Polsterung aus Polyurethan. Abnehmbarer Außenbezug aus Stoff oder Leder oder aus nicht abnehmbarem Kernleder. Fußstütze aus satiniertem Edelstahl. Auf Nachfrage ist ein loser Bezug aus 100% weißer Baumwolle lieferbar, der auf dem Hocker ohne Befestigen anzuziehen ist und Sitz und Rücken überzieht.

Taburetes

Estructura de aleación de aluminio (2292) o de aleación de aluminio pulido o barnizado color talco, grafite o negro (2291). Asiento y respaldo acolchados de poliuretano. Tapizado desenfundable de tejido o de piel o no desenfundable de cuero. Reposapiés de acero inoxidable satinado. A pedido suministramos una funda que protege el taburete de tejido 100% algodón, color blanco, de poner sobre el taburete sin fijarla, que cubre asiento y respaldo.

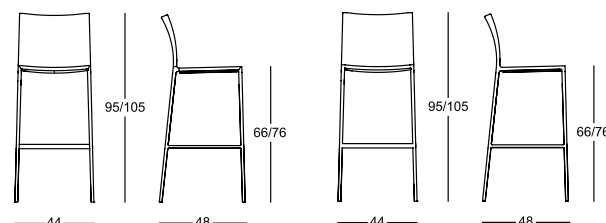

2291/A h 76 cm / 2291/B h 66 cm

2292/A h 76 cm / 2292/B h 66 cm

Struttura/Frame/Structure/ Gestell/Estructura (mod. 2291)



Design

Alfredo Häberli

2003

Poltroncina girevole e reclinabile

Base a cinque razze in lega di alluminio lucidato con rotelle o con piedini (2278/P). Altezza seduta regolabile. Schienale reclinabile, con comando, fissabile in cinque posizioni diverse o oscillante in maniera continua. Imbottitura in poliuretano con molleggio su nastri elastici. Cuscino seduta, a richiesta, in poliuretano/Dacron Du Pont. Rivestimento sfilabile in stoffa o in pelle.

Reclining swivel armchair

Five-spoke base in polished aluminum alloy with castors or feet (2278/P). Adjustable seat height. The tilting back, with controls, can be set in five different positions or made to constantly rock. Polyurethane upholstery with elastic strips suspension. Seat cushion in polyurethane/Dacron Du Pont, on request. Removable fabric or leather cover.

Petit fauteuil tournant et inclinable

Base à cinq rayons en alliage d'aluminium poli à roulettes ou pieds (2278/P). Hauteur du siège réglable. Le dossier inclinable par commande peut être fixé dans cinq positions différentes ou basculer de manière continue. Rembourrage en polyuréthane avec suspension sur sangles élastiques. Sur demande, coussin du siège en polyuréthane/Dacron Du Pont. Revêtement déhoussable en tissu ou en cuir.

Verstellbarer Drehsessel

Fünfeiniger Fuß aus polierter Aluminiumlegierung auf Rollen oder mit festen Füßen (2278/P). Sitzhöhe regulierbar. Neigung der Lehne über Mechanismus verstellbar, in fünf Positionen zu fixieren oder stufenlos beweglich. Polsterung aus Polyurethan mit Federung auf elastischen Gurten. Auf Wunsch Sitzkissen aus Polyurethan/Dacron Du Pont. Abnehmbarer Bezug aus Stoff oder Leder.

Sillón giratorio y reclinable

Base con cinco radios en aleación de aluminio pulido con ruedas o patas (2278/P). Altura del asiento regulable. Respaldo reclinable, mediante control, se puede fijar en cinco posiciones diferentes o oscilar de forma continua. Acolchado de poliuretano con suspensión sobre cintas elásticas. Cojín del asiento, a pedido, en poliuretano/Dacron Du Pont. Tapizado desenfundable de tejido o de piel.

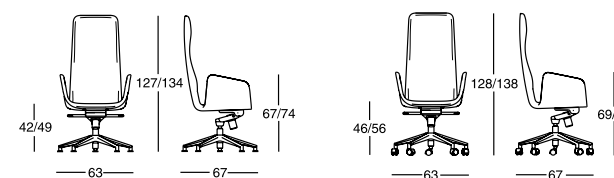



Design

Lanzavecchia+Wai

2020

Poltroncina

Struttura in acciaio verniciato colore arancione, amaranth, espresso, grafite o nero. Imbottitura sedile e schienale in poliuretano. Rivestimento sfilabile in stoffa o in pelle.

Armchair

Steel frame varnished orange, amaranth, espresso, graphite or black. Seat and backrest upholstered with polyurethane. Removable fabric or leather cover.

Petit fauteuil

Structure en acier verni orange, rouge amarante, espresso, graphite ou noir. Assise et dossier rembourrés en polyuréthane. Revêtement déhoussable en tissu ou en cuir.

Sessel

Gestell aus orange, amaranth, espresso, graphit oder schwarz lackiertem Stahl. Sitz- und Rückenlehne Polsterung mit Polyurethan gepolstert. Abnehmbarer Bezug aus Stoff oder Leder.

Butaquita

Estructura de acero pintado en los colores naranja, granate, espresso, grafito o negro. Acolchado del asiento y del respaldo en poliuretano. Tapizado desenfundable de tejido o piel.

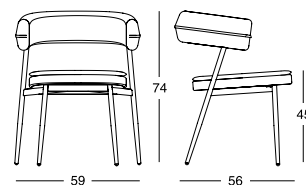

Struttura/Frame/Structure/ Gestell/Estructura



Design

Lanzavecchia+Wai

2022

Sgabello

Struttura in acciaio verniciato colore arancione, amaranth, espresso, grafite o nero. Imbottitura sedile e schienale in poliuretano. Rivestimento sfilabile in stoffa o in pelle. Poggiapiedi ricoperto in acciaio inox satinato.

Stool

Steel frame varnished orange, amaranth, espresso, graphite or black. Seat and backrest upholstered with polyurethane. Removable fabric or leather cover. Footrest covered with satin-finished stainless steel.

Tabouret

Structure en acier verni orange, rouge amarante, espresso, graphite ou noir. Assise et dossier rembourrés en polyuréthane. Revêtement déhoussable en tissu ou en cuir. Appuie-pieds recouvert en acier inox satiné.

Hocker

Gestell aus orange, amaranth, espresso, graphit oder schwarz lackiertem Stahl. Sitz- und Rückenlehne Polsterung mit Polyurethan gepolstert. Abnehmbarer Bezug aus Stoff oder Leder. Fußstütze bezogen mit satiniertem Inox-Stahl.

Taburete

Estructura de acero pintado en los colores naranja, granate, espresso, grafito o negro. Acolchado del asiento y del respaldo en poliuretano. Tapizado desenfundable de tejido o piel. Reposapiés recubierto de acero inoxidable satinado.

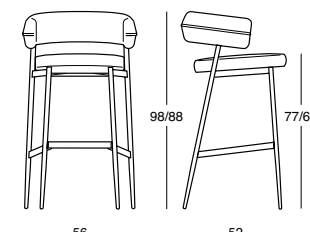

Struttura/Frame/Structure/ Gestell/Estructura





Design

Roberto Barbieri

2007

Sedia impilabile

Struttura in lega di alluminio lucidato oppure verniciato colore talco, grafite o nero. Sedile e schienale imbottiti in poliuretano. Rivestimento sfilabile in stoffa o in pelle oppure non sfilabile in cuoio. A richiesta viene fornita una fodera coprisedia da calzare senza fissare: in tessuto 100% cotone, colore bianco, disponibile sia corta che ricopre sedile e schienale, sia lunga che ricopre anche le gambe. A richiesta è disponibile un carrello per il trasporto delle sedie impilate (massimo 15 sedie).

Stackable chair

Aluminum alloy frame, polished or painted talc, graphite or black. Seat and back upholstered in polyurethane. Removable cover in fabric or leather or non-removable in cowhide. Upon request one loose cover to be put on without fixing can be supplied: in 100% white cotton, available either short covering seat and backrest or long covering legs too. Upon request a trolley for carrying the stacked chairs (max 15 chairs) is available.

Chaise superposable

Structure en alliage d'aluminium poli ou verni, couleur talc, graphite ou noir. Siège et dossier rembourrés en polyuréthane. Revêtement déhoussable en tissu ou en cuir ou pas déhoussable en cuir sellier. Sur demande on peut fournir une housse à poser sans la fixer pour protéger les chaises: en tissu 100% coton, couleur blanche, dans les versions courte qui couvre assise et dossier ou longue qui couvre même les pieds. Sur demande est disponible aussi un chariot pour déplacer les chaises superposées (maximum 15 chaises).

Stapelbarer Stuhl

Gestell aus polierter Aluminiumlegierung oder Talkum, Graphit oder schwarz lackiert. Sitz und Rückenlehne Polyurethan-gepolstert. Abnehmbarer Bezug aus Stoff oder Leder oder aus nicht abnehmbarem Kernleder. Auf Nachfrage ist ein loser Bezug verfügbar, der auf dem Stuhl ohne befestigen anzuziehen ist: aus 100% weißer Baumwolle, in zwei Versionen lieferbar, kurz, der Sitz und Rücken überzieht, oder lang, der auch die Beine überzieht. Auf Nachfrage ist ein Wagen zum Transport der gestapelten Stühle (max 15 Stühle) lieferbar.

Silla apilable

Estructura de aleación de aluminio pulido o pintado de color talco, grafito o negro. Asiento y respaldo acolchados en poliuretano. Tapizado desenfundable de tejido o de piel o no desenfundable de cuero. A pedido suministramos una funda de poner sobre la silla sin fijarla: de tejido 100% algodón, color blanco, disponible corta que cubre asiento y respaldo o larga que cubre también las patas. A pedido suministramos un carro para transportar las sillas apiladas (máximo 15 sillas).

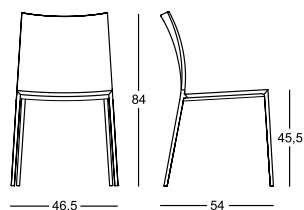

Struttura/Frame/Structure/ Gestell/Estructura



Design

Enzo Mari

1985

Sedia

Struttura in lega di alluminio lucidato o verniciato nero. Sedile e schienale in polipropilene ricoperto in cuoio 95 nei colori della cartella.

Chair

Polished or black painted aluminum alloy frame. Seat and back in polypropylene covered in cowhide 95 in the colours indicated on our colour card.

Chaise

Structure en alliage d'aluminium poli ou verni noir. Assise et dossier en polypropylène recouverts en cuir sellier 95 dans les couleurs de la fiche.

Stuhl

Gestell aus polierter oder schwarz lackierter Aluminiumlegierung. Sitzfläche und Rückenlehne aus Polypropylen mit Kernleder 95 bezogen in den Farben der Musterkarte.

Silla

Estructura de aleación de aluminio pulido o pintado negro. Asiento y respaldo de polipropileno tapizado con cuero 95 en los colores del muestrario.

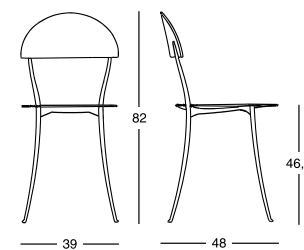

Struttura/Frame/Structure/ Gestell/Estructura



Tusa High ^{2261/A}



Design

Rodolfo Dordoni

2019

Poltroncina con schienale alto

Gambe in acciaio verniciato colore nero. Sedile in multistrato con imbottitura in poliuretano. Struttura schienale in acciaio con imbottitura in poliuretano. Rivestimento sfilabile in stoffa o in pelle. Disponibile anche la versione con sedile in pelle 95 e schienale in tessuto cat. 30.

Armchair with high backrest

Legs in black painted steel. Plywood seat upholstered with polyurethane. Steel backrest with polyurethane upholstery. Removable fabric or leather cover. The version with leather 95 covered seat cushion and backrest in fabric cat. 30 is also available.

Fauteuil avec dossier haut

Pieds en acier verni noir. Assise en contreplaqué et rembourrée en polyuréthane. Structure du dossier en acier avec rembourrage en polyuréthane. Revêtement déhoussable en tissu ou en cuir. La version avec siège revêtu en cuir 95 et dossier en tissu cat. 30 est aussi disponible.

Sessel mit hoher Rückenlehne

Beine aus schwarz lackiertem Stahl. Sitz aus Sperrholz mit Polsterung aus Polyurethan. Rückenlehne aus Stahl mit Polsterung aus Polyurethan. Abnehmbarer Bezug aus Stoff oder Leder. Die Ausführung mit Sitzkissen aus Leder 95 und Rückenlehne mit Stoff Kat. 30 ist auch verfügbar.

Butaquita con respaldo alto

Patas de acero pintado negro. Asiento en contrachapado y acolchado con poliuretano. Estructura del respaldo en acero acolchado de poliuretano. Tapizado desenfundable de tejido o de piel. Existe también una versión con asiento en piel 95 y respaldo en tejido cat. 30.

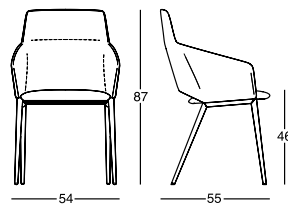

Tusa Low ^{2261/B}



Design

Rodolfo Dordoni

2019

Poltroncina con schienale basso

Gambe in acciaio verniciato colore nero. Sedile in multistrato con imbottitura in poliuretano. Struttura schienale in acciaio con imbottitura in poliuretano. Rivestimento sfilabile in stoffa o in pelle. Disponibile anche la versione con sedile in pelle 95 e schienale in tessuto cat. 30.

Armchair with low backrest

Legs in black painted steel. Plywood seat upholstered with polyurethane. Steel backrest with polyurethane upholstery. Removable fabric or leather cover. The version with leather 95 covered seat cushion and backrest in fabric cat. 30 is also available.

Fauteuil avec dossier bas

Pieds en acier verni noir. Assise en contreplaqué et rembourrée en polyuréthane. Structure du dossier en acier avec rembourrage en polyuréthane. Revêtement déhoussable en tissu ou en cuir. La version avec siège revêtu en cuir 95 et dossier en tissu cat. 30 est aussi disponible.

Sessel mit niedriger Rückenlehne

Beine aus schwarz lackiertem Stahl. Sitz aus Sperrholz mit Polsterung aus Polyurethan. Rückenlehne aus Stahl mit Polsterung aus Polyurethan. Abnehmbarer Bezug aus Stoff oder Leder. Die Ausführung mit Sitzkissen aus Leder 95 und Rückenlehne mit Stoff Kat. 30 ist auch verfügbar.

Butaquita con respaldo bajo

Patas de acero pintado negro. Asiento en contrachapado y acolchado con poliuretano. Estructura del respaldo en acero acolchado de poliuretano. Tapizado desenfundable de tejido o de piel. Existe también una versión con asiento en piel 95 y respaldo en tejido cat. 30.

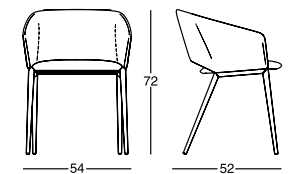

Tavoli, *consolle*,
scrivanie

Tables, *console* tables,
desks

Tables, consoles,
tables bureau

Tische, Wandtische,
Schreibtische

Mesas, *consolas*,
mesas escritorios

Ambrosiano ²³²²



Design

Mist-o

2021

Tavoli

Cavalletti in legno massello di rovere colore naturale o tinto nero a poro aperto. Piano in cristallo temperato colore fumé grigio in abbinamento al cavalletto tinto nero; oppure piano in particelle di legno placcato in rovere, disponibile nel colore naturale in abbinamento al cavalletto naturale oppure tinto poro aperto nel colore nero in abbinamento al cavalletto tinto nero; oppure piano in particelle di legno

placcato in laminato Fenix®, colore grigio chiaro o grigio antracite con bordo in rovere naturale in abbinamento al cavalletto colore naturale; oppure piano in marmo bianco di Carrara con verniciatura protettiva antimacchia, in poliestere trasparente opaco e in pietra Onsernone levigata al naturale, con trattamento olio idrorepellente antimacchia, in abbinamento ai cavalletti nel colore naturale o tinto nero.

Tables

Trestles in solid natural oak or painted black with open pore. Top available either in smoky grey tempered plate glass matching the black painted trestle; or in oak-plated particle wood, either natural matching the natural oak trestle or black painted with open pore matching the black painted trestle. Top is also available in Fenix® laminate plated particle wood in the shades light grey or anthracite grey with natural oak edge

matching the natural oak trestle; or in either white Carrara marble with stain-resistant protective varnish, in clear matt polyester or in naturally smoothed Onsernone stone, with water repellent stain-resistant oil treatment, matching the trestles in natural or black varnished oak.

Tables

Tréteaux en rouvre naturel massif ou teinté noir à pore ouvert. Plateau en verre trempé gris fumé, en combinaison avec les tréteaux vernis noirs; ou plateau en particules de bois en rouvre plaqué disponibles en couleur naturelle en combinaison avec les tréteaux naturel ou verni noir à pore ouvert en combinaison avec les tréteaux verni noir; ou plateau en particules de bois plaqué stratifié avec

laminé Fenix® gris clair ou couleur gris anthracite avec borde de rouvre naturel en combinaison avec les tréteaux de couleur naturelle; ou plateau en marbre blanc de Carrara avec peinture de protection anti taches en polyester transparent opaque, et pierre d' Onsernone, lissée naturellement, avec un traitement à l'huile hydrofuge et antitache, en combinaison avec les tréteaux de couleur naturelle ou teintés de couleur noir.

Tische

Tragböcke aus naturfarbener oder schwarz lasierter Eiche. Platte aus grau rauchfarbenem Kristallglas, passend zum schwarz lasierten Tragbock; oder Platte aus Holz-Spannplatte mit naturfarbener Eiche furniert, passend zum naturfarbenen Tragbock oder schwarz lasiert passend zum schwarz lasierten Tragbock. Auch lieferbar ist die Platte aus Holz-Spannplatte furniert mit Fenix® Laminat, entweder

in den Farben hellgrau oder Anthrazit-grau, mit Rand aus naturfarbener Eiche passend zum naturfarbenen Tragbock; oder Platte entweder aus weißem Carrara-Marmor mit Fleckenschutz Lackierung aus klarem mattem Polyester oder aus Onsernone-Stein, naturgeschliffen mit wasserabweisendem, Fleckenschutz Öl behandelt, passend zu den Tragböcken aus naturfarbener oder schwarz lasierter Eiche.

Mesas

Caballetes de roble macizo barnizado de color natural o teñido negro a poro abierto. Superficie de cristal templado, color gris humo, combinado con los caballetes teñidos negro; o superficie de aglomerado de madera aplacado en roble, disponible barnizado en color natural combinado con los caballetes barnizado color natural o teñidos a poro abierto en color negro combinado con los caballetes teñidos negro; o superficie de aglomerado

de madera aplacado con laminado Fénix®, de color gris claro o color gris antracita con borde de roble natural combinado con los caballetes barnizados de color natural; o superficie de mármol blanco de Carrara con laca de protección antimancha en poliéster opaco transparente, y piedra Onsernone pulida natural, con tratamiento de aceite repelente al agua antimancha, combinados con los caballetes barnizados en color natural o teñidos negro.

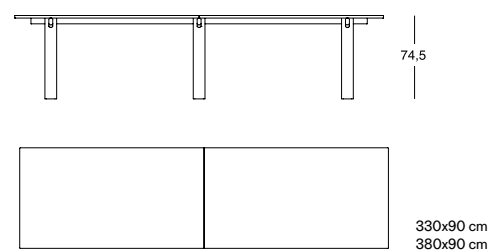
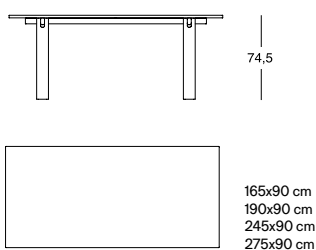

Struttura/Frame/Structure/Gestell/Estructura

Rovere naturale/
Natural
oakwood/
Rouvre naturel/
Naturfarbene
Eiche/Roble
natural



Rovere tinto
nero/Black
varnished oak/
Rouvre teinté
noir/Schwarz-
gebeizte Eiche/
Roble teñido
negro



Piano/Top/Plateau/Platte/Sobre

Cristallo fumé
grigio/Smoky
grey plate glass/
Verre gris fumé/
Rauchfarbenedes
Kristallglas/
Cristal gris humo



Rovere naturale/
Natural
oakwood/
Rouvre naturel/
Naturfarbene
Eiche/Roble
natural



Rovere tinto
nero/Black
varnished oak/
Rouvre teinté
noir/Schwarz-
gebeizte Eiche/
Roble teñido
negro



Laminato Fenix® /
Fenix® laminate/
Laminé Fenix® /
Fenix® Laminat/
Laminado Fenix®



Marmo di
Carrara/Carrara
marble/Marbre
de Carrare/
Carrara Marmor/
Mármol de
Carrara



Pietra
Onsernone/
Onsernone
stone/Pierre
Onsernone/
Onsernone
Stein/Piedra
Onsernone





Design

Zaven

2023

Tavolo

Basi in poliuretano rigido laccate opaco colore talco, canapa, caramello, alga, amaranto, espresso e nero o laccate lucide in colore talco, canapa e nero, oppure metallizzate colore caramello, alga, amaranto e espresso,

in abbinamento a piani in MDF nei medesimi colori laccati opachi talco, canapa, caramello, alga, amaranto, espresso e nero.

Table

Hard polyurethane bases matt lacquered in the shades talc, hemp, caramel, algae, amaranth, espresso and black or glossy lacquered in the shades talc, hemp and black, or with metallic finish in the shades caramel, algae,

amaranth and espresso, in combination with MDF tops in the same matt lacquered colours talc, hemp, caramel, algae, amaranth, espresso and black.

Table

Bases en polyuréthane rigide laqué mat dans les couleurs talc, chanvre, caramel, algues, rouge amarante, espresso ou noir ou laqué brillant dans les couleurs talc, chanvre et noir, ou métallisé dans les couleurs caramel,

algues, rouge amarante et espresso en combinaison avec des plateaux en MDF dans les mêmes couleurs laquées mat talc, chanvre, caramel, algues, rouge amarante, espresso et noir.

Tisch

Untergestelle aus hartem Polyurethan, matt lackiert in den Farben Talkum, Hanf, Karamell, Algen, Amaranthrot, Espresso und schwarz oder glänzend lackiert in den Farben Talkum, Hanf und schwarz, oder mit

Metallic Finish in den Farben Karamell, Algen, Amaranthrot und Espresso in Kombination mit MDF-Platten in den gleichen matt lackierten Farben Talkum, Hanf, Karamell, Algen, Amaranthrot, Espresso und schwarz.

Mesa

Bases de poliuretano rígido lacado mate en colores talco, cañamo, caramelo, alga, granate, espresso y negro, o lacado brillante en colores talco, cañamo y negro, o metalizado en los colores caramelo, alga, granate y

espresso, en combinación con sobres de MDF en los mismos colores lacado mate talco, cañamo, caramelo, alga, granate, espresso y negro.

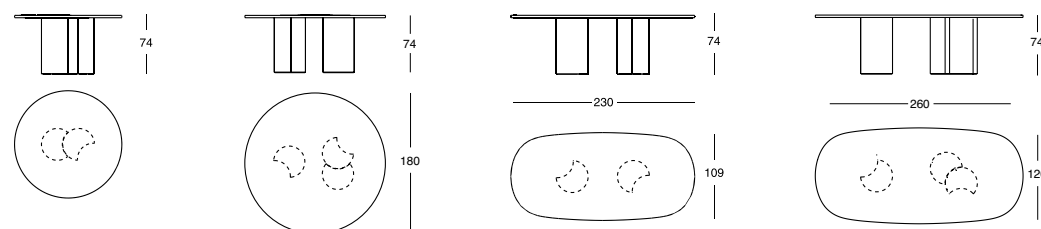

Dimensioni/Sizes/
Dimensions/
Abmessungen/
Medidas

Ø 135 cm
Ø 160 cm
Ø 180 cm
230x109 cm
260x120 cm

Talco opaco /Matt talc/Talc mat/ Talkum matt/Talco mate	Canapa opaco/ Matt hemp/ Chanvre mat/Hanf mat/Cañamo mate	Caramello opaco/ Matt caramel/ Caramel mat/ Karamell matt/ Caramelo mate	Alga opaco/Matt algae/Algues mat/ Algen matt/Alga mate	Amaranto opaco/ Matt amaranth/ Rouge amarante mat/Amaranthrot matt/Granate mate	Espresso opaco/ Matt espresso/ Espresso mat/ Espresso mate	Nero opaco /Matt black/Noir mat/ Schwarz matt/ Negro mate	
Talco lucido/ Glossy talc/Talc brillant/Talkum glänzend/Talco brillante	Canapa lucido/ Glossy hemp/ Chanvre brillant/ Hanf glänzend/ Cañamo brillante	Nero lucido/ Glossy black /Noir brillant/Schwarz glänzend/Negro brillante		Caramello metallizzato/Caramel metallic/Caramel métallisé/Metallic-Karamell/Caramelo metalizado	Alga metallizzato/ Algae metallic/ Algues métallisé/ Metallic-Algen/ Alga metalizado	Amaranto metallizzato/Amaranth metallic/ Rouge amarante métallisé/Metallic-Amaranthrot/Granate metalizado	Espresso metallizzato/Espresso metallic/ Espresso métallisé/ Metallic-Espresso / Espresso metalizado



Design

Zaven

2023

Tavolo

Basi in poliuretano rigido laccate opaco colore talco, canapa, caramello, alga, amaranto, espresso e nero o laccate lucide colore talco, canapa e nero, oppure metallizzate colore caramello, alga, amaranto e espresso in abbinamento a piani in MDF nei medesimi

colori laccati opachi talco, canapa, caramello, alga, amaranto, espresso e nero con inserimento di piano in cristallo extra light, temperato, retro verniciato nello stesso colore.

Table

Hard polyurethane bases matt lacquered in the shades talc, hemp, caramel, algae, amaranth, espresso and black or glossy lacquered in the shades talc, hemp and black, or with metallic finish in the shades caramel, algae, amaranth and espresso, in combination with MDF tops

in the same matt lacquered colours talc, hemp, caramel, algae, amaranth, espresso and black with inclusion of extra light glass top, tempered, back painted in the same color.

Table

Bases en polyuréthane rigide laqué mat dans les couleurs talc, chanvre, caramel, algues, rouge amarante, espresso et noir ou laqué brillant dans les couleurs talc, chanvre et noir, ou métallisé dans les couleurs caramel, algues, rouge amarante et espresso en combinaison

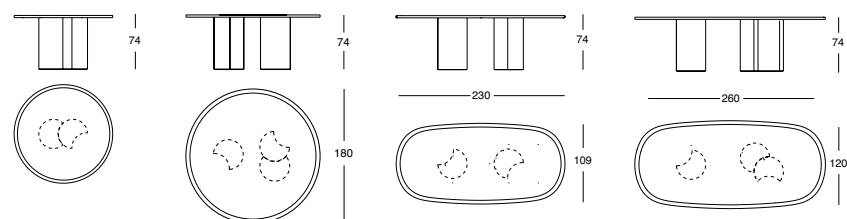

Dimensioni/
Sizes/
Dimensions/
Abmessungen/
Medidas

Ø 135 cm
Ø 160 cm
Ø 180 cm
230x109 cm
260x120 cm

avec des plateaux en MDF dans les mêmes couleurs laquées mat talc, chanvre, caramel, algues, rouge amarante, espresso et noir avec insertion de plateau en cristal extra light, trempé, dos peint dans la même couleur.

Tisch

Untergestelle aus hartem Polyurethan, matt lackiert in den Farben Talkum, Hanf, Karamell, Algen, Amarantröt, Espresso und schwarz oder glänzend lackiert in den Farben Talkum, Hanf und schwarz, oder mit Metallic Finish in den Farben Karamell, Algen, Amarantröt

und Espresso in Kombination mit MDF-Platten in den gleichen matt lackierten Farben Talkum, Hanf, Karamell, Algen, Amarantröt, Espresso und schwarz mit dem Einsatz einer extra leichten, gehärteten Glasplatte, die in der gleichen Farbe nach hinten lackiert ist.

Mesa

Bases de poliuretano rígido lacado mate en colores talco, cañamo, caramelo, alga, granate, espresso y negro, o lacado brillante en colores talco, cañamo y negro, o metalizado en los colores caramelo, alga, granate y espresso, en combinación con sobres de

MDF en los mismos colores lacado mate talco, cañamo, caramelo, alga, granate, espresso y negro con la inserción de un sobre de cristal templado extra claro, en la parte trasera lacado en el mismo color.

Talco opaco /Matt talc/Talc mat/Talkum matt/Talco mate	Canapa opaco/Matt hemp/Chanvre mat/Hanf matt/Cañamo mate	Caramello opaco/Matt caramel/Caramel mat/Karamell matt/Caramelo mate	Alga opaco/Matt algae/Algues mat/Algen matt/Alga mate	Amaranto opaco/Matt amaranth/Rouge amarante mat/Amarantröt matt/Granate mate	Espresso opaco/Matt espresso/Espresso mat/Espresso mate	Nero opaco /Matt black/Noir matt/Schwarz matt/Negro mate	
○	●	●	●	●	●	●	
Talco lucido/Glossy talc/Talc brillant/Talkum glänzend/Talco brillante	Canapa lucido/Glossy hemp/Chanvre brillant/Hanf glänzend/Cañamo brillante	Nero lucido/Glossy black/Noir brillant/Schwarz glänzend/Negro brillante		Caramello metallizzato/Caramel metallisé/Metallic-Karamell/Caramelo metalizado	Alga metallizzato/Algae metallic/Algues métallisé/Metallic-Algen/Alga metalizado	Amaranto metallizzato/Amaranth metallisé/Rouge amarante métallisé/Metallic-Amarantröt/Granate metalizado	Espresso metallizzato/Espresso metallisé/Espresso metalizado
○	●	●		●	●	●	●

Lazy Susan ²³²⁷

NEW PRODUCT



Piatto da tavola girevole
Base girevole su sfere metalliche. Piano in MDF laccato opaco colore talco, canapa, caramello, alga, amaranto, espresso o nero.

Revolving table plate
Swivel base on metal spheres. Matt lacquered MDF top in talc, hemp, caramel, algae, amaranth, espresso or black.

Plateau de table rotatif
Base pivotante sur sphères en métal. Plateau en MDF laqué mat en talc, chanvre, caramel, algue, rouge amarante, espresso ou noir.

Drehbare Tischplatte
Drehbarer Fuß auf Metallkugeln. Matt lackierte MDF-Platte in Talkum, Hanf, Karamell, Algen, Amaranthrot, Espresso oder schwarz.

Plato de mesa giratoria
Base giratoria sobre esferas metálicas. Tablero de MDF lacado mate en talco, cáñamo, caramelo, alga, granate, espresso o negro.

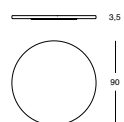

Calamo ²⁷³⁰

NEW FINISHES



Design

Gabriele Rosa

2013

Scrivania
Struttura e piano in acciaio verniciato colore talco, grafite o nero. Piano e vano portaoggetti in cuoio pigmentato 90. Il vano è accessibile mediante apertura a ribalta.

Desk
Varnished steel frame and top in talc, graphite or black. Top and storage space in cowhide pigmentato 90. The storage space is accessed by a drop-leaf opening.

Table bureau
Structure et plateau en acier verni couleur talc, graphite ou noire. Plateau et élément porte-objets en cuir sellier pigmentato 90. L'élément est accessible par une ouverture basculante.

Schreibtisch
Gestell und Platte aus Talkum-graphitfarben oder schwarz lackiertem Stahl. Platte und Ablagefach aus Kernleder pigmentato 90. Das Ablagefach ist mit Kippöffnung versehen.

Escritorio
Estructura y sobre de acero barnizado color talco, grafito o negro. Sobre y compartimento portaobjetos de cuero pigmentato 90. Se puede acceder al compartimento mediante apertura abatible.

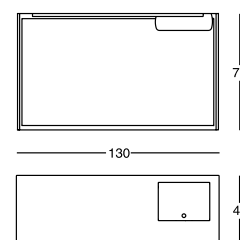

Struttura/Frame/Structure/Gestell/Estructura



Cavour CM ²⁶⁹⁰



Omaggio a

Carlo Mollino

1949

Tavolo scrivania

Gambe in legno massello di rovere naturale o tinto nero, oppure in legno massello di noce Canaletto; verniciatura con finitura a cera. Cassetteria e piano estraibile impiallacciati in rovere naturale o tinto nero, oppure in noce Canaletto, verniciatura con finitura a cera, entrambi rivestiti con cristallo temperato, extra-chiaro, retro-verniciato nero. Piano in cristallo trasparente o extra-chiaro, oppure cristallo fumé grigio, in

abbinamento alla struttura in rovere tinto nero. A richiesta è disponibile un Executive kit che prevede il rivestimento in cuoio nero del fondo del piano estraibile e del primo cassetto della cassetteria, un sottomano in cuoio nero e un portapenna in legno massello realizzato nelle medesime finiture della scrivania.

Writing desk

Legs in solid natural or black varnished oak, or in solid Canaletto walnut; wax-finished varnish. Extractable open tray and drawer element veneered in natural or black varnished oak, or in Canaletto walnut, wax-finished varnish, both covered with extra-clear tempered plate glass, back-painted in black. Clear or extra clear plate glass top, or smoky grey plate glass top, matching the black oak frame. Upon request an

Executive kit is available, including the bottom of the extractable open tray and the first drawer covered with black cowhide, one desk pad in black cowhide and one penholder in solid wood, made in the same finishes as the writing desk.

Table bureau

Pieds en rouvre naturel massif ou teinté noir ou en noyer Canaletto massif; verni finition cirée. Bloque tiroirs et plateau coulissant plaqués en rouvre naturel ou teinté noir, ou en noyer Canaletto, verni finition cirée, les deux recouverts en verre trempée, extra clair, dos-vernir noir. Plateau en verre extra clair ou transparent, ou en verre gris fumé, en combinaison avec la structure en rouvre teinté noir. Sur demande il est disponible un Executive

kit pour recouvrir en cuir sellier noir le fond du plateau coulissant et du premier tiroir du caisson, un sous-main en cuir sellier noir et pot à crayons en bois massif réalisé dans les mêmes finitions du bureau.

Schreibtisch

Beine aus massiver naturfarbener oder schwarz gebeizter Eiche, oder aus massivem Nussbaum Canaletto; Lackierung mit Wachs-Endbehandlung. Ausziehbares offenes Tablett und Schublade furniert mit naturfarbener oder schwarz gebeizter Eiche, oder mit Nussbaum Canaletto; Lackierung mit Wachs-Endbehandlung. Beide sind bezogen mit extra-klarem gehärtetem und nach hinten schwarz lackiertem Kristallglas.

Tischplatte aus transparentem oder extra-klarem Kristallglas, oder aus grau rauchfarbenem Kristallglas, passend zum Gestell aus schwarz gebeizter Eiche. Auf Nachfrage ist ein Executive Kit verfügbar, das den Bodenbezug des ausziehbaren offenen Tablettes und der ersten Schubladen aus schwarzem Kernleder, sowie eine Schreibunterlage aus schwarzem Kernleder, und einen Holzstifthalter in den gleichen Ausführungen des Schreibtisches enthält.

Mesa escritorio

Patas de madera maciza de roble natural o teñido negro o de nogal Canaletto macizo; pintura con acabado de cera. Cajonera y top extraíble contrachapados de roble natural o teñido negro, o de nogal Canaletto, pintura con acabado de cera, ambos tapizados de cristal templado extra claro, parte trasera pintada negra. Superficie de cristal transparente o extra claro, o de cristal gris humo, combinado con la estructura de roble teñido negro. Sobre pedido es disponible un

Executive kit para tapizar de cuero negro el fondo del top extraíble y del primero cajón de la cajonera, un deskpap de cuero negro y un portalápiz de madera maciza realizado en los mismos acabados del escritorio.

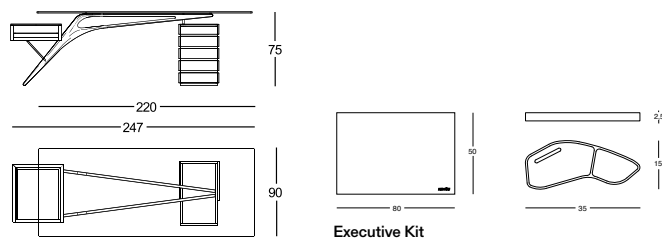

Struttura/Frame/Structure/Gestell/Estructura

Rovere naturale/
Natural
oakwood/
Rouvre naturel/
Naturfarbene
Eiche/Roble
natural



Rovere tinto nero/
Black varnished
oak/Rouvre teinté
noir/Schwarz-
gebeizte Eiche/
Roble teñido
negro



Noce Canaletto/
Canaletto walnut/
Noyer Canaletto/
Nussbaum
Canaletto/Nogal
Canaletto



Piano/Top/Plateau/Platte/Sobre

Cristallo trasparente/Transparent plate
glass/Verre transparent/Transparentes
Kristallglas/Cristal transparente



Cristallo extra-chiaro/Extra-clear plate
glass/Verre extra-clair/Extra-klares
Kristallglas/Cristal extra-claro



Cristallo fumé grigio/Smoky grey plate
glass/Verre gris fumé/Rauchfarbenes
Kristallglas/Cristal gris humo





Design

Piero Bottoni

1930

Scrivania
Struttura in tubo di acciaio inox. Piano e cassetiera verniciati goffrati antigraffio nei colori talco o nero. Il piano

può essere con inserto in cuoio pigmentato.

Writing desk
Stainless steel tubular frame. Top and drawer unit finished with scratch resistant embossing in the colours talc

or black. The top can be with cowhide pigmentato insert.

Table bureau
Structure en tube d'acier inox. Plateau et caisson vernis anti-rayures dans les couleurs talc ou noire. Le

plateau peut être avec finition en cuir sellier pigmentato.

Schreibtisch
Gestell aus Inox-Stahl-Rohr. Platte und Schubladen mit kratzfester Lackierung in den Farben Talkum oder

schwarz. Die Platte ist auch mit eingelegtem Kernleder pigmentato.

Mesa escritorio
Estructura en tubo de acero inox. Sobre y cajonera lacados con relieve antirasguño en los colores

talco o negro. El sobre puede ser también con inserción de cuero pigmentato.

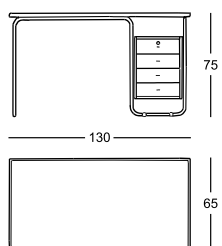

Fenice²⁵⁷⁴



Design

Piero Bottoni

1936

Tavolo

Esemplare numerato. Struttura in Polimex®, rivestita in cemento con finitura acrilica e trattamento di protezione nano tecnologico antimacchia a base di biossido di titanio, colore grigio.

Table

Numbered piece. Frame in Polimex®, covered with acrylic finish cement with protective titanium dioxide nanotech stain-resistant treatment, in the shade of grey.

Table

Exemplaire énuméré. Structure en Polimex®, revêtu en ciment avec finition acrylique et traitement de protection nano technologique anti-tâche à base de bioxyde de titane, couleur gris.

Tisch

Nummeriertes Exemplar. Gestell aus Polimex®, mit Zement verkleidet, mit Akrylfinish und nanotechnologischer Fleckenschutzbehandlung mit Titandioxid, in der Farbe grau.

Mesa

Pieza numerada. Estructura de Polimex®, revestido en cemento con acabado acrílico y tratamiento de protección nanotecnológico antimancha a base de dióxido de titanio, color gris.

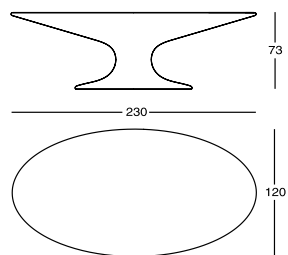

Leonardo²⁶⁵⁰



Design

Achille Castiglioni

1969

Tavolo da lavoro

Struttura in faggio evaporato, colore naturale. Piano placcato in laminato colore bianco, oppure in cristallo temperato. Regolabile in altezza.

Working table

Natural varnished steam-treated beech trestle. Top coated with white plastic laminate, or with tempered plate glass. Adjustable height.

Table de travail

Structure en hêtre évaporé, couleur naturelle. Plateau plaqué en laminé plastique, couleur blanche, ou en verre trempé. Hauteur réglable.

Arbeitstisch

Tragböcke aus gedampfter Buche, naturfarben. Platte mit weißem Schichtpreßstoff Laminat beschichtet, oder aus hitzebeständigem Kristallglas. Höhenverstellbar.

Mesa de trabajo

Estructura de haya vaporizada, color natural. Sobre aplacado con laminado, color blanco o de cristal templado. Altura regulable.

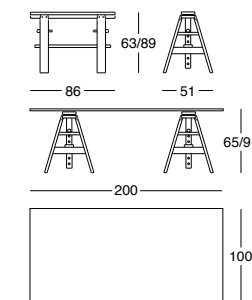

Piano/Top/Plateau/Platte/Sobre

Cristallo/Glass/Verre/Kristallglas/Cristal

Laminato/Laminat/Laminé/Laminat/Laminado



Marcuso ²⁵³⁰

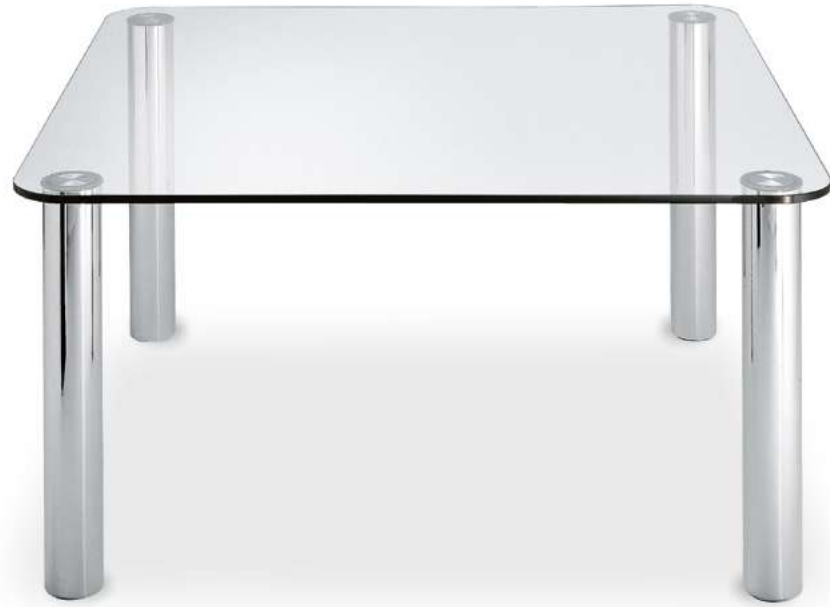

Design

Marco Zanuso

1969

Tavolo
Piano in cristallo trasparente.
Gambe in acciaio inox.

Table
Clear plate glass top.
Stainless steel legs.

Table
Plateau en verre transparent.
Pieds en acier.

Tisch
Platte aus klarem Kristallglas.
Beine aus Inox Stahl.

Mesa
Sobre de cristal transparente.
Patas de acero inox.

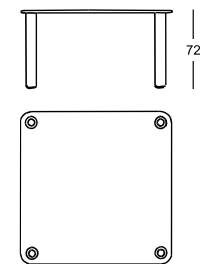

Dimensioni/Sizes/Dimensions/
Abmessungen/Medidas

100x100 cm
140x140 cm
90x200 cm

Orione ²³³⁷



Design

Roberto Barbieri

1996

Tavolo
Piano in cristallo. Struttura
in rovere naturale oppure
in rovere tinto nero, con
tiranti in acciaio nichelato e
spazzolato.

Table
Plate glass top. Frame
in natural oak or in black
varnished oak, with brushed
and nickel satin finished steel
tie-rods.

Table
Plateau en verre. Structure
en rouvre naturel, ou en
rouvre teinté noir avec tirants
en acier niquelé et brossé.

Tisch
Platte aus Kristallglas. Gestell
aus naturfarbener oder
schwarz gebeizter Eiche, mit
Streben aus vernickeltem
und gebürstetem Stahl.

Mesa
Superficie de cristal.
Estructura de roble natural
o de roble teñido negro, con
tirantes de acero niquelado y
cepillado.

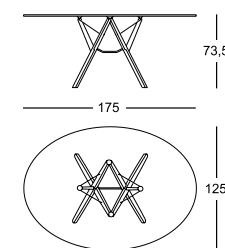

Dimensioni/Sizes/Dimensions/
Abmessungen/Medidas

Ø 125 cm
Ø 135 cm
125x175 cm

Struttura/Frame/Structure/Gestell/Estructura

Rovere naturale/Natural oakwood/
Rouvre naturel/Naturfarbene Eiche/
Roble natural

Rovere tinto nero/Black varnished oak/
Rouvre teinté noir/Schwarz-gebeizte
Eiche/Roble teñido negro



Poker²⁶²⁵



Design

Joe Colombo

1968

Tavolo da gioco

Piani in laminato plastico stratificato, colore bianco. Panno verde con bordo in pelle, amovibile. Gambe in acciaio inox.

Card table

Tops in white layered plastic laminate. Removable, leather trimmed green baize. Stainless steel legs.

Table de jeu

Plateaux en laminé plastique stratifié, couleur blanche. Tapis vert avec bords en cuir, amovible. Pieds en acier inox.

Spieltisch

Tischplatten aus massivem Schichtpreßstoff Laminat, weißfarben. Grünes Filztuch mit Lederrand, abnehmbar. Beine aus Inox-Stahl.

Mesa de juego

Sobres de laminado plástico estratificado, color blanco. Tapete verde extraíble con borde de piel. Patas de acero inox.

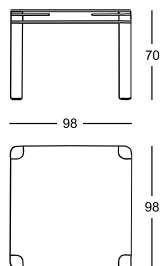

Quaderna Table²⁶⁰⁰



Design

Superstudio

1969-1972

Tavolo/tavolo scrivania

Struttura in legno tamburato placcato in laminato Print, colore bianco, a stampa digitale a quadretti neri con interasse di 3 cm.

Table/writing desk

Honeycomb core structure coated with white plastic laminate, digitally printed with black squares at 3 cm spacing.

Table/table bureau

Structure en panneau alvéolaire plaqué en Print, couleur blanche, imprimé en digital à carrés noirs avec entraxe de 3 cm.

Tisch/Schreibtisch

Gestell aus Sperrholz mit weißem Print belegt. Digitaldruck mit kariertem Muster, Linienabstand 3 cm.

Mesa/mesa escritorio

Estructura de madera enchapada aplacada con laminado Print, color blanco, a impresión digital en cuadritos negros de 3 cm.

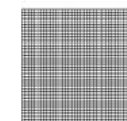
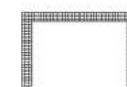

Dimensioni/Sizes/Dimensions/
Abmessungen/Medidas

111x111 cm
126x126 cm
90x180 cm

Quaderna Desk ²⁸³⁰

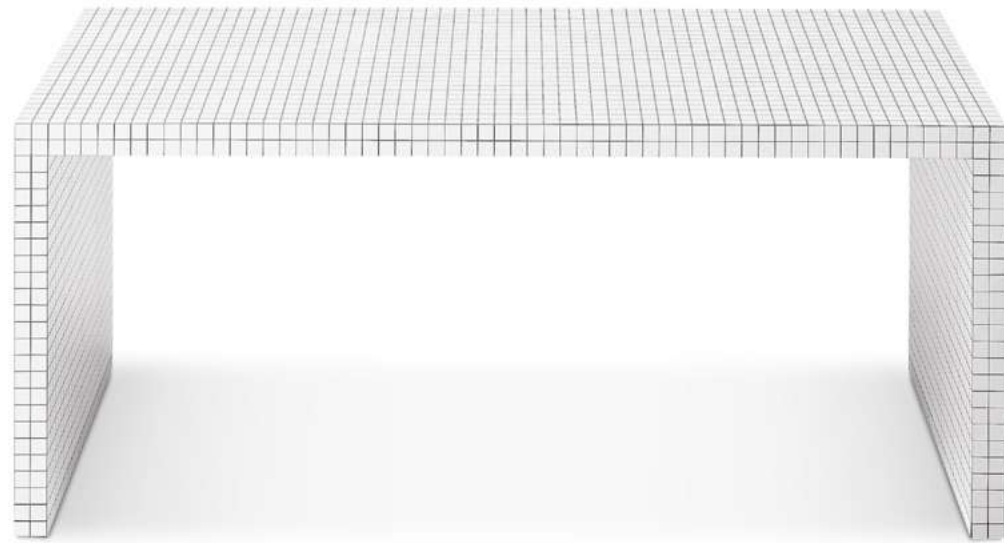

Quaderna Writing Desk ²⁷⁵⁰

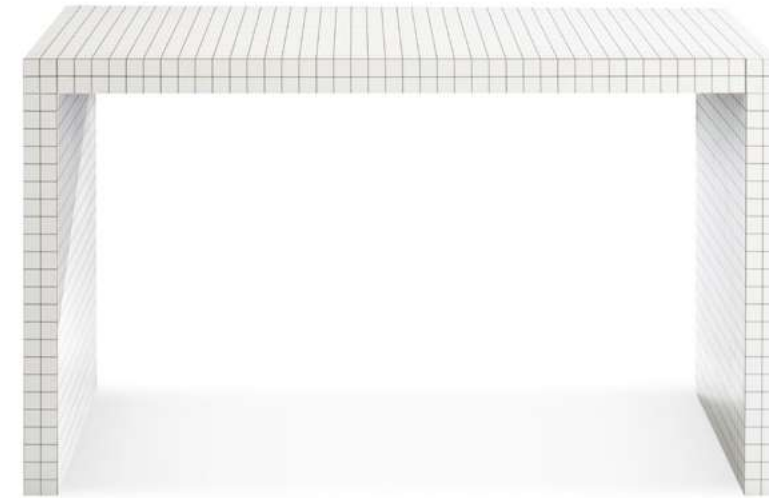

Design

Superstudio

1969-1972

Tavolo/tavolo scrivania
Struttura in legno tamburato placcato in laminato Print, colore bianco, a stampa digitale a quadretti neri con interasse di 3 cm.

Table/writing desk
Honeycomb core structure coated with white plastic laminate, digitally printed with black squares at 3 cm spacing.

Table/table bureau
Structure en panneau alvéolaire plaqué en Print, couleur blanche, imprimé en digital à carrés noirs avec entraxe de 3 cm.

Tisch/Schreibtisch
Gestell aus Sperrholz mit weißem Print belegt. Digitaldruck mit kariertem Muster, Linienabstand 3 cm.

Mesa/mesa escritorio
Estructura de madera enchapada aplacada con laminado Print, color blanco, a impresión digital en cuadritos negros de 3 cm.

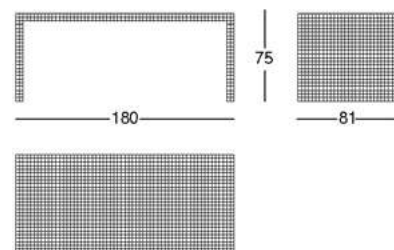

Design

Superstudio

1969-1972

Scrittoio
Struttura in legno tamburato placcato laminato Print, colore bianco, a stampa digitale a quadretti con interasse di 3 cm. Cassetto estraibile a scomparsa ricavato nello spessore del piano, vano cassetto in legno verniciato goffrato antigraffio colore nero.

Desk
Honeycomb core structure coated with white Print laminate, digitally printed with black squares at 3 cm spacing. The top hides a retractable pull-out drawer, with a drawer compartment in black scratch-resistant embossed painted wood.

Bureau
Structure en panneau alvéolaire plaqué en laminé Print, couleur blanche, imprimé en digital à carrés noirs avec entraxe de 3 cm. Tiroir rétractable obtenu dans l'épaisseur du dessus du plateau; compartiment intérieur du tiroir en bois verni gaufré noir résistant aux rayures.

Schreibtisch
Gestell aus Sperrholz mit weißem Print Laminat belegt. Digitaldruck mit kariertem Muster, Linienabstand 3 cm. Eine einziehbare Schublade befindet sich in dem Dicken der Oberplatte mit Schubladenfach aus schwarz kratzfestem und lackiertem Holz.

Escritorio
Estructura de madera aplacada con laminado Print, color blanco, a impresión digital en cuadritos negros de 3 cm. Cajón retráctil obtenido en el grosor de la parte superior; compartimento del cajón en madera pintada en relieve antirasguño, color negro.

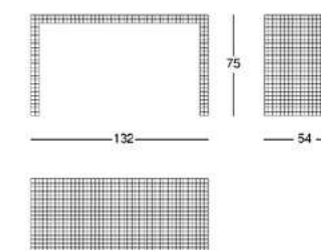

Quaderna Consolle ⁷¹⁰

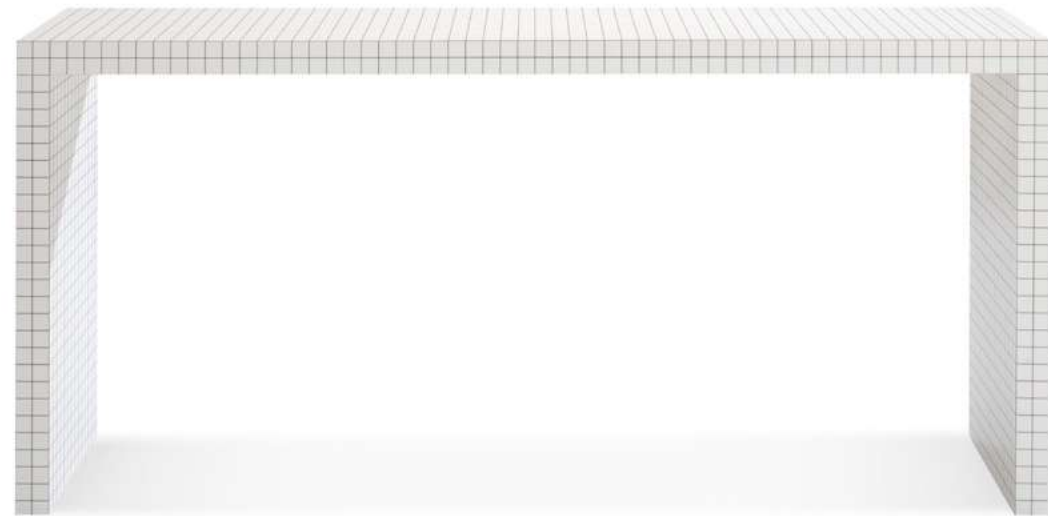

Design

Superstudio

1969-1972

Consolle

Struttura in legno tamburato placcato in laminato Print, colore bianco, a stampa digitale a quadretti neri con interasse di 3 cm.

Console table

Honeycomb core structure coated with white plastic laminate, digitally printed with black squares at 3 cm spacing.

Console

Structure en panneau alvéolaire plaqué en Print, couleur blanche, imprimé en digital à carrés noirs avec entraxe de 3 cm.

Wandtisch

Gestell aus Sperrholz mit weißem Print belegt. Digitaldruck mit kariertem Muster, Linienabstand 3 cm.

Consola

Estructura de madera aplacada con laminado Print, color blanco, a impresión digital en cuadritos negros de 3 cm.

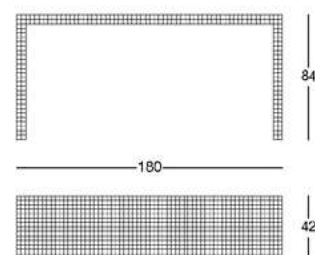

Reale ²³²⁰

NEW FINISHES



Omaggio a

Carlo Mollino

1948

Tavolo

Piano in cristallo trasparente con o senza bordi bisellati, oppure in marmo Emperador, con verniciatura protettiva antimacchia in poliester trasparente opaco. Struttura in legno massello di rovere naturale o tinto noce Canaletto, oppure tinto arancione o nero; verniciatura con finitura a cera.

Table

Clear plate glass top, with or without bevelled edges or in Emperador marble, with stain-resistant protective varnish, in clear matt polyester. Frame in solid natural or orange or black varnished oak, or in Canaletto walnut-dyed oak; wax-finished varnish.

Table

Plateau en verre transparent avec ou sans bords biseautés, ou en marbre Emperador, avec vernis de protection anti-taches en polyester transparent mat. Structure en rouvre naturel massif ou teinté orange ou noir, ou en rouvre teinté noyer Canaletto; verni finition cirée.

Tisch

Tischplatte aus transparentem Kristallglas mit oder ohne schräg-abgeschliffenen Rändern, oder aus Emperador Marmor, mit Fleckenschutz-Lackierung aus klarem mattem Polyester. Gestell aus massiver naturfarbener oder orange- oder schwarz-gebeizter Eiche oder aus Nussbaum Canaletto gebeizter Eiche; Lackierung mit Wachs-Endbehandlung.

Mesa

Superficie de cristal transparente con o sin borde biselado, o en mármol Emperador, con laca de protección anti mancha en poliéster transparente mate. Estructura de madera maciza de roble natural o teñido naranja o negro o de roble teñido nogal Canaletto; pintura con acabado de cera.

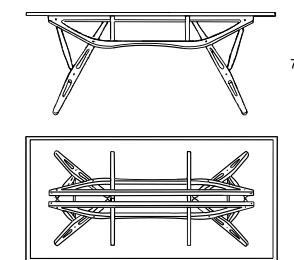

Dimensioni/Sizes/Dimensions/Abmessungen/ Medidas

80x160 cm
90x180 cm
90x200 cm

Struttura/Frame/Structure/Gestell/Estructura

Rovere naturale/
Natural oakwood/
Rouvre naturel/
Naturfarbene
Eiche/Roble
natural

Rovere tinto
arancione/
Orange varnished
oak/Rouvre teinté
orange/Orange-
gebeizte Eiche/
Roble teñido
naranja

Rovere tinto nero/
Black varnished
oak/Rouvre teinté
noir/Schwarz-
gebeizte Eiche/
Roble teñido
negro

Rovere tinto noce
Canaletto/Cana-
letto walnut dyed
oak/Rouvre teinté
noyer Canaletto/
Nussbaum
Canaletto
gebeizte Eiche/
Roble teñido nogal
Canaletto

Piano/Top/Plateau/Platte/Sobre

Cristallo
trasparente/
Transparent
plate glass/Verre
transparent/
Transparentes
Kristallglas/Cristal
transparente

Marmo
Emperador/
Emperador
marble/Marbre
Emperador/
Emperador
Marmor/Marmól
Emperador





Omaggio a

Carlo Mollino

1948

Tavolo

Struttura in legno massello di rovere naturale o tinto arancione o nero oppure in legno massello di noce Canaletto colore naturale; verniciatura con finitura a cera. Piano in cristallo extra-chiaro con bordo a

taglio inclinato, oppure in cristallo fumè grigio con bordo a taglio inclinato, in abbinamento alla struttura in rovere tinto nero.

Table

Frame in solid natural or orange or black varnished oak, or in solid natural Canaletto walnut; wax-finished varnish. Extra clear plate glass top, with inclined cut edges, or smoky grey plate glass top, with inclined

cut edges, matching the black oak frame.

Table

Structure en rouvre naturel massif ou teinté orange ou noir ou en noyer Canaletto massif, couleur naturelle; verni finition cirée. Plateau en verre extra- clair à bord coupé oblique, ou en verre gris fumé à bord coupé

oblique, en combinaison avec la structure en rouvre teinté noir.

Tisch

Gestell aus massiver naturfarbener oder orange- oder schwarz gebeizter Eiche, oder aus massivem naturfarbenem Nussbaum Canaletto. Lackierung mit Wachs-Endbehandlung. Tischplatte aus extra-klarem

Kristallglas, mit geneigten geschnittenen Rändern, oder aus grau rauchfarbenem Kristallglas mit geneigten geschnittenen Rändern, passend zu dem Gestell aus schwarz gebeizter Eiche.

Mesa

Estructura de madera maciza de roble natural o teñido naranja o negro o de madera maciza de nogal Canaletto color natural; pintura con acabado de cera. Superficie de cristal extra claro con borde de corte inclinado,

o de cristal gris humo con borde de corte inclinado, combinado con la estructura en roble teñido negro.

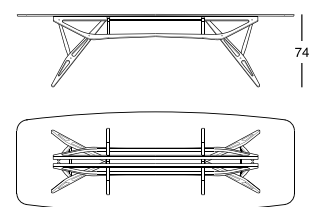

Dimensioni/Sizes/
Dimensions/
Abmessungen/
Medidas

90x220 cm
100x250 cm
100x280 cm

Struttura/Frame/Structure/Gestell/Estructura

Rovere naturale/
Natural oakwood/
Rouvre naturel/
Naturfarbene
Eiche/Roble
natural

Rovere tinto
arancione/
Orange varnished
oak/Rouvre teinté
orange/Orange-
gebeizte Eiche/
Roble teñido
naranja

Rovere tinto nero/
Black varnished
oak/Rouvre teinté
noir/Schwarz-
gebeizte Eiche/
Roble teñido
negro

Rovere tinto noce
Canaletto/Cana-
letto walnut dyed
oak/Rouvre teinté
noyer Canaletto/
Nussbaum
Canaletto
gebeizte Eiche/
Roble teñido nogal
Canaletto

Piano/Top/Plateau/Platte/Sobre

Cristallo extra-
chiaro/Extra-clear
plate glass/Verre
extra-clair/Extra-
klares Kristallglas/
Cristal extra-claro

Cristallo fumé
grigio/Smoky
grey plate glass/
Verre gris fumé/
Rauchfarbenes
Kristallglas/Cristal
gris humo





Design

Calvi Brambilla

2024

Tavolo

Piano in legno tamburato, con anima in alveolare di alluminio, impiallacciato in frassino tinto poro aperto colore alga, amaranto, espresso o nero, oppure frassino tinto rovere. Gambe in legno massello di frassino

tinto negli stessi colori del piano. È data la possibilità di scegliere il posizionamento delle gambe, se a filo del piano oppure leggermente arretrate.

Table

Honeycomb wood top, with aluminium honeycomb core, veneered with open pore stained ash in the colours algae, amaranth, espresso or black or in oak stained ash. Legs made of solid stained ash in the same colours

as the top. We offer the possibility to position the legs either flush with the top or slightly back.

Table

Plateau en bois alvéolaire, avec âme en aluminium alvéolaire, plaqué en frêne teinté à pore ouvert dans les couleurs algues, rouge amarante, espresso ou noir ou frêne teinté rouvre. Pieds en frêne massif teinté dans

les mêmes couleurs que le plateau. Il est possible de choisir la position des pieds, qu'ils soient au ras du plateau ou légèrement en retrait.

Tisch

Platte aus Sperrholz mit Aluminiumwabenkern, furniert mit offenporig gebeizter Esche in den Farben Algen, Amaranthrot, Espresso oder schwarz oder mit Eiche gebeizter Esche. Beine aus massiver

Esche, gebeizt in denselben Farben wie die Platte. Es ist möglich, die Position der Beine zu wählen, ob bündig mit der Platte oder leicht zurückgesetzt.

Mesa

Sobre de madera alveolar, con anima alveolar de aluminio, chapado en fresno teñido a poro abierto en los colores alga, granate, espresso o negro o fresno teñido roble. Patas de fresno macizo teñido en los mismos

colores del sobre. Es posible elegir la posición de las patas, a ras de el sobre o ligeramente retranqueadas.

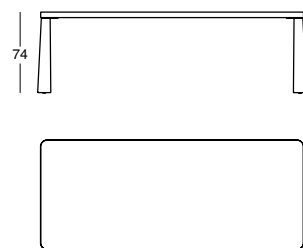

Dimensioni/Sizes/
Dimensions/
Abmessungen/
Medidas

100x190 cm
100x240 cm
100x270 cm
150x150 cm

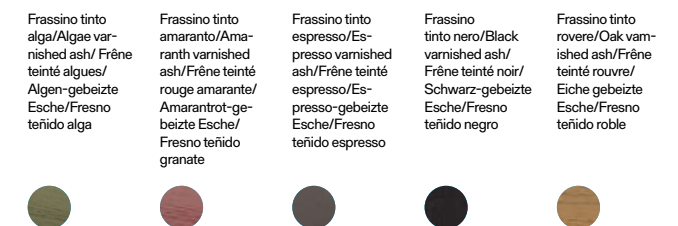

Tucano ²⁷⁴⁰



Design

Monica Förster

2020

Scrivania

Struttura in acciaio verniciato colore nero opaco. Piano rivestito in cuoio pigmentato 90.

Writing desk

Matt black varnished steel frame. Top covered with cowhide pigmentato 90.

Table bureau

Structure en acier verni noir mat. Plateau en cuir sellier pigmentato 90.

Schreibtisch

Gestell aus mattem schwarz lackiertem Stahl. Platte mit Kernleder pigmentato 90 bezogen.

Escritorio

Estructura de acero pintado color negro mate. Superficie tapizada de cuero pigmentado 90.

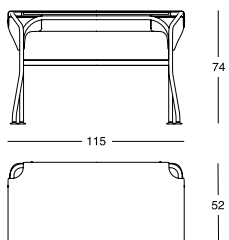

Tweed ²³¹⁶

NEW PRODUCT



Design

Garcia Cumini

2017

Tavolo

Piano in legno placcato in rovere, verniciato colore naturale, con sottopiano verniciato colore grigio, o a poro aperto colore nero, con sottopiano verniciato colore nero, oppure in noce Canaletto, verniciato colore naturale, con sottopiano verniciato colore nero. Gambe in abbinamento rispettivamente in legno massello di rovere verniciato colore naturale, o di rovere verniciato a poro aperto nero, oppure di noce Canaletto, verniciato colore naturale. Piedino regolabile in alluminio verniciato nero.

Table

Top available either in natural painted oak veneered wood, with grey painted under-top, or black painted with an open pore, with black painted under-top or in natural painted Canaletto walnut veneered wood, with black painted under-top. Legs are available respectively in natural painted solid oak, or in open pore black painted oak, or in natural painted Canaletto walnut. Black painted aluminium adjustable foot.

Table

Plateau en bois plaqué dans la finition rouvre, verni couleur naturel, avec un sous-plateau verni gris, ou verni à pore ouvert noir avec sous-plateau verni noir, ou plaqué en noyer Canaletto, verni couleur naturel avec un sous-plateau verni noir. Pieds en combinaison respectivement en bois massif de rouvre, verni couleur naturel, ou en rouvre verni à pore ouvert noir, ou en noyer Canaletto, verni couleur naturel. Petit pied réglable en aluminium verni noir.

Tisch

Holzplatte furniert mit naturfarbenen lackierter Eiche, mit grau lackierter Unterplatte, oder mit naturfarbenen lackiertem Nussbaum Canaletto, mit schwarz lackierter Unterplatte. Beine aus massiver Eiche, naturfarben lackiert, oder bzw. aus schwarz lasierter Eiche oder bzw. aus Nussbaum Canaletto, naturfarben lackiert. Verstellbarer Fuß aus schwarz lackiertem Aluminium.

Mesa

Superficie de madera chapada en roble barnizado natural, con la parte inferior pintada de color gris, o pintado a poro abierto, color negro, con la parte inferior pintada de color negro, o en nogal Canaletto barnizado natural, con la parte inferior pintada de color negro. Patas combinadas respectivamente en madera maciza de roble, barnizado natural, o de roble pintado a poro abierto negro, o de nogal Canaletto barnizado natural. Pie regulable en aluminio pintado negro.

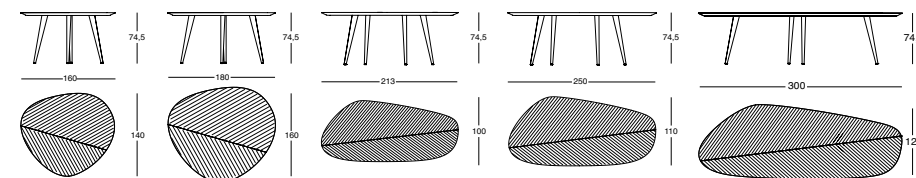

Piano/Top/Plateau/Platte/Sobre

Rovere naturale/ Natural oak-wood/Rouvre naturel/Naturfarbene Eiche/Roble natural
 Rovere tinto nero/ Black varnished oak/Rouvre teinté noir/Schwarzgebeizte Eiche/Roble teñido negro
 Noce Canaletto/ Canaletto walnut/ Noyer Canaletto/ Nussbaum Canaletto/Nogal Canaletto





Design

Garcia Cumini

2017

Tavolo

Piano in MDF laccato opaco colore canapa, amaranto, espresso, antracite e nero. Gambe in legno laccate nei medesimi colori dei piani. Piedini regolabili in alluminio verniciato nero.

Table

MDF top, matt lacquered in the colours hemp, amaranth, espresso, anthracite and black. Legs lacquered in the same colours as the top. Black painted aluminium adjustable feet.

Table

Plateau en MDF, verni mat dans les couleurs chanvre, rouge amarante, espresso, anthracite et noir. Pieds laqués dans les memes couleurs du plateau. Petites pieds réglables en aluminium verni noir.

Tisch

MDF-Platte, matt lackiert in den Farben Hanf, Amaranthrot, Espresso, Anthrazit und schwarz. Beine lackiert in denselben Farben wie die Platte. Verstellbare Füße aus schwarz lackiertem Aluminium.

Mesa

Sobre de MDF, lacado mate en los colores cáñamo, granate, espresso, antracita y negro. Patas lacadas en los mismos colores del sobre. Pies regulables en aluminio pintado negro.

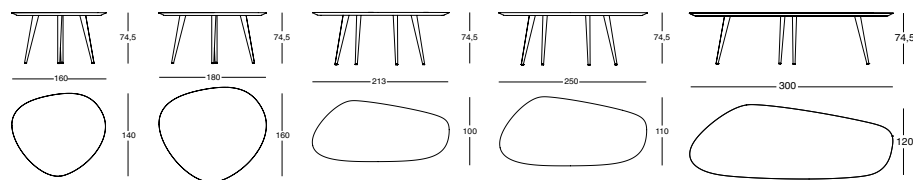

Struttura/Frame/Structure/
Gestell/Estructura



Design

Garcia Cumini

2023

Tavolo

Piano in marmo Striato Olimpico con verniciatura protettiva antimacchia in poliestere trasparente opaca. Sotto piano in MDF laccato colore nero opaco. Gambe in tubolare di acciaio verniciato colore nero opaco.

Table

Top in Striato Olimpico marble with stain resistant protective varnish in clear matt polyester. MDF under-top, lacquered matt black. Legs in matt black painted tubular steel.

Table

Plateau en marbre Striato Olimpico, vernis de protection anti-taches en polyester transparent mat. Sous-plateau en MDF, laqué noir mat. Pieds en tube d'acier verni noir mat.

Tisch

Platte aus Striato Olimpico-Marmor, mit Fleckenschutz Lackierung aus transparentem matten Polyester. Unterplatte aus matt schwarz lackiertem MDF. Beine aus matt schwarz lackiertem Stahlrohr.

Mesa

Sobre de mármol Striato Olimpico, con laca de protección antimancha, en poliéster opaco transparente. Parte inferior de MDF lacado en negro mate. Patas de tubo de acero pintadas en negro mate.

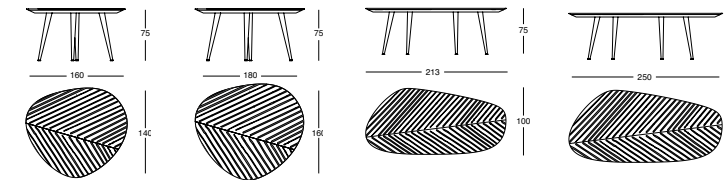

Zavolo Consolle ⁷⁹²

NEW PRODUCT



Design

Zaven

2024

Consolle

Struttura in MDF, laccatura opaca nei colori talco, cera, lilla, canapa, caramello, arancione, amaranto, verde prato, espresso e nero. Prevede il fissaggio a parete.

Console table

MDF frame, matt lacquered in the colours talc, wax, lilac, hemp, caramel, orange, amaranth, grass green, espresso and black. Must be fastened to wall.

Console

Structure en MDF, laquée mat dans les couleurs talc, cire, lilas, chanvre, caramel, orange, rouge amarante, vert pré, espresso et noir. Il prévoit le montage mural.

Wandtisch

Gestell aus MDF, matt lackiert in den Farben Talkum, Wachs, Flieder, Hanf, Karamell, Orange, Amarantröt, grasgrün, Espresso und schwarz. Für die Wandmontage vorgesehen.

Consola

Estructura de MDF, lacado mate en los colores talco, cera, lila, cáñamo, caramelo, naranja, granate, verde prado, espresso y negro. Debe ser fijada a la pared.

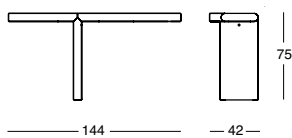

Struttura/Frame/Structure/Gestell/Estructura



Letti
Beds
Lits
Betten
Camas



Design

Emaf Progetti

2005

Letti con o senza vano contenitore

Struttura in acciaio. Molleggio in doghe di faggio curvato con regolatori di rigidità. Testiera e base imbottite in poliuretano/fibra poliestere termolegata. Rivestimento trapuntato, sfilabile, in stoffa o in pelle. Il letto, nella versione 1874, all'interno della base, è dotato di un vano contenitore

al quale si accede alzando il materasso tramite un meccanismo. A richiesta, solo per il modello 1875, è possibile fornire il letto con supporti angolari regolabili che permettono l'inserimento della rete ad altezze diverse e la misura per il materasso da 210 cm di lunghezza.

Beds with or without container unit

Steel frame. Suspension in bent beech strips with stiffness adjusters. Upholstered base and headboard in polyurethane/heat-bound polyester fibre. Removable quilted cover in fabric or leather. The model 1874, fitted inside the base, is furnished with a container unit accessed by lifting the

mattress with a special device. Upon request, only for the model 1875, the bed with adjustable corner supports that enable to place the springing at different heights and the bed size for 210 cm. long mattress can be supplied.

Lits avec ou sans élément de rangement

Structure en acier. Suspension en douves de hêtre courbé, avec régulateurs de rigidité. Cadre et tête de lit rembourrés en polyuréthane/fibre polyester liée à chaud. Revêtement surpiqué déhoussable en tissu ou en cuir. En version 1874 le lit, à l'intérieur du cadre, est doté d'un élément

de rangement auquel l'on accède en levant le matelas à l'aide d'un mécanisme. Sur demande, seulement pour le modèle 1875, il est possible de fournir le lit avec des supports angulaires réglables qui permettent l'introduction du sommier à des hauteurs différentes et dans la mesure pour un matelas de 210 cm de longueur.

Betten mit oder ohne Stauraum
Gestell aus Stahl. Lattenrost aus gebogenen Buchen- Dauben, in der Nachgiebigkeit regulierbar. Unterteil und Kopfteil mit Polsterung aus Polyurethan/wärmegebundener Polyesterfaser. Abnehmbarer Bezug aus Stepp-Stoff oder Leder. Die Ausführung 1874 hat im Bettrahmen einen integrierten Stauraum, der über einen Mechanismus zum Anheben

der Matratze zugänglich wird. Auf Nachfrage, nur für die Version 1875, ist das Bett mit verstellbaren Winkelhalterungen lieferbar, die die Einfügung des Rostes in verschiedenen Höhen ermöglichen. Die Bett-Maße für die Matratze 210 cm lang ist auch verfügbar.

Camas con o sin base contenedora
Estructura de acero. Somier con lamas de haya curvadas con reguladores de rigidez. Base y cabezal acolchados de poliuretano/fibra poliéster termounida. Tapizado pespunteado desenfundable de tejido o de piel. El modelo 1874 está provisto de una base contenedora a la cual se accede alzando el colchón por medio de un mecanismo al efecto. Sobre pedido, solo por el modelo 1875

podemos suministrar la cama con los soportes angulares regulables para poder poner el somier a alturas diferentes y en la medida para el colchón de 210 cm de largo.

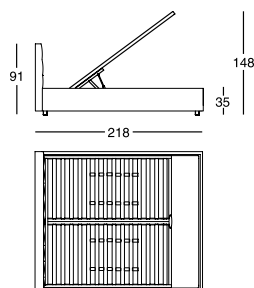

1874

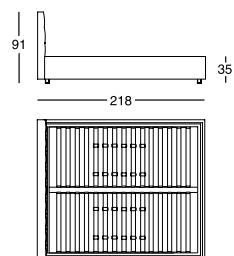

1875

Dimensioni/Sizes/Dimensions/Abmessungen/Medidas

15x218 cm	(140x200 cm)*
17x218 cm	(160x200 cm)*
19x218 cm	(180x200 cm)*
21x218 cm	(200x200 cm)*

* Dimensioni del materasso/Mattress sizes/ Dimensions du matelas/ Abmessungen der Matratze/Medidas del colchón



Design

Gabriele Rosa

2018

Letti con rete unica o separata

Piedini e mensole in acciaio rivestiti in cuoio pigmentato 90 nel medesimo colore. Struttura in acciaio con doghe in faggio curvato, verniciato naturale. Imbottitura testiera e base in poliuretano/fibra poliestere termolegata. Rivestimento, sfilabile, in stoffa o pelle. A richiesta sono disponibili le

misure per i materassi da 210 e 220 cm di lunghezza ed è possibile rivestire interamente il retro della testiera nel medesimo tessuto o pelle del letto.

Beds with single or separate springing

Steel feet and shelves covered with cowhide pigmentato 90 in the same colour. Steel frame with suspension on natural bent beech strips. Base and headboard upholstered in polyurethane/heat bound polyester fibre. Removable fabric or leather cover. Upon request the bed sizes for

210 cm. and 220 cm. long mattresses are available, as well as the headboard can be fully covered with the same fabric or leather of the bed.

Lits avec sommier single ou séparé

Pieds et étagère en acier recouverts en cuir sellier pigmentato 90 dans la même couleur. Structure en acier avec douves en hêtre courbé, verni naturel. Cadre et tête de lit rembourrés en polyuréthane/fibre polyester liée à chaud. Revêtement déhoussable en tissu ou en cuir. Sur demande, il sont

prévus les mesures pour des matelas de 210 cm. et 220 cm de longueur et il est possible de couvrir complètement le dos de la tête de lit avec le même tissu ou cuir que le lit.

Betten mit einzelner oder getrenntem Lattenrost

Stahl-Füße und Stützfläche bezogen mit Kernleder pigmentato 90 in der derselben Farbe. Stahl-Gestell mit gebogenen Buchen-Dauben, naturfarben lackiert. Kopfteil und Unterteil mit Polyurethan/wärmegebundener Polyesterfaser gepolstert. Abnehmbarer Bezug aus Stoff oder Leder. Auf Nachfrage sind die Bett-Maßen für die Matratzen

210 cm und 220 cm lang verfügbar und kann das ganze Kopfteil in dem gleichen Stoff oder Leder des Bettes bezogen werden.

Camas con somier unico o separado

Patas y repisa de acero tapizados de cuero pigmentato 90 del mismo color. Estructura de acero con lamas de haya curvada, barnizado natural. Base y cabezal acolchados de poliuretano/fibra poliéster termounida. Tapizado desenfundable de tejido o de piel. Sobre pedido están disponibles las medidas de la cama para colchones de 210 cm y 220 cm de largo;

es posible también tapizar completamente la parte trasera del cabezal con el mismo tejido o piel de la cama.

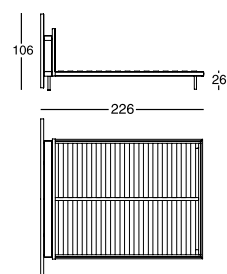

Dimensioni/Sizes/Dimensions/Abmessungen/Medidas

205x226 cm	(140x200 cm)*
221x226 cm	(160x200 cm)*
235x226 cm	(170x200 cm)*
240x226 cm	(180x200 cm)*

* Dimensioni del materasso/Mattress sizes/ Dimensions du matelas/ Abmessungen der Matratze/Medidas del colchón



Design

De Pas, D'Urbino, Lomazzi

1983

Letto

Struttura in acciaio con doghe in faggio curvato. Piedini in acciaio nichelsatinato colore naturale o nero che permettono di ottenere diverse altezze del letto. Rivestimento sfilabile, in tessuto o pelle o non sfilabile

in cuoio. La versione in cuoio ha le cuciture in filo bianco. A richiesta è disponibile anche la misura per il materasso da 210 cm di lunghezza.

Bed

Steel frame with bent beech strips. Steel feet, with natural or black nickel-satin finish that allow different heights of the bed. Removable fabric or leather cover, or non-removable in cowhide. The version in cowhide has

the stitching in white thread. Upon request the bed size for 210 cm. long mattress is also available.

Lit

Structure en acier avec douves en hêtre courbé. Pieds en acier nickel satiné, dans les couleurs naturel ou noir que permettent d'obtenir différentes hauteurs du lit. Revêtement déhoussable, en tissu ou cuir ou non

déhoussable en cuir sellier. La version en cuir sellier a les coutures en fil blanc. Sur demande, il est prévu aussi la mesure pour un matelas de 210 cm de longueur.

Bett

Stahlgestell mit Lattenrost aus gebogenen Buchen-Dauben. Füße aus Stahl mit naturfarben- oder schwarz- vernickeltem und mattiertem Finish, die verschiedene Betthöhen erlauben. Abnehmbarer

Bezug aus Stoff oder Leder oder nicht abziehbares aus Kernleder. Die Nähte der Kernlederausführung sind weiß. Auf Nachfrage ist die Bett- Maße für die Matratze 210 cm lang auch verfügbar.

Cama

Estructura de acero con lamas de haya curvadas. Pies de acero niquelado mate en los acabados natural o negro que permiten diferentes alturas de la cama. Tapizado de tejido o de piel, desenfundable, o de cuero,

fijo. La versión en cuero tiene las costuras en hilo blanco. Sobre pedido está también disponible la medida de la cama para el colchón de 210 cm de largo.

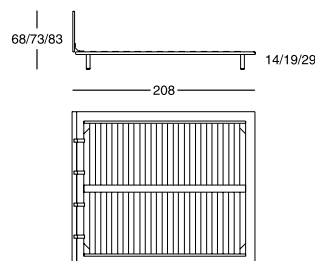

Dimensioni/Sizes/Dimensions/ Abmessungen/Medidas

93x208 cm	(90x200 cm)*
143x208 cm	(140x200 cm)*
163x208 cm	(160x200 cm)*
183x208 cm	(180x200 cm)*
203x208 cm	(200x200 cm)*

* Dimensioni del materasso/Mattress sizes/ Dimensions du matelas/ Abmessungen der Matratze/Medidas del colchón

Piedini/Feet/Pieds/Füße/Patas





Design

Emaf Progetti

2010

Letti

Struttura smontabile in acciaio verniciato, colore talco o nero. Molleggio in doghe di faggio curvato con regolatori di rigidità. La versione 1707 è dotata di cuscini testiera in piuma d'oca - materiale 100%

vergine con inserto in poliuretano. Rivestimento sfilabile in stoffa o pelle (solo per il mod. 1707). A richiesta è disponibile anche la misura per il materasso da 210 cm di lunghezza.

Beds

Demountable steel frame painted in the shade of talc or black. Springing in bent beech strips, with stiffness adjusters. Version 1707 has headboard cushions with goose down - 100% pure material, with polyurethane

insert. Removable fabric or leather cover (only for model 1707). Upon request the bed size for 210 cm. long mattress is also available.

Lits

Structure démontable en acier laqué, talc ou noire. Suspension en douves de hêtre courbé, avec régulateurs de rigidité. Dans la version 1707, les coussins à la tête du lit sont en plumes d'oie - matériau

100 % vierge, avec insert en polyuréthane. Revêtement déhoussable en tissu ou en cuir (seulement pour le modèle 1707). Sur demande, il est prévu aussi la mesure pour un matelas de 210 cm de longueur.

Betten

Zerlegbares Gestell aus Talkum- oder schwarz lackiertem Stahl. Lattenrost aus gebogenen Buchen-Dauben, in der Nachgiebigkeit regulierbar. Bei der Ausführung 1707 sind die Kissen des Kopfteils mit

100% reinen Gänsedaunen gefüllt, mit Einlage aus Polyurethan. Abnehmbarer Bezug aus Stoff oder Leder (nur fürs Modell 1707). Auf Nachfrage ist die Bett-Maße für die Matratze 210 cm lang auch verfügbar.

Camas

Estructura desmontable de acero barnizado, color talco o negro. Somier con lamas de haya curvadas, con reguladores de rigidez. La versión 1707 está dotada de cojines de cabezal en plumón de ganso - material

100% virgen con inserción de poliuretano. Tapizado desenfundable en tejido o piel (solo por el modelo 1707). Sobre pedido está también disponible la medida de la cama para el colchón de 210 cm de largo.

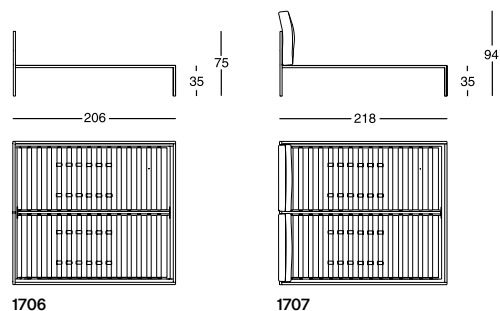

Dimensioni/Sizes/Dimensions/Abmessungen/Medidas

Mod. 1706		Mod. 1707	
96x206 cm	(90x200 cm)*	96x218 cm	(90x200 cm)*
146x206 cm	(140x200 cm)*	146x218 cm	(140x200 cm)*
166x206 cm	(160x200 cm)*	166x218 cm	(160x200 cm)*
186x206 cm	(180x200 cm)*	186x218 cm	(180x200 cm)*
206x206 cm	(200x200 cm)*	206x218 cm	(200x200 cm)*

Piedini/Feet/Pieds/FüÙe/Patas



* Dimensioni del materasso/Mattress sizes/Dimensions du matelas/Abmessungen der Matratze/Medidas del colchón

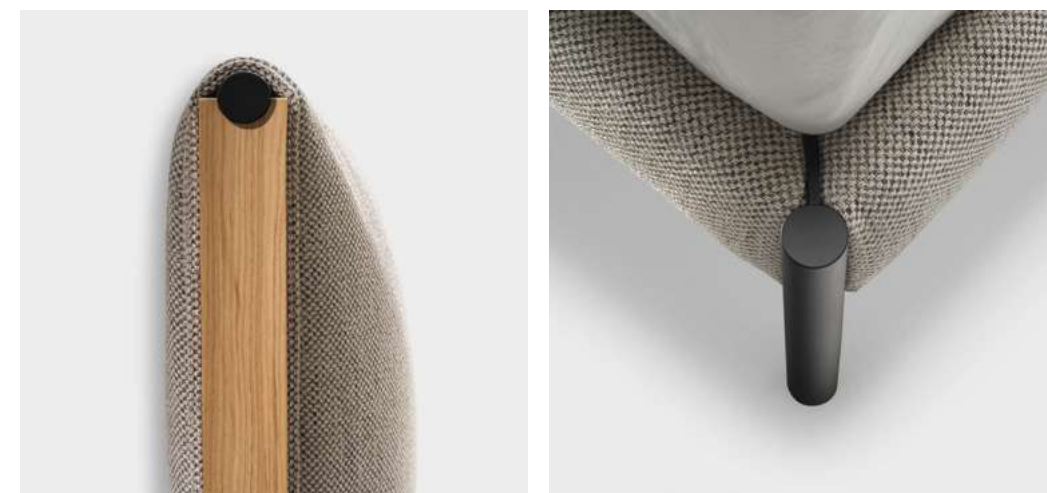

Design

Spalvieri & Del Ciotto

2020

Letti con rete unica o separata

Struttura testiera in rovere naturale o verniciato a poro aperto colore nero. Imbottitura in poliuretano/ fibra poliestere termolegata. Piedi anteriori e asta superiore testiera in acciaio verniciato colore nero opaco. Rivestimento sfilabile in

stoffa o pelle. Struttura base in acciaio con doghe in faggio curvato verniciato naturale. A richiesta è disponibile anche la misura per il materasso da 210 cm di lunghezza.

Beds with single or separate springing
Headboard frame in natural or in black open pore painted oak. Upholstery in polyurethane/heat-bound polyester fibre. Front feet and headboard upper rod in matt black varnished steel. Removable fabric or leather cover. Steel base with natural

bent beech strips. Upon request the bed size for 210 cm long mattress.

Lits avec sommier single ou séparé
Structure tête et pied du lit en rovere naturel ou verni à pore ouvert, dans la couleur noire. Rembourrage en polyuréthane/fibre polyester liée à chaud. Pieds avant et tête de lit supérieure en acier peint en noir mat. Revêtement déhoussable

en tissu ou en cuir. Structure en acier avec douves en hêtre courbé verni naturel. Sur demande il est possible de commander le lit pour le matelas en longueur de 210 cm.

Betten mit einzelner oder getrenntem Lattenrost
Kopfteil aus naturfarbener oder schwarz lasierter Eiche. Polsterung aus Polyurethan/wärmegebundener Polyesterfaser. Vordere Füße und obere Stange des Kopfteils aus mattem schwarz lackiertem Stahl. Abnehmbarer Bezug aus

Stoff oder Leder. Unterteil-Gestell aus Stahl mit Lattenrost aus gebogenen Buchen-Dauben, naturfarben lackiert. Auf Nachfrage sind die Bett-Maße für die Matratze 210 cm lang verfügbar.

Cama con somier unico o separado
Estructura cabezal y pies en roble natural o lacado a poro abierto color negro. Acolchado de poliuretano/ fibra de poliéster termounida. Patas anteriores y varilla superior del cabezal en acero pintado color negro mate. Tapizado desenfundable de

tejido o piel. Estructura de acero con lamas de haya curvada, barnizado natural. Sobre pedido la cama puede realizarse para alojar un colchón de 210 cm de largo.

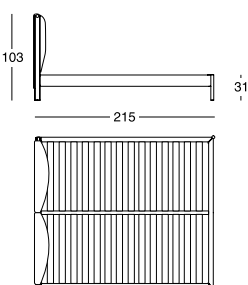

Dimensioni/Sizes/Dimensions/Abmessungen/Medidas

173x215 cm	(160x200)*
183x215 cm	(170x200)*
193x215 cm	(180x200)*

* Dimensioni del materasso/Mattress sizes/ Dimensions du matelas/ Abmessungen der Matratze/Medidas del colchón

Struttura/Frame/Structure/Gestell/Estructura

Rovere naturale/Natural oakwood/ Rouvre naturel/Naturfarbene Eiche/ Roble natural



Rovere tinto nero/Black varnished oak/ Rouvre teinté noir/Schwarz-gebeizte Eiche/Roble teñido negro



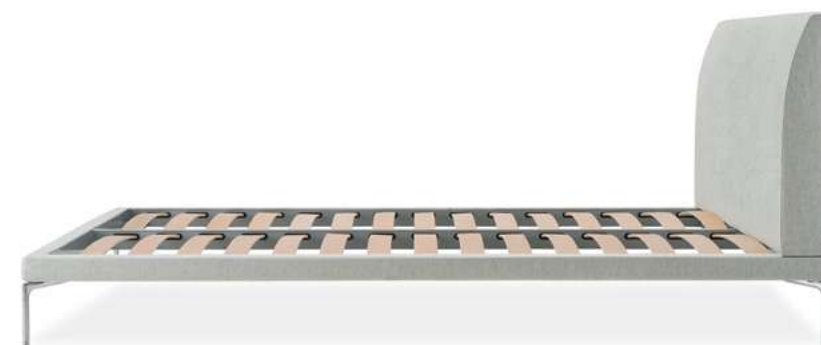

Design

Damian Williamson

2011

Letti con rete unica o separata

Piedini in lega di alluminio lucidato o nichelsatinato colore naturale o nero, oppure verniciato nero. Struttura in acciaio con doghe in faggio curvato. Imbottitura testiera in poliuretano/fibra poliestere termolegata. Rivestimento

sfilabile in stoffa o pelle. A richiesta sono disponibili anche le misure per i materassi da 210 e 220 cm di lunghezza.

Beds with single or separate springing

Polished or black painted aluminium alloy feet, or with natural or black nickel-satin finish. Steel frame with suspension in bent beech strips. Headboard upholstered with polyurethane/heat-bound polyester fibre. Removable

fabric or leather cover. Upon request the bed sizes for 210 cm. and 220 cm. long mattresses are also available.

Lits avec sommier single ou séparé

Pieds en alliage d'aluminium poli ou nickel satiné, dans les couleurs naturel ou noir, ou verni noir. Structure en acier avec douves en hêtre courbé. Rembourrage de la tête de lit en polyuréthane/fibre polyester liée à chaud. Revêtement déhoussable

en tissu ou en cuir. Sur demande, ils sont prévus aussi les mesures pour des matelas de 210 cm. ou 220 cm. de longueur.

Betten mit einzelner oder getrenntem Lattenrost

Füße aus polierter oder schwarz-lackierter Aluminiumlegierung oder mit naturfarben- oder schwarz-vernicheltem und mattiertem Finish. Stahlgestell mit gebogenen Buchen-Dauben. Kopfteilpolsterung aus Polyurethan/ wärme-

gebundener Polyesterfaser. Abnehmbarer Bezug aus Stoff oder Leder. Auf Nachfrage sind die Bett-Maßen für die Matratzen 210 cm und 220 cm lang auch verfügbar.

Cama con somier unico o separado

Pies de aleación de aluminio pulido o niquelado mate en los acabados natural o negro, o pintado negro. Estructura de acero con lamas de haya curvada. Cabezal acolchado de poliuretano/fibra poliéster termounida. Tapizado desenfundable, de

tejido o de piel. Sobre pedido están también disponibles las medidas de la cama para colchones de 210 cm y 220 cm de largo.

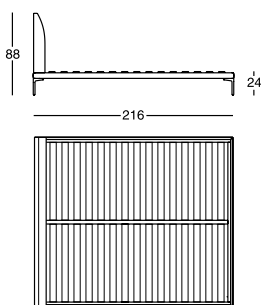

1883

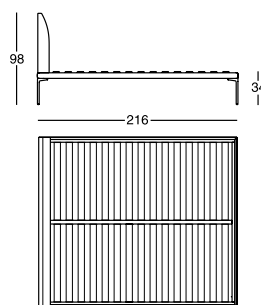

1884

Dimensioni/Sizes/Dimensions/Abmessungen/Medidas

166x216 cm	(160x200 cm)*	1883	1884
176x216 cm	(170x200 cm)*	piedino h. 17,5 cm	piedino h. 27,5 cm
186x216 cm	(180x200 cm)*	foot h. 17,5 cm	foot h. 27,5 cm
206x216 cm	(200x200 cm)*	pied h. 17,5 cm	pied h. 27,5 cm
		Fuß h. 17,5 cm	Fuß h. 27,5 cm
		pie h. 17,5 cm	pie h. 27,5 cm

* Dimensioni del materasso/Mattress sizes/ Dimensions du matelas/ Abmessungen der Matratze/Medidas del colchón

Piedini/Feet/Pieds/Füße/Patas





Design

Damian Williamson

2011

Letto con vano contenitore
Struttura rete in acciaio verniciato colore alluminio. Molleggio in doghe di faggio curvato, colore naturale. Imbottitura testiera in poliuretano schiumato autoestinguente/fibra poliestere termolegata. Rivestimento sfilabile in stoffa o pelle. Il letto,

all'interno della base, è dotato di un vano contenitore, al quale si accede alzando la rete tramite un meccanismo.

Bed with container unit
Aluminium varnished steel springing frame. Suspension in natural bent beech strips. Upholstered headboard in self-extinguishing polyurethane foam/heat-bound polyester fibre. Removable cover in fabric or leather. The bed fitted inside the base, is furnished with a

container unit accessed by lifting the springing with a special device.

Lit avec élément de rangement
Sommier en acier verni, couleur aluminium. Suspensions en douves de hêtre courbé, couleur naturelle. Tête de lit rembourré en mousse de polyuréthane autoextinguible/fibre polyester liée à chaud.

Revêtement déhoussable en tissu ou en cuir. Le lit, à l'intérieur du cadre, est doté d'un élément de rangement auquel l'on accède en levant le sommier à l'aide d'un mécanisme.

Bett mit Stauraum
Bettkasten aus alufarben lackiertem Stahl. Lattenrost aus gebogenen Buchen-Dauben, naturfarben. Kopfteil mit selbstlöschendem Polyurethanschaum/wärmegebundener Polyesterfaser gepolstert. Abnehmbarer Bezug aus Stoff oder Leder. Das Bett

hat im Bettrahmen einen integrierten Stauraum, der über einen Mechanismus zum Anheben der Bettkasten zugänglich wird.

Cama con base contenedora
Estructura somier de acero pintado color aluminio. Suspension con lamas de haya curvadas, de color natural. Cabezal acolchado de espuma de poliuretano autoextintivo/ fibra poliéster termounida. Tapizado desenfundable de tejido o de

piel. La cama está provista de una base contenedora a la cual se accede alzando el somier por medio de un mecanismo.

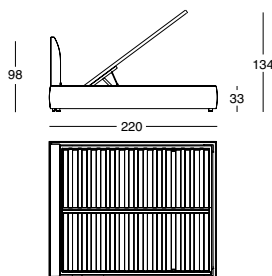

Dimensioni/Sizes/Dimensions/ Abmessungen/Medidas

172x220 cm (160x200 cm)*
182x220 cm (170x200 cm)*
192x220 cm (180x200 cm)*

* Dimensioni del materasso/Mattress sizes/ Dimensions du matelas/ Abmessungen der Matratze/Medidas del colchón

Za:Za Bed ¹⁷⁵⁰

NEW PRODUCT



Za:Za Bed ¹⁷⁵¹

NEW PRODUCT



Design

Zaven

2024

Letto con vano contenitore.

Testiera e base in MDF, imbottitura testiera e base in sfere di poliestere rigenerato e rigenerabile. Struttura rete in acciaio verniciato colore alluminio. Molleggio in doghe di faggio curvato, colore naturale. Rivestimento interno in tessuto di poliestere rigenerato e rigenerabile; rivestimento sfilabile, in stoffa. Il letto, all'interno della base, è dotato di un vano contenitore, al quale si accede alzando la rete tramite un meccanismo.

Bed with container unit.

Base and headboard in MDF upholstered with regenerated and regenerable polyester balls. Aluminium varnished steel springing frame. Suspension in natural bent beech strips. Internal regenerated and regenerable polyester fabric; removable fabric cover. The bed fitted inside the base, is furnished with a container unit accessed by lifting the springing with a special device.

Lit avec élément de rangement

Base et tête de lit en MDF rembourrés en boules de polyester régénéré et régénérable. Sommier en acier verni, couleur aluminium. Suspensions en douves de hêtre courbé, couleur naturelle. Revêtement intérieur en tissu de polyester régénéré et régénérable. Revêtement déhoussable en tissu. Le lit, à l'intérieur du cadre, est doté d'un élément de rangement auquel l'on accède en levant le sommier à l'aide d'un mécanisme.

Bett mit Stauraum

Kopfteil und Unterteil aus MDF mit Polsterung aus regenerierten und regenerierbaren Polyesterkugeln. Bettkasten aus alufarben lackiertem Stahl. Lattenrost aus gebogenen Buchen-Dauben, naturfarben. Innenbezug aus regeneriertem und regenerierbarem Polyesterstoff; abnehmbarer Bezug aus Stoff. Das Bett hat im Bettrahmen einen integrierten Stauraum, der über einen Mechanismus zugänglich wird.

Cama con base contenedora

Cabezal y base de MDF, acolchados con bolas de poliéster regenerado y regenerable. Estructura somier de acero pintado color aluminio. Suspension con lamas de haya curvadas, de color natural. Tapizado interior en tejido de poliéster regenerado y regenerable; tapizado exterior desenfundable de tejido. La cama está provista de una base contenedora a la cual se accede alzando el somier por medio de un mecanismo.

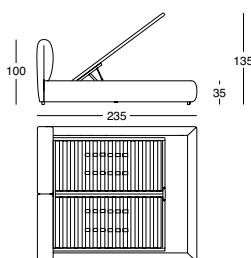

Dimensioni/Sizes/Dimensions/ Abmessungen/Medidas

195x235 cm (160x200 cm)*
205x235 cm (170x200 cm)*
215x235 cm (180x200 cm)*

* Dimensioni del materasso/Mattress sizes/ Dimensions du matelas/ Abmessungen der Matratze/Medidas del colchón

Design

Zaven

2024

Letto

Testiera e base in MDF, imbottitura testiera e base in sfere di poliestere rigenerato e rigenerabile. Rivestimento interno in tessuto di poliestere rigenerato e rigenerabile, rivestimento sfilabile in stoffa. Il letto è dotato di angolari regolabili in altezza su cui appoggiano le reti di supporto al materasso fornite a parte.

Bed

Base and headboard in MDF upholstered with regenerated and regenerable polyester balls. Internal regenerated and regenerable polyester fabric; removable fabric cover. The bed is equipped with height-adjustable corner supports on which the separately supplied springing can be placed.

Lit

Base et tête de lit en MDF rembourrés en boules de polyester régénéré et régénérable. Revêtement intérieur en tissu de polyester régénéré et régénérable. Revêtement déhoussable en tissu. Le lit est fourni avec des supports angulaires réglables en hauteur qui permettent l'introduction du sommier sur lesquels reposent les sommiers fournis séparément.

Bett

Kopfteil und Unterteil aus MDF mit Polsterung aus regenerierten und regenerierbaren Polyesterkugeln. Innenbezug aus regeneriertem und regenerierbarem Polyesterstoff; abnehmbarer Stoff-Bezug. Das Bett ist mit höhenverstellbaren Winkelhalterungen ausgestattet, auf die die separat mitgelieferten Bettroste aufgesetzt werden können.

Cama

Cabezal y base de MDF, acolchados con bolas de poliéster regenerado y regenerable. Tapizado interior en tejido de poliéster regenerado y regenerable; tapizado desenfundable de tejido. La cama está provista con los soportes angulares regulables en altura en las que se pueden colocar el somier suministrado por separado.

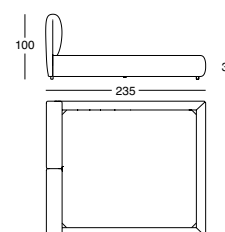

Dimensioni/Sizes/Dimensions/ Abmessungen/Medidas

195x235 cm (160x200 cm)*
205x235 cm (170x200 cm)*
215x235 cm (180x200 cm)*

* Dimensioni del materasso/Mattress sizes/ Dimensions du matelas/ Abmessungen der Matratze/Medidas del colchón

Confortevole ^{1890/1891}

Materasso a molle insacchettate con automodellante/Pocket sprung mattress with memory foam/Matelas à ressorts ensachés avec auto-moulant/Selbstmodellierende Matratze mit Taschenfedern/Colchón de muelles ensacados con auto-amoldante

Dimensioni/Sizes/Dimensions/
Abmessungen/Medidas

80x200 cm
85x200 cm
90x200 cm
100x200 cm
140x200 cm
160x200 cm
170x200 cm
180x200 cm
200x200 cm

1890 - h 20 cm
1891 - h 30 cm

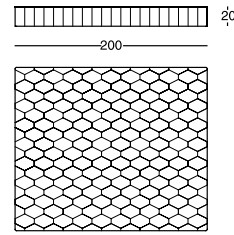

Formaplus ¹⁸⁸⁹

Materasso automodellante/Memory foam mattress/Matelas auto-moulant/Selbstmodellierende Matratze/Colchón auto-amoldante

Dimensioni/Sizes/Dimensions/
Abmessungen/Medidas

80x200 cm
85x200 cm
90x200 cm
100x200 cm
140x200 cm
160x200 cm
170x200 cm
180x200 cm
200x200 cm

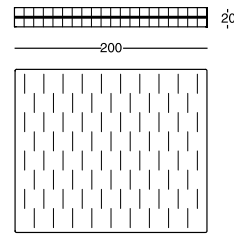

Mollaplus ¹⁸⁸⁷

Materasso a molle insacchettate/Pocket sprung mattress/Matelas à ressorts ensachés/Matratze mit Taschenfedern/Colchón de muelles ensacados

Dimensioni/Sizes/Dimensions/
Abmessungen/Medidas

80x200 cm
85x200 cm
90x200 cm
100x200 cm
140x200 cm
160x200 cm
170x200 cm
180x200 cm
200x200 cm

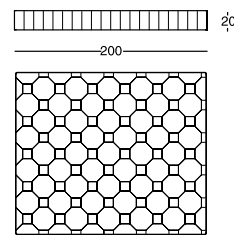

Molleggio ¹⁸⁸⁶

Materasso a molle/Spring mattress/Matelas à ressorts/Matratze mit Stahlfedern/Colchón de muelles

Dimensioni/Sizes/Dimensions/
Abmessungen/Medidas

90x200 cm
140x200 cm
160x200 cm
170x200 cm
180x200 cm
200x200 cm

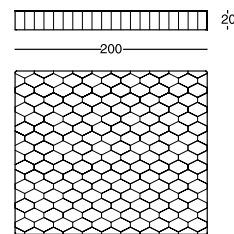

Natura ¹⁸⁹³

Materasso in lattice/Latex mattress/Matelas en latex/Latex-Matratze/Colchón de látex

Dimensioni/Sizes/Dimensions/
Abmessungen/Medidas

80x200 cm
85x200 cm
90x200 cm
100x200 cm
140x200 cm
160x200 cm
170x200 cm
180x200 cm
200x200 cm

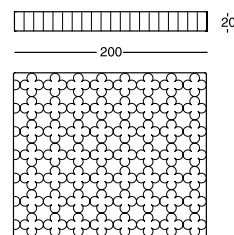

Topper ¹⁸⁹⁸

Materassino aggiuntivo per materassi/Mattress topper/Petit matelas d'appoint pour matelas/Matratzenauflage für normale Matratzen/Colchoncillo adicional para colchones

Dimensioni/Sizes/Dimensions/
Abmessungen/Medidas

80x200 cm
85x200 cm
90x200 cm
100x200 cm
140x200 cm
160x200 cm
170x200 cm
180x200 cm
200x200 cm

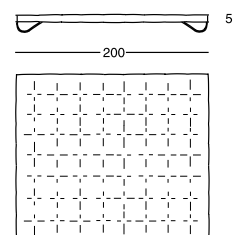

Pisolo ¹⁸⁹⁶

Guanciale in Hollofil/ Hollofil pillow/ Oreiller en Hollofil/ Hollofil Kissen/ Almohada de Hollofil

Guanciale in piuma/ Feather pillow/ Oreiller en plume/ Daunenkissen/ Almohada de pluma

Guanciale automodellante cervicale/Wave-shaped memory foam pillow/Oreiller auto-moulante à deux ondes/Selbstmodellierendes Kissen mit zwei Erhebungen/ Almohada auto-amoldante con doble ola

Guanciale in lattice cervicale/Wave-shaped latex pillow/ Oreiller en latex à deux ondes/Kissen aus Latex mit zwei Erhebungen/Almohada de látex con doble ola

Guanciale in lana/Wool pillow/Oreiller en laine/ Kissen aus Wolle/Almohada de lana

Guanciale automodellante saponetta/Soap-shaped memory foam pillow/Oreiller auto-moulante en forme de savon/Selbstmodellierendes Kissen seifenförmig/ Almohada auto-amoldante de forma tradicional



Reti letto ^{1752/1753/1754}

Reti amovibili

Codice 1752 versione fissa, telaio portante in multistrato di faggio, molleggio in doghe di faggio curvato, colore naturale inserite in giunti basculanti di lattice.

Codice 1753 versione fissa, telaio portante in multistrato di faggio, molleggio in doghe di faggio curvato con carta protettiva anti-umidità, inserite in giunti realizzati in tecnopolimero, zona lombare modulabile con cursori di rigidità. Codice 1754 versione regolabile, doppio telaio portante in multistrato di faggio, molleggio in doghe di faggio curvato con carta protettiva anti-umidità, inserite in giunti realizzati in tecnopolimero, zona lombare modulabile con cursori di rigidità. L'inclinazione dei gruppi di doghe in corrispondenza delle testiere e delle pediere sono regolabili, indipendentemente, mediante movimento a comando manuale.

Bed slatted bases

Removable slatted bases. Code 1752: fixed version, supporting frame in beech plywood, natural colour, suspension in natural colour curved beech slats, inserted in latex tilting joints. Code 1753: fixed version, supporting frame in beech plywood, suspension in curved beech slats with moisture-proof protective paper, inserted in technopolymer joints, adjustable lumbar zone with rigidity sliders. Code 1754 adjustable version: double supporting frame in beech plywood, suspension in curved beech slats with moisture-proof protective paper, inserted in technopolymer joints, adjustable lumbar zone with rigidity sliders. The inclination of the slats in correspondence of the headboard and footboard are adjustable, independently, by means of a manually controlled movement.

Sommiers du lit

Sommiers amovibles. Code 1752: version fixe, cadre de support en contreplaqué de hêtre, suspension en lattes de hêtre courbé, couleur naturelle, insérées dans des joints basculantes en latex. Code 1753: version fixe, cadre de support en contreplaqué de hêtre, suspension en lattes de hêtre courbé, avec papier de protection anti-humidité, insérées dans des joints en technopolymère, zone lombaire réglable avec des curseurs de rigidité. Code 1754 version réglable: double cadre de support en contreplaqué de hêtre, suspension en lattes de hêtre courbé avec papier de protection anti-humidité, insérées dans des joints en technopolymère, zone lombaire réglable avec des curseurs de rigidité. L'inclinaison des lattes au niveau de la tête et du pied de lit peut être réglée indépendamment au moyen d'un mouvement à commande manuelle.

Bett Lattenroste

Abnehmbare Lattenroste. Code-Nr. 1752: feste Version, Tragrahmen aus Buchenspertholz, Federung aus gebogenen Buchenholzlatzen, naturfarben, in Latex-Gelenke eingefügt. Code-Nr. 1753: feste Version, Tragrahmen aus Buchenspertholz, Federung aus gebogenen Buchenholzlatzen mit feuchtigkeitbeständigem Schutzpapier, in Technopolymer-Gelenke eingefügt. Lendenwirbelbereich modulierbar mit Steifigkeitsschiebern. Code-Nr. 1754: verstellbare Version, doppelter Tragrahmen aus Buchenspertholz, Federung aus gebogenen Buchenholzlatzen mit Feuchtigkeitsschutzpapier, in Technopolymer-Gelenke eingefügt. Lendenwirbelbereich modulierbar mit Steifigkeitsschiebern. Die Neigung der Lattengruppen beim Kopf- und Fußteil kann unabhängig voneinander durch eine manuelle gesteuerte Bewegung eingestellt werden.

Somieres para cama

Somieres desmontables. Código 1752 versión fija, marco portante de madera contrachapada de haya, somier con lamas de haya curvadas, color natural, insertadas en juntas basculantes de látex. Código 1753 versión fija, marco portante de madera contrachapada de haya, somier con lamas de haya curvadas con papel protector de la humedad, insertadas en juntas de tecnopolímero, zona lumbar regulable con deslizadores de rigidez. Código 1754 versión regulable, doble marco portante de madera contrachapada de haya, somier con lamas de haya curvadas con papel protector de la humedad, insertadas en juntas de tecnopolímero, zona lumbar regulable con deslizadores de rigidez. La inclinación de los grupos de lamas en los cabezal y pieceros puede ajustarse independientemente mediante un movimiento controlado manualmente.

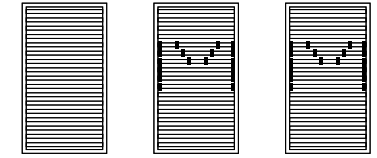

NEW

Lenzuola ¹⁷⁹⁹

Lenzuola

La parure estiva include un lenzuolo sotto, un lenzuolo sopra e due federe per guanciali. La parure invernale include un lenzuolo sotto, un copripiumino e due federe per guanciali. Le parure sono realizzate in Percalle di cotone con cuciture tono su tono nei colori della cartella.

Sheets

The summer set includes a fitted sheet, a top sheet and two pillowcases. The winter set includes a fitted sheet, a duvet cover and two pillowcases. The sets are made of percale cotton with tone-on-tone stitching in the colours of the sample card.

Drap

La parure d'été comprend un drap-housse, un drap de dessus et deux taies d'oreiller. La parure d'hiver comprend un drap-housse, une housse de couette et deux taies d'oreiller. Les parures sont en percale de coton avec des coutures ton sur ton dans les couleurs de la fiche.

Laken

Das Sommer-Set besteht aus einem Spannbettlaken, einem Oberlaken und zwei Kissenbezüge. Das Winter-Set besteht aus einem Spannbettlaken, einem Bettbezug und zwei Kissenbezüge. Die Sets sind aus Baumwolle Perkal mit Ton-in-Ton-Nähten, in den Farben der Musterkarte.

Sábanas

El juego de verano incluye una sábana bajera, una sábana encimera y las dos fundas de almohada. El juego de invierno incluye una sábana bajera, una funda nórdica y las dos fundas de almohada. Los juegos son de percal de algodón con pespunte tono sobre tono en los colores del muestrario.

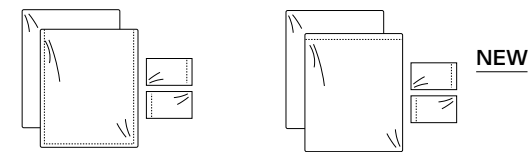

NEW

Complementi
d'arredo
Furnishing
accessories
Compléments
d'ameublement
Wohnaccessoires
Complementos
de decoracion



Design

Achille Castiglioni

1983

Portavasi con piani rotanti
Struttura in acciaio verniciato nei colori talco, amaranto, verde prato o nero. Piattelli portavasi in poliammide, colore nero. Piedini in polipropilene colore nero.

Rotating flowerpot stand
Painted steel frame in the shades talc, amaranth, grass green or black. Pot-holder dishes in black polyamide. Black polypropylene feet.

Jardinière à plateau tournant
Structure en acier verni dans les couleurs talc, rouge amarante, vert pré ou noir. Petits plats en polyamide, couleur noire. Pieds en polypropylène noir.

Blumenständer mit drehbaren Ablagen
Gestell aus lackiertem Stahl, in den Farben Talkum, amarantrot, grasgrün oder schwarz. Polyamid-Untersetzer, schwarzfarben. Füße aus schwarzem Polypropylen.

Macetas con patas giratorias
Estructura en acero pintado en los colores talco, granate, verde prado o negro. Platillos porta-macetas en poliamida color negro. Patas en polipropileno negro.

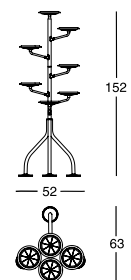

Struttura/Frame/Structure/ Gestell/Estructura



Design

Achille e Pier Giacomo Castiglioni

1965

IN/OUT

Sedile per esterni
Gambe in acciaio, sedile in lega di alluminio, verniciati colore verde prato. Piedini in polietilene, colore naturale.

Outdoor stool
Steel legs, aluminium alloy seat painted grass green. Natural polyethylene feet.

Siège pour extérieurs
Pieds en acier, siège en alliage d'aluminium, vernis vert pré. Pieds en polyéthylène, couleur naturelle.

Stuhl fürs Freie
Beine aus Stahl, Sitz aus Aluminiumlegierung, grasgrün lackiert. Fußenden aus naturfarbenem Polyäthylen.

Taburete para exteriores
Patas de acero, asiento de aleación de aluminio, pintados de color verde prado. Pies de polietileno de color natural.

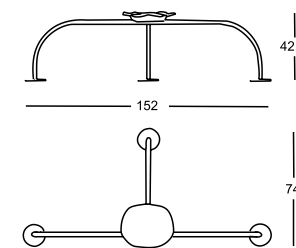

Ara Fenice ⁹⁵⁶⁰

NEW PRODUCT



Design

Piero Bottoni

1951

Alzata

Alzata realizzata in cemento e inerti, colore grigio.

Centerpiece

Centerpiece made of cement and aggregates, colour grey.

Centre table

Centre table en ciment et granulats, de couleur grise.

Tafelaufsatz

Tafelaufsatz aus Zement und Zuschlagstoffen, graufarben.

Centro de mesa

Centro de mesa en cemento y agregados, color gris.

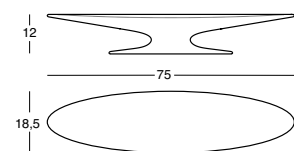

Aster ³⁰³

NEW FINISHES

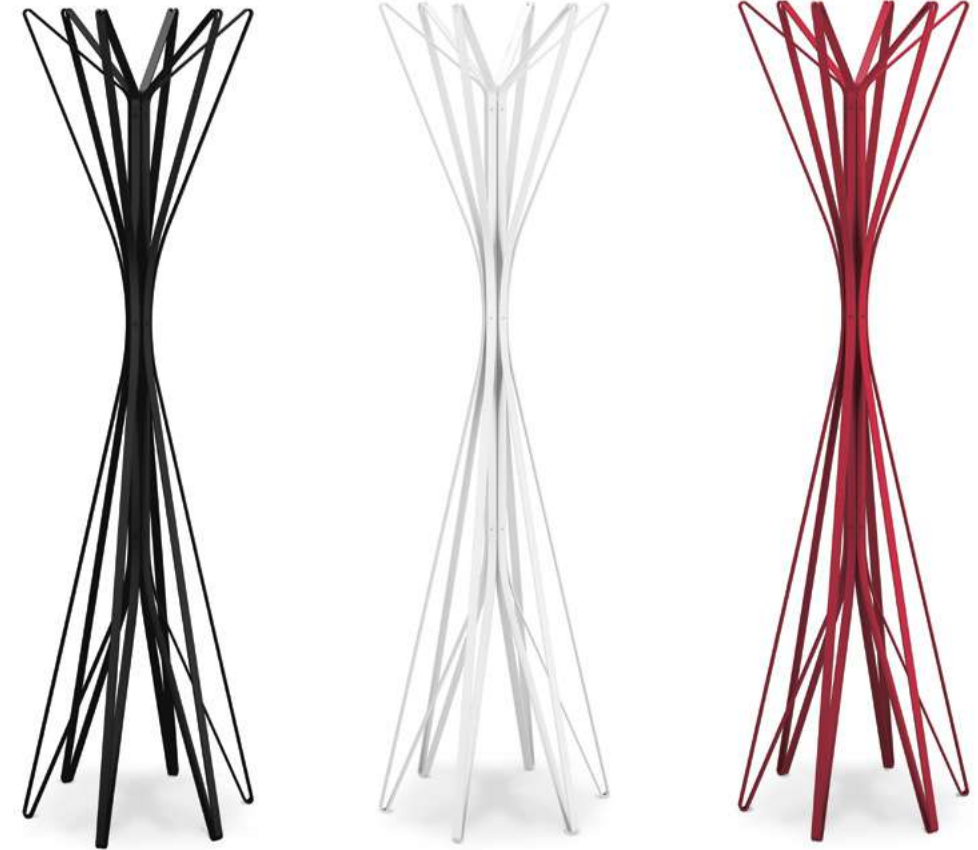

Design

Alessandro Dubini

2010

Appendiabiti

Struttura in acciaio verniciato, colore talco, amaranto o nero.

Clothes stand

Steel frame painted talc, amaranth or black.

Portemanteaux

Structure en acier vernie talc, rouge amarante ou noire.

Kleiderständer

Gestell aus Talkum, amarantrot oder schwarz lackiertem Stahl.

Colgador

Estructura de acero barnizado de color talco, granate o negro.

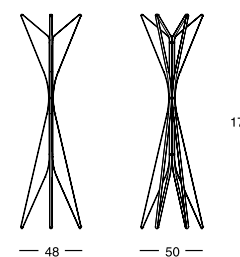

Struttura/Frame/Structure/ Gestell/Estructura





Design

G. Levi Montalcini, G. Pagano Pogatschnig

1932

Portaoggetti

Struttura in tubo di acciaio cromato. Pianetti in laminato plastico stratificato, colore bianco/nero, reversibile.

Objects stand

Chromium-plated, tubular steel frame. Shelves in reversible black/white plastic laminate.

Porte-objets

Structure en tube d'acier chromé. Plateaux en laminé plastique stratifié, couleur blanche/noire, réversible.

Ständer für Gegenstände

Gestell aus verchromtem Stahlrohr. Platten aus Schichtpress-Stoff Laminat, weiß/schwarz, umkehrbar.

Porta objetos

Estructura tubular de acero cromado. Estantes de laminado plástico estratificado, color blanco/negro, reversible.

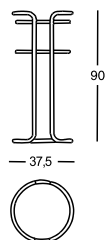

Design

Alessandro Mendini

1985

Ciotola

Ciotola in poliuretano rigido, laccatura lucida brillante bicolore: interno rosso corallo/esterno verde oppure interno amaranto/esterno caramello.

Bowl

Bowl in hard polyurethane, two-tone bright glossy lacquered: coral-red inside/green outside or amaranth inside/caramel outside.

Bol

Structure en polyuréthane rigide, laqué poli brillant bicolore: intérieur rouge corail/extérieur vert ou intérieur rouge amarante/extérieur caramel.

Schale

Form aus hartem Polyurethan, zweifarbig glänzend lackiert: innen Korallenrot/außen grün oder innen Amaranthrot/außen Karamell.

Tazón

Estructura de poliuretano rigido, lacado brillante bicolore: interior rojo coral/exterior verde o interior granate/ exterior caramelo.

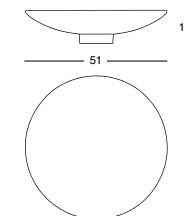



Design

Alessandro Mendini

1986

Vasi

Vasi in argilla smaltata bianca o arancione lucido. Interventi di decorazione ornamentale applicati a mano.

Vases

Vases in white or orange glazed clay. Hand-applied ornamental decoration.

Vases

Vases en terre cuite émaillée blanche ou orange brillante. Décoration ornementale appliquée à la main.

Vasen

Vasen aus weiß oder Orange glasiertem Ton. Handgearbeitete Zierdekoration.

Jarrónes

Jarrónes en arcilla esmaltada blanco o naranja brillante. Intervenciones de decoración ornamental aplicadas a mano.

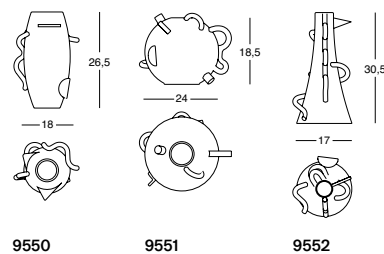

9550

9551

9552



Design

Giuseppe Terragni

1934

Poltroncina

Sedile e schienale colore nero. Balestre di sostegno schienale in acciaio inox 18/8.

Chair

Black seat and back. 18/8 stainless steel backrest support spring.

Petit fauteuil

Siège et dossier couleur noire. Ressort de soutien en acier inox 18/8.

Stuhl

Sitzfläche und Rückenlehne schwarz. Federbogen der Rückenlehne aus Inox- Stahl 18/8.

Butaquita

Asiento y respaldo de color negro. Elementos de soporte respaldo de acero inox 18/8.

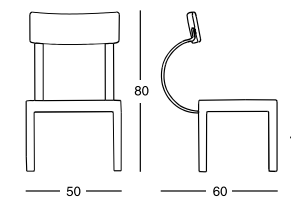



Design

De Pas, D'Urbino, Lomazzi

1975

Sgabello

Struttura in faggio, colore naturale, con crociera rossa. Sedile girevole e regolabile in altezza.

Stool

Natural varnished beech frame with red bracket. Vertically adjustable revolving seat.

Tabouret

Structure en hêtre naturel avec croisillon rouge. Assise tournante et réglable en hauteur.

Hocker

Struktur aus Buche, naturfarben, mit rotem Kreuz. Drehbarer Sitz, höhenverstellbar.

Taburete

Estructura de haya natural con cruceta en rojo. Asiento giratorio y regulable en altura.

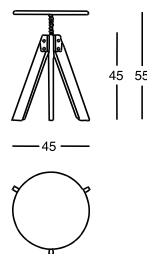

Design

Achille Castiglioni

1989

Libreria a ripiani rotanti

Piani in medium density fiberboard, verniciatura gofrata antigraffio nei colori talco, canapa, amaranto, espresso o nero. Snodo in acciaio verniciato nero nelle versioni canapa, amaranto, espresso o nera, oppure talco nella versione talco. Il mobile è disponibile nella versione a cinque o a sette ripiani.

Rotating shelf bookcase

Uprights and shelves in medium density fiberboard, finished with scratch-resistant embossing in the shades talc, hemp, amaranth, espresso or black. Steel articulated joint in the shade black for the models hemp, amaranth, espresso, black or in the shade talc for the talc model. The shelf unit is available with either five or seven shelves.

Bibliothèque avec étagères pivotantes

Éléments en medium density fiberboard avec vernissage gaufré anti-rayures dans couleurs talc, chanvre, rouge amarante, espresso ou noire. Articulation en acier verni noir dans les versions chanvre, rouge amarante, espresso, noire, ou verni talc pour la version talc. Le meuble est disponible dans la version avec cinq ou sept étagères.

Bücherregal mit Drehregalen

Platten aus Medium Density Fiberboard, kratzfest gaufriert lackiert in den Farben Talkum, Hanf, Amarantröt, Espresso oder schwarz. Verbindungsstück aus schwarz-lackiertem Stahl für die Modelle in den Farben Hanf, Amarantröt, Espresso, schwarz, oder Talkum-lackiert für die Talkum-Version. Das Drehregal ist in zwei Versionen lieferbar, bzw. mit fünf oder sieben Platten.

Biblioteca con estantes giratorios

Estantes de MDF lacado en relieve anti-rasguño en los colores talco, cañamo, granate, espresso o negro. Articulación de acero pintado negro por las versiones en cañamo, granate, espresso, negro o talco por la versión en talco. El mueble está disponible con cinco o siete estantes.

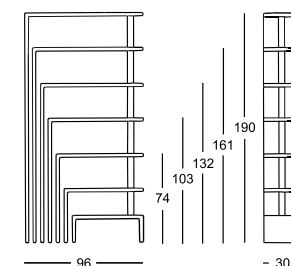

Snodo/Articulated joint/Articulacion/Verbindungsstück/Articulación



Piani/Shelves/Plateaux/Platten/Estantes





Design

Achille e Pier Giacomo Castiglioni

1957

Sgabello

Gambo in acciaio cromato. Sedile verniciato nei colori: arancio, rosso, giallo, bianco o nero. Base in faggio evaporato, colore naturale.

Stool

Chromium-plated steel stem. Seat lacquered in the colours: orange, red, yellow, white or black. Footrest in steam-treated beech, natural colour.

Tabouret

Pied en acier chromé. Siège verni dans les couleurs: orange, rouge, jaune, blanc ou noir. Base en hêtre évaporé, couleur naturelle.

Hocker

Stützstange aus verchromtem Stahl. Sitz lackiert orange, rot, gelb, weiß oder schwarz. Fuß aus gedampfter Buche, naturfarben.

Taburete

Pata de acero cromado. Asiento pintado en los colores: rojo, naranja, amarillo, blanco o negro. Base de haya vaporizada, color natural.

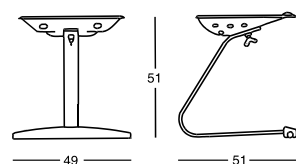

Design

Enzo Mari

1991

Appendiabiti a muro

Elemento singolo in acciaio verniciato antigraffio, colore talco o nero.

Coat hanger

Single steel element painted talc or black with scratch resistant finish.

Porte-manteaux a mur

Élément single en acier verni anti-rayures, couleur talc ou noire.

Wandgarderobe

Einzelelement aus Stahl mit Anti-Kratzer-Lackierung, Farbe Talkum oder schwarz.

Perchero de pared

Elemento colgador de acero, lacado con relieve antirasguño de color talco o negro.

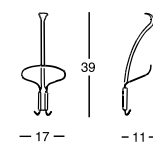



Design

Achille Castiglioni

1970

Sedile inginocchiato
Struttura in poliuretano rigido. Basamento in polistirolo, colore nero. Imbottitura in poliuretano flessibile. Gambo in acciaio inox 18/8. Rivestimento in Ecofire o pelle 95.

Kneeling-stool
Stiff polyurethane frame. Base in black painted polystyrene. Flexible polyurethane upholstery. 18/8 stainless steel leg. Cover in Ecofire or leather 95.

Siège-agenouilleur
Structure en polyuréthane rigide. Embase en polystyrène, couleur noire. Rembourrage en polyuréthane flexible. Tige en acier inox 18/8. Revêtement en Ecofire ou cuir 95.

Kniesitz
Gestell aus steifem Polyurethan. Basis aus schwarzem Polystyrol. Polsterung aus flexiblem Polyurethan. Stützstange aus Inox-Stahl 18/8. Bezug aus Ecofire oder Leder 95.

Asiento ergonómico
Estructura de poliuretano rígido. Base de poliestirol, de color negro. Acolchado de poliuretano flexible. Elemento de soporte asiento de acero inox 18/8. Tapizado en Ecofire o piel 95.

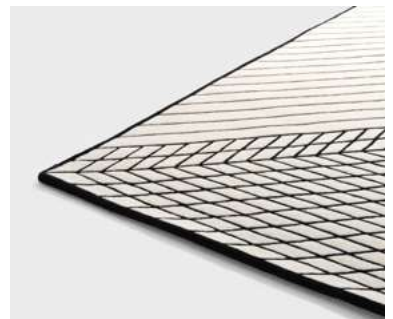
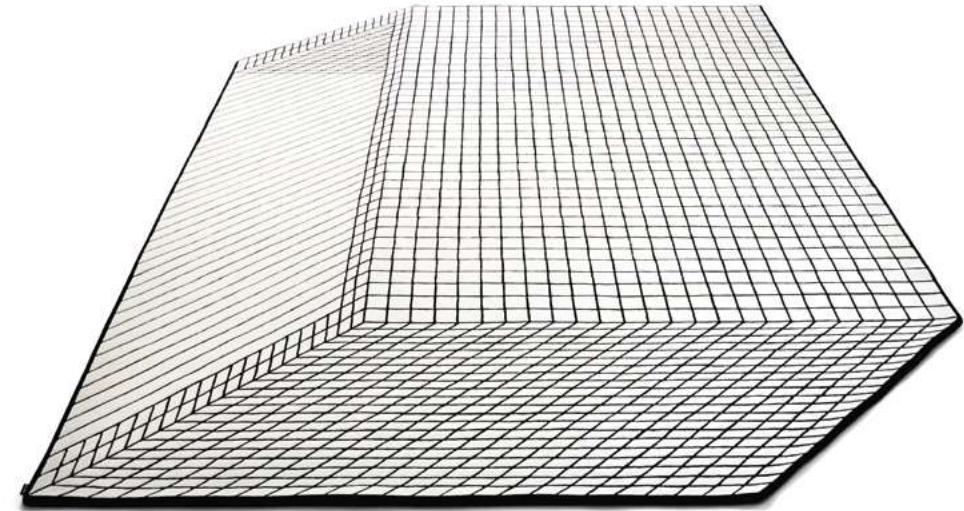
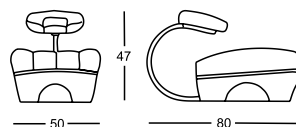

Design

Superstudio / Cristiano Toraldo di Francia

1969-1972

Tappeto
Tappeto tuftato a mano con vello uniforme su tutta la superficie realizzato in 100% lana neozelandese. Supporto inferiore in tela 100% cotone fissata con colla in lattice 100% naturale. Bordatura perimetrale eseguita a mano con filo di lana a rifinire i sei lati. Disponibile nella dimensione 200x300 e 250x350 cm in un unico colore: fondo bianco e linee grigie e nere in linea con il disegno originale.

Carpet
Hand-tufted carpet with uniform fleece over the entire surface made of 100% New Zealand wool. Perimeter edging finished by hand with wool thread on all six sides. Available in sizes 200x300 cm and 250x350 cm in a single colour scheme: white background and gray and black lines compliant with the original design.

Tapis
Tapis tufté à la main avec toison uniforme sur toute la surface en laine 100% néo-zélandaise. Ordure périmétrique réalisée à la main avec du fil de laine pour finir les six côtés. Disponible en tailles 200x300 et 250x350 cm en une seule couleur: fond blanc et lignes grises et noires en ligne avec le design original.

Teppich
Handgetufteter Teppich mit einheitlichem Vlies über die gesamte Fläche aus 100% neuseeländischer Wolle. Umfangseinfassung von Hand mit Wollfaden, um die sechs Seiten zu beenden. Erhältlich in den Größen 200x300 und 250x350 cm in einer einzigen Farbe: weißer Hintergrund und graue und schwarze Linien im Einklang mit dem ursprünglichen Design.

Alfombra
Alfombra con copetes a mano con vellón uniforme sobre toda la superficie hecha de lana 100% neozelandesa. Soporte inferior en lona 100% algodón fijada con pegamento de látex 100% natural. Borde perimetral realizado a mano con hilo de lana para terminar los seis lados. Disponible en tamaños 200x300 y 250x350 cm en un solo color: fondo blanco y líneas grises y negras en línea con el diseño original.

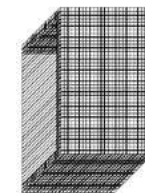

Dimensioni/
Sizes/
Dimensions/
Abmessungen/
Medidas

200 x 300 cm
250 x 350 cm

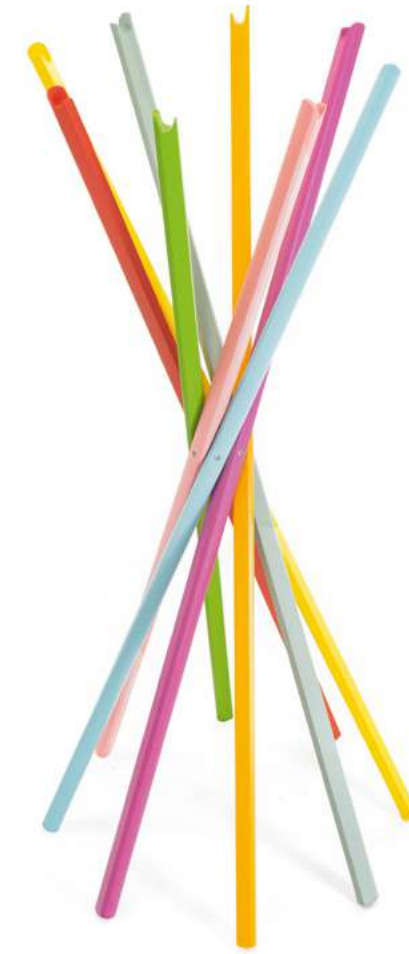

Design

De Pas, D'Urbino, Lomazzi

1973

Appendiabiti chiudibile e regolabile

Struttura in frassino tinto rovere, tinto grigio, talco, nero o amaranto.

Folding and adjustable clothes stand

Frame in natural, grey, talc, black or amaranth varnished ash.

Portemanteau pliant et réglable

Structure en frêne teinté rouvre, teinté gris, talc, noir ou rouge amarante.

Zusammenfaltbarer und verstellbarer Kleiderständer

Gestell aus Esche, Eichenfarben oder grau, Talkum, schwarz oder amarantrot gebeizt.

Perchero plegable y arreglable

Estructura de fresno teñido roble, gris, talco, negro o granate.

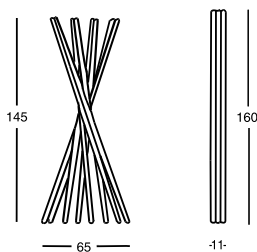

Struttura/Frame/Structure/ Gestell/Estructura

Frassino tinto nero/Black varnished ash/ Frêne teinté noir/Schwarz-gebeizte Esche/ Fresno teñido negro



Frassino tinto grigio/Grey varnished ash/ Frêne teinté gris/ Grau-gebeizte Esche/ Fresno teñido gris



Frassino tinto talco/Talc varnished ash/ Frêne teinté talc/ Talkum-gebeizte Esche/ Fresno teñido talco



Frassino tinto rovere/ Oak varnished ash/ Frêne teinté rouvre/Eiche gebeizte Esche/ Fresno teñido roble



Frassino tinto amaranto/ Amaranth varnished ash/ Frêne teinté rouge amarante/ Amarantrot-gebeizte Esche/ Fresno teñido granate



Design

De Pas, D'Urbino, Lomazzi

1973-2023

Appendiabiti chiudibile e regolabile

Struttura in faggio laccata multicolore. Edizione numerata.

Folding and adjustable clothes-stand

Multicoloured lacquered beech frame. Numbered edition.

Portemanteaux pliant et réglable

Structure en hêtre laqué multi-couleur. Édition numérotée.

Zusammenfaltbarer und verstellbarer Kleiderständer

Gestell aus mehrfarbig lackierter Buche. Nummerierte Auflage.

Perchero plegable y arreglable

Estructura de haya lacada multicolor. Edición numerada.

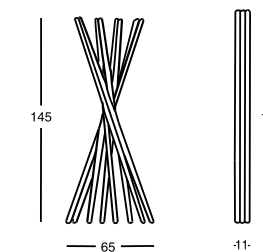



Design

Achille e Pier Giacomo Castiglioni

1957

Sedile

Sella di bicicletta da corsa, colore nero, asta in acciaio verniciato, colore rosa. Basamento in fusione di ghisa.

Seat

Black saddle of racing bicycle, pink lacquered steel column. Cast-iron base.

Siège

Selle de bicyclette de course couleur noire. Tige en acier verni couleur rose. Base en fonte.

Sitz

Rennradsattel Farbe schwarz. Stützstange aus lackiertem Stahl, rosa. Fuß aus Gusseisen.

Taburete

Sillín de bicicleta de carrera de color negro, vástago de acero pintado de rosa. Base en hierro fundido.

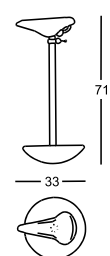

Design

Achille Castiglioni

della serie Servi di Achille & Pier Giacomo Castiglioni

1986

Paravento

Base in polipropilene verniciato talco, amaranth o nero. Asta di sostegno in acciaio verniciato, colore talco, amaranth o nero. Telo in panno di lana, misure cm 66 x 150, nei colori: grigio chiaro, grigio medio, grigio scuro, rosso, giallo, carta da zucchero, mattone, verde chiaro, verde scuro o viola.

Screen

Base in talc, amaranth or black painted polypropylene. Steel support rod, painted in talc, amaranth or black. Wool canvas screen, sizes cm 66 x 150, in the shades: light grey, medium grey, dark grey, red, yellow, powder blue, brick, light green, dark green or purple.

Paravent

Base en polypropylène verni talc, rouge amarante ou noir. Tige de soutien en acier verni talc, rouge amarante ou noir. Toile en tissu de laine, mesure 66 x 150 cm, dans les couleurs : gris clair, gris moyen, gris foncé, rouge, jaune, bleu poudre, brique, vert clair, vert foncé ou violet.

Paravent

Fuß aus Talkum, amaranthrot oder schwarz lackiertem Polypropylen. Stange aus lackiertem Stahl, in den Farben Talkum, amaranthrot oder schwarz. Leinwand aus Wolle, Maße 66 x 150 cm, in den Farben: hellgrau, mittelgrau, dunkelgrau, rot, gelb, taubenblau, Backstein, hellgrün, dunkelgrün oder Veichen.

Separador de ambiente

Base de polipropileno pintado talco, granate o negro. Asta de soporte de acero pintado talco, granate o negro. Panel en tejido de lana, medida 66 x 150 cm, en los colores: gris claro, gris medio, gris oscuro, rojo, amarillo, azul polvo, ladrillo, verde claro, verde oscuro o púrpura.

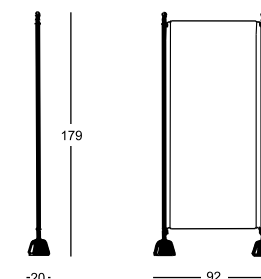

Vello

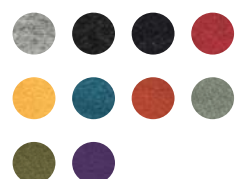

Base/Base/Base/Fuß/Base



Servonotte ³⁵⁰ Servietto ³⁵⁵

NEW FINISHES

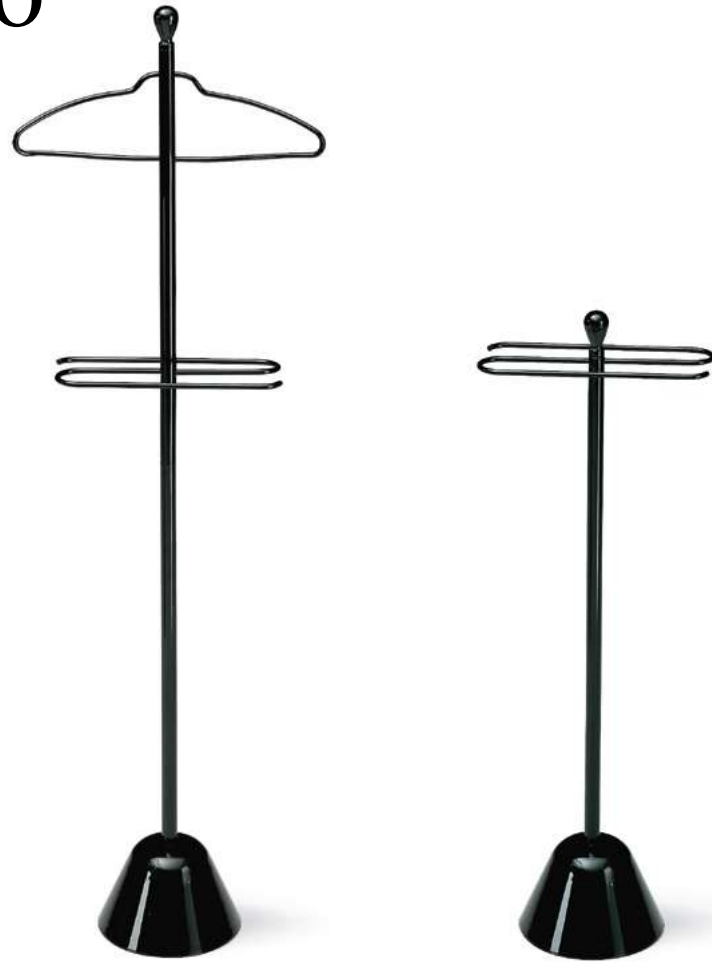

Design

Achille Castiglioni della serie Servi di Achille & Pier Giacomo Castiglioni 1986

Portabito/ Portasciugamani

Base in polipropilene e struttura verniciate in acciaio, colore talco o nero.

Clothes-stand/Towel-rack

Polypropylene base and steel frame, painted in the colours: talc or black.

Valet de chambre/ porte-serviettes

Base en polypropylène et structure en acier verni, couleur talc ou noire.

Stummer Diener/ Handtuchträger

Fuß aus Polypropylen und Gestell aus lackiertem Stahl, Talkum oder schwarz.

Galán de noche/ porta toallas

Base de polipropileno y estructura de acero pintado en los colores: talco o negro.

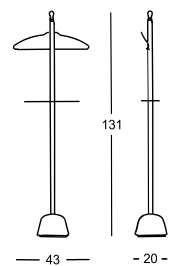

350

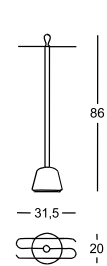

355



Servobandiera ⁵¹⁵



Design

Achille Castiglioni della serie Servi di Achille & Pier Giacomo Castiglioni 1986

IN/OUT

Portabandiera

Base in polipropilene verniciato nero. Asta di sostegno in acciaio verniciato, colore nero per esterni. Bandiera in stamigna di lana. Colori, simboli e misure da capitolato. Misura del drappo cm 100 x 150. La bandiera svizzera misura cm 100 x 100. I simboli delle bandiere statunitensi e Consiglio d'Europa sono ricamati. Disponibile anche la sola base e asta senza drappo.

Flag-holder

Base in black painted polypropylene. Steel support rod, in the shade black for outdoor. Bunting flag. Regulation colours, symbols and sizes. Flag size cm 100 x 150, Swiss flag cm 100 x 100. On the USA and Council of Europe flags, the symbols are embroidered. Base and support rod, without cloth, are available separately.

Porte-étendard

Base en polypropylène verni noir. Tige de soutien en acier verni couleur noire pour extérieurs. Drapeau en étamine de laine. Couleurs, symboles et mesures suivant cahier de charges. Dimensions du drapeau cm 100 x 150. Le drapeau suisse mesure cm 100 x 100. Les symboles des drapeaux américain et du Conseil d'Europe sont brodés. Nous pouvons fournir la base et la tige de soutien, sans le drapeau.

Fahnenständer

Fuß aus Polypropylen, schwarz lackiert. Stange aus Stahl, schwarz lackiert fürs Freie. Fahne aus Wolletamin. Genormte Farben, Symbole und Maße. Maße 100 x 150 cm. Maße der Schweizer Fahne 100 x 100 cm. Die Symbole Europarats und der USA sind aufgestickt. Fuß und Stange auch ohne Fahne lieferbar.

Portabandera

Base de polipropileno pintado negro. Asta de acero pintado de negro para exteriores. Bandera de lana. Colores, símbolos y medidas según las normas. Medidas de la bandera 100 x 150 cm. Los símbolos de las banderas estadounidense y del Consejo de Europa están bordados. También suministramos solamente la base y el asta, sin bandera.

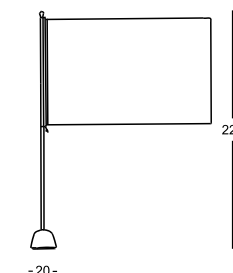

-20-

Servofumo ³⁷⁰

Servopluvio ³⁸⁰



Design

Achille e Pier Giacomo Castiglioni

1961

IN/OUT

Portacenere/portaombrelli
Base in polipropilene, vaschetta in alluminio e struttura di sostegno in acciaio verniciato, colore nero per esterni.

Ashtray/umbrella stand
Base in polypropylene, container in aluminium and steel support frame, black painted for outdoor.

Cendrier/porte-parapluies
Base en polypropylène, bassinet en aluminium et structure de soutien en acier verni couleur noire pour extérieurs.

Standascher/Regenschirmständer
Fuß aus Polypropylen, Behälter aus Aluminium und tragendes Gestell aus lackiertem Stahl, schwarzfarben fürs Freie.

Cenicero/paragüero
Base de polipropileno, cubeta de aluminio y estructura de acero pintado, color negro para exteriores.

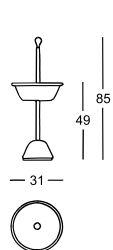

370/B

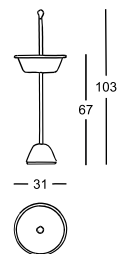

370/A

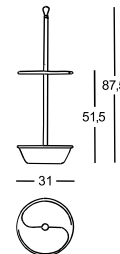

380

Servomanto ³⁰⁵

NEW FINISHES

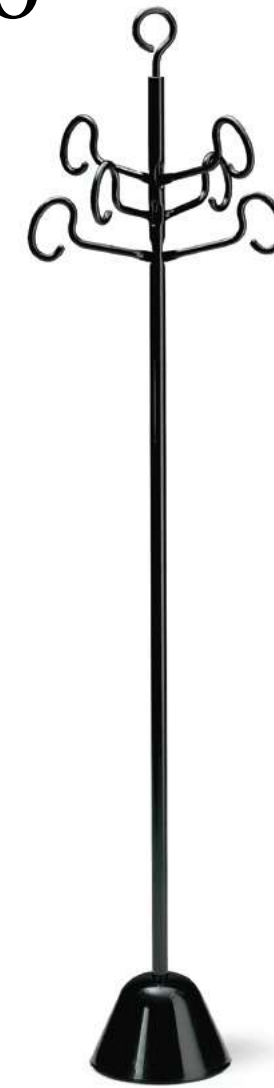

Design

Achille Castiglioni

della serie Servi di Achille & Pier Giacomo Castiglioni

1985

Appendiabiti
Base in polipropilene verniciato talco o nero. Asta di sostegno e bracci appendiabiti in acciaio verniciato, colore talco o nero.

Clothes stand
Base in talc or black painted polypropylene. Support rod and arms in talc or black painted steel.

Portemanteaux
Base en polypropylène verni talc ou noir. Tige de soutien et bras en acier verni talc ou noir.

Kleiderständer
Fuß aus Polypropylen, Talkum oder schwarz lackiert. Stützstange und Arme aus Talkum- oder schwarz lackiertem Stahl.

Perchero
Base de polipropileno pintado talco o negro. Estructura de acero pintado, color talco o negro.

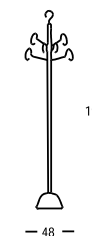

305





Design

Achille Castiglioni della serie Servi di Achille & Pier Giacomo Castiglioni 1984

Transenna

Base in polipropilene verniciato nero. Asta di sostegno con gancio in acciaio verniciato, colore nero. Catena in acciaio verniciato rosso.

Partition system

Base in black painted polypropylene. Black painted steel support rod with hook. Red painted steel chain.

Transenne

Base en polypropylène verni noir. Tige de soutien avec crochet en acier verni noir. Chaîne en acier verni rouge.

Absperrsystem

Fuß aus Polypropylen, schwarz lackiert. Stange mit Haken aus schwarz lackiertem Stahl. Kette aus rot lackiertem Stahl.

Catenaria

Base de polipropileno pintado negro. Asta de soporte con gancho de acero pintado de negro. Cadena de acero barnizado rojo.

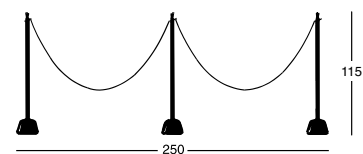

Tappeto

Tappeto annodato a mano realizzato in 100% lana neozelandese. Bordatura perimetrale, eseguita a mano, con filo di lana. Lo spessore complessivo del tappeto è di circa 22 mm ed il peso è di 3,8 Kg/mq. Colori arancione, canapa o espresso.

Carpet

Hand-knotted carpet made of 100% New Zealand wool. Hand-knotted perimeter edging with wool yarn. The overall thickness of the carpet is approx. 22 mm and the weight is 3.8 kg/sqm. Colours orange, hemp or espresso.

Tapis

Tapis noué à la main en 100% laine néo-zélandaise. Bordure périmétrique nouée à la main avec du fil de laine. L'épaisseur totale du tapis est d'environ 22 mm et son poids est de 3,8 kg/m². Coloris orange, chanvre ou espresso.

Teppich

Handgeknüpfter Teppich aus 100% neuseeländischer Wolle. Handgeknüpfte Randeinfassung mit Wollgarn. Die Gesamtdicke des Teppichs beträgt ca. 22 mm und das Gewicht 3,8 kg/qm. Farben orange, hanf oder espresso.

Alfombra

Alfombra anudada a mano con lana 100% de Nueva Zelanda. Borde perimetral anudado a mano con hilo de lana. El grosor total de la alfombra es de aproximadamente 22 mm y el peso es de 3,8 kg/m². Colores naranja, cáñamo o espresso.

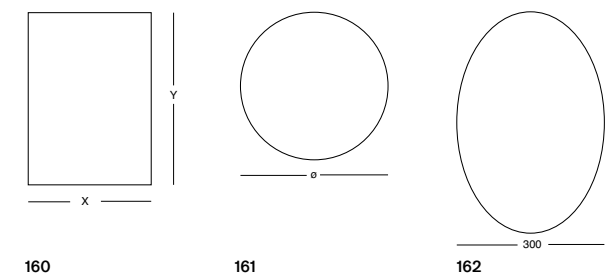

Dimensioni/Sizes/Dimensions/Abmessungen/Medidas

200x300 cm / 250x350 cm
Ø 300 cm / Ø 350 cm
300x450 cm



Contenitori
Sideboards
Container
Sideboard
Muebles
contenedores

Quaderna Cupboard ⁷⁵⁷



Design

Superstudio

1969-1972

Madia

Struttura in legno placcato laminato Print, colore bianco, a stampa digitale a quadretti neri con interasse di 3 cm. Placcatura interna in laminato colore nero. Ripiani interni regolabili in cristallo temperato.

Cupboard

Honeycomb core structure coated with white Print laminate, digitally printed with black squares at 3 cm spacing. Internal black laminate plating. Adjustable internal shelves in tempered plate glass.

Armoire

Structure en panneau alvéolaire plaqué en laminé Print couleur blanche, imprimé en digital à carrés noirs avec entraxe de 3 cm. Revêtement intérieur en stratifié noir. Plateaux intérieurs réglables en verre trempé.

Schrank

Gestell aus Sperrholz mit weißem Print Laminat belegt. Digitaldruck mit kariertem Muster, Linienabstand 3 cm. Innen mit schwarzem Laminat überzogen. Verstellbare innere Regale aus gehärtetem Kristallglas.

Aparador

Estructura de madera aplacada con laminado Print, color blanco, a impresión digital en cuadrillos negros de 3 cm. Al interior esta chapado en laminado negro. Estantes interiores regulables de cristal templado.

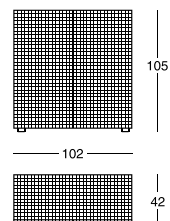

Quaderna Sideboard ⁷⁵⁶

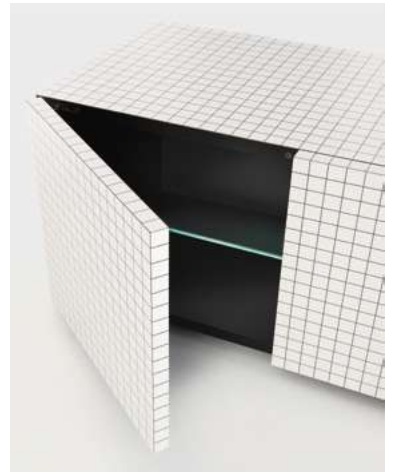

Design

Superstudio

1969-1972

Contentitore

Struttura in legno placcato laminato Print, colore bianco, a stampa digitale a quadretti neri con interasse di 3 cm. Placcatura interna in laminato colore nero. Ripiani interni regolabili in cristallo temperato. Sullo schienale, il contenitore è dotato di aperture passacavi.

Sideboard

Honeycomb core structure coated with white Print laminate, digitally printed with black squares at 3 cm spacing. Internal black laminate plating. Adjustable internal shelves in tempered plate glass. On the back panel, the sideboard is equipped with cable entries.

Container de rangement

Structure en panneau alvéolaire plaqué en laminé Print couleur blanche, imprimé en digital à carrés noirs avec entraxe de 3 cm. Revêtement intérieur en stratifié noir. Plateaux intérieurs réglables en verre trempé. Sur le panneau arrière, le container est équipé des ouvertures pour câbles.

Sideboard

Gestell aus Sperrholz mit weißem Print Laminat belegt. Digitaldruck mit kariertem Muster, Linienabstand 3 cm. Innen mit schwarzem Laminat überzogen. Verstellbare innere Regale aus gehärtetem Kristallglas. Auf der Rückseite ist das Sideboard mit Öffnungen für Kabeldurchführung verstattet.

Mueble contenedor

Estructura de madera aplacada con laminado Print, color blanco, a impresión digital en cuadrillos negros de 3 cm. Al interior esta chapado en laminado negro. Estantes interiores regulables de cristal templado. En el panel trasero, el contenedor está equipado de agujeros de entrada para cables.

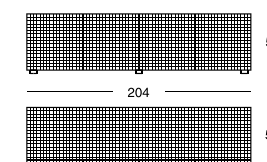

Z24 Cupboard ⁷²⁶

NEW PRODUCT



Design

Muller Van Severen

2024

Madia

Struttura in MDF e legno listellare, laccatura opaca nei colori talco, cera, canapa, caramello, arancione, amaranth, verde prato, espresso e nero. Ripiani interni regolabili in cristallo temperato. A richiesta è possibile all'interno del vano integrare una fonte luminosa a led a luce neutra.

Cupboard

Frame in MDF and blockboard wood, matt lacquered in the colours talc, wax, hemp, caramel, orange, amaranth, grass green, espresso and black. Adjustable internal shelves in tempered plate glass. On request, it is possible to integrate a neutral LED light source inside the cupboard.

Armoire

Structure en MDF et bois à lamelles, laquée mat dans les couleurs talc, cire, chanvre, caramel, orange, rouge amarante, vert pré, espresso et noir. Plateaux intérieurs réglables en verre trempé. Sur demande, il est possible d'intégrer une source de lumière LED neutre à l'intérieur de l'armoire.

Schrank

Gestell aus MDF und Lattenholz matt lackiert in den Farben Talkum, Wachs, Hanf, Karamell, Orange, Amaranth, grasgrün, Espresso und schwarz. Verstellbare innere Regale aus gehärtetem Kristallglas. Auf Anfrage ist es möglich, eine neutrale LED-Lichtquelle im Schrank zu integrieren.

Aparador

Estructura de MDF y listones de madera, lacada mate en los colores talco, cera, cáñamo, caramelo, naranja, granate, verde prado, espresso y negro. Estantes interiores regulables de cristal templado. Sobre pedido, es posible integrar una fuente de luz LED neutra en el interior de l'aparador.

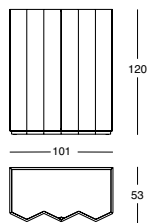

Struttura/Frame/Structure/ Gestell/Estructura



Z24 Sideboard ⁷²⁷

NEW PRODUCT

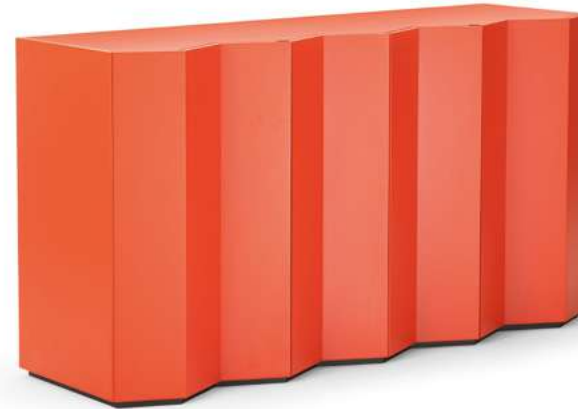

Design

Muller Van Severen

2024

Contenitore

Struttura in MDF e legno listellare, laccatura opaca nei colori talco, cera, canapa, caramello, arancione, amaranth, verde prato, espresso e nero. Ripiani interni regolabili in cristallo temperato. A richiesta è possibile all'interno del vano integrare una fonte luminosa a led a luce neutra.

Storage unit

Frame in MDF and blockboard wood, matt lacquered in the colours talc, wax, hemp, caramel, orange, amaranth, grass green, espresso and black. Adjustable internal shelves in tempered plate glass. On request, it is possible to integrate a neutral LED light source inside the storage unit.

Container de rangement

Structure en MDF et bois à lamelles, laquée mat dans les couleurs talc, cire, chanvre, caramel, orange, rouge amarante, vert pré, espresso et noir. Plateaux intérieurs réglables en verre trempé. Sur demande, il est possible d'intégrer une source de lumière LED neutre à l'intérieur del container.

Sideboard

Gestell aus MDF und Lattenholz matt lackiert in den Farben Talkum, Wachs, Hanf, Karamell, Orange, Amaranth, grasgrün, Espresso und schwarz. Verstellbare innere Regale aus gehärtetem Kristallglas. Auf Anfrage ist es möglich, eine neutrale LED-Lichtquelle im Sideboard zu integrieren.

Mueble contenedor

Estructura de MDF y listones de madera, lacada mate en los colores talco, cera, cáñamo, caramelo, naranja, granate, verde prado, espresso y negro. Estantes interiores regulables de cristal templado. Sobre pedido, es posible integrar una fuente de luz LED neutra en el interior del mueble.

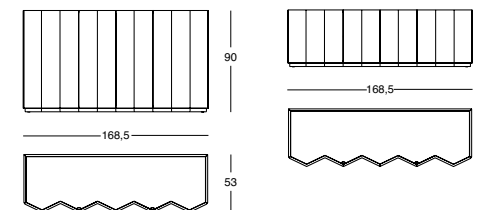

Struttura/Frame/Structure/ Gestell/Estructura



Specchi
Mirrors
Miroirs
Spiegel
Espejos

Milo CM ⁴⁶⁵



Omaggio a

Carlo Mollino

1938

Specchio

Silhouette della Venere di Milo in cristallo con noddolino in acciaio inox per il fissaggio a parete.

Mirror

Venus de Milo's silhouette plate glass, with stainless steel pawl for hanging.

Miroir

Silhouette de la Venus de Milo en verre avec attache en acier inox pour l'accrochage au mur.

Spiegel

Silhouette der Venus von Milo aus Kristallglas. Aufhängung aus Inox-Stahl.

Espejo

Silueta de la Venus de Milo de cristal con pletinas de acero inox para colgar el espejo a la pared.



Quaderna Mirror ⁴⁷⁶

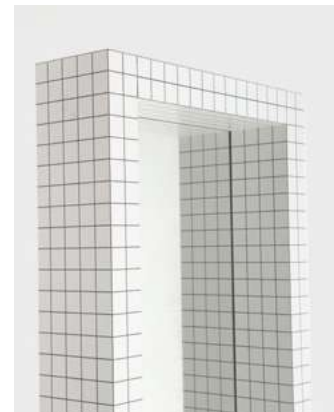
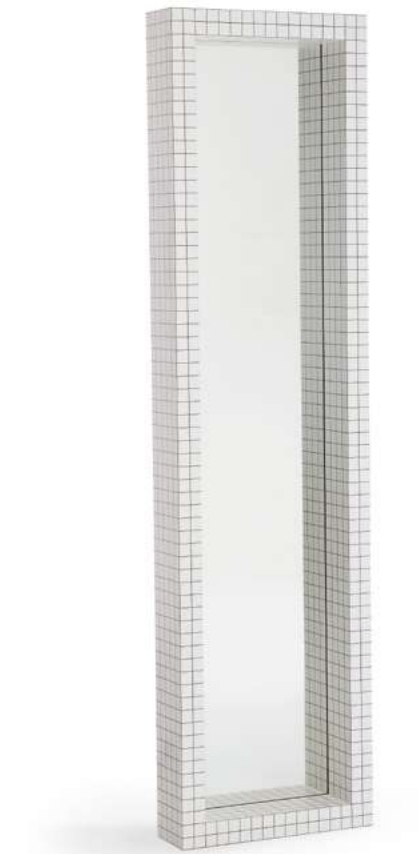

Design

Superstudio

1969-1972

Specchio

Cristallo spessore 5 mm. Cornice in legno placcato laminato Print, colore bianco, a stampa digitale a quadretti neri con interasse di 3 cm.

Mirror

5mm thick plate glass. Honeycomb core frame coated with white Print laminate, digitally printed with black squares at 3 cm spacing.

Miroir

Cristal de 5 mm d'épaisseur. Cadre en panneau alvéolaire plaqué en laminé Print, couleur blanche, imprimé en digital à carrés noirs avec entraxe de 3 cm.

Spiegel

5 mm. starkes Kristallglas. Rahmen aus Sperrholz mit weißem Print Laminat belegt. Digitaldruck mit kariertem Muster, Linienabstand 3 cm.

Espejo

Cristal, 5 mm de espesor. Marco de madera aplacada con laminado Print, color blanco, a impresión digital en cuadritos negros de 3 cm.

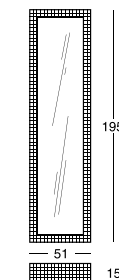

Raperonzolo ⁴⁷¹



Design

Atelier Oi

2015

Specchio
Superficie in cristallo. Il bordo dello specchio è in cuoio intrecciato colore gold accoppiato ad Alcantara® nei colori gold, blu e melanzana. Il fissaggio a parete è realizzato con una piastra in metallo bronzato.

Mirror
Plate glass surface. The mirror outline is made of cowhide in the shade of gold, interwoven with Alcantara® in the shades gold, blue and aubergine. Wall fastening by means of a bronzed metal plate.

Miroir
Surface en cristal. Le bord du miroir est en cuir sellier tressé dans la couleur gold couplé au Alcantara® dans les couleurs gold, bleu et aubergine. L'accrochage au mur est prévu à travers une plaque en métal bronzée.

Spiegel
Fläche aus Glasscheiben. Der Spiegel ist mit einem Zopf aus goldfarbenen Kernlederbänder umfasst, welche mit Alcantara® bzw. in den Farben Gold, Blau und Aubergine geflochten werden. Befestigung an der Wand mittels einer Platte aus bronziertem Metall.

Espejo
Superficie en cristal. El borde del espejo es en cuero trenzado en color gold acoplado con Alcantara® en los colores gold, azul y berenjena. Para colgar el espejo a la pared está prevista una placa en metal bronceado.

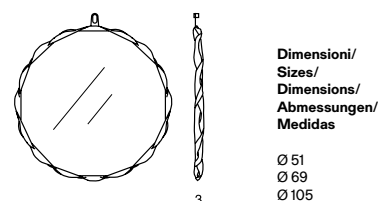

Dimensioni/
Sizes/
Dimensions/
Abmessungen/
Medidas

Ø 51
Ø 69
Ø 105

Sosia ⁸⁸⁵⁸

NEW PRODUCT



Design

Ugo La Pietra

1982

Specchio
Cristallo extra chiaro bisellato, decorato con stampa digitale, retro argentato. A richiesta è possibile, nella parte posteriore dello specchio, integrare una fonte luminosa a led a luce calda.

Mirror
Extra clear bevelled plate glass, decorated with digital printing, silver back. On request, it is possible to integrate a neutral warm LED light source at the rear of the mirror.

Miroir
Cristal extra clair biseauté, décoré avec impression digital, dos argenté. Sur demande, il est possible d'intégrer une source de lumière chaude LED à l'arrière du miroir.

Spiegel
Extra klares schräg-abgeschliffenes Kristallglas, mit Digitaldruck, silberne Rückseite. Auf Anfrage ist es möglich, eine warme LED-Lichtquelle auf der Rückseite des Spiegels zu integrieren.

Espejo
Cristal extra claro biselado, decorado con impresión digital, parte trasera plateada. Sobre pedido, es posible integrar una fuente de luz LED cálida en la parte trasera del espejo.

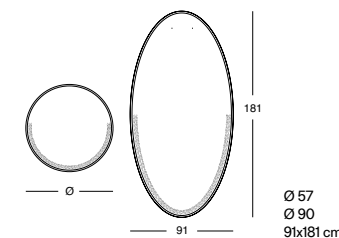

Ø 57
Ø 90
91x181 cm

Finiture/Finishes

Verniciatura Metallizzata/Metallic Varnish/Peinture Metallise/Metallic Lackierung/Pintura Metalizada

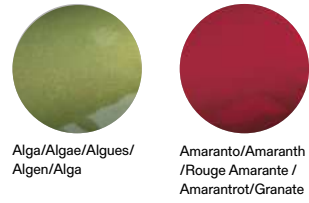

Alga/Algae/Algues/
Algen/Alga

Amaranto/Amaranth
/Rouge Amaranth /
Amarantrot/Granate



Caramello/Caramel/
Caramel/Karamell/
Caramelo

Espresso/Espresso/
Espresso/Espresso/
Espresso

Nichelsatinatura/Nickel-satin finish/Nickelage satiné/Vernickeltes Finish/Niquelado satinado



Naturale opaca/Matt
natural/Naturel mat/
Naturfarben mattiert
/Natural mate

Nera opaca/Matt
black/Noir mat/
Schwarz mattiert/
Negro mate

Cristallo/Plate glass/Verre/Kristallglas/Cristal

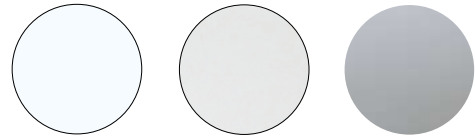

Cristallo trasparente/
Clear plate glass/
Verre transparent/
Klares Kristallglas/
Cristal transparente

Cristallo extra chiaro
trasparente/Extra-clear
plate glass/Verre extra-
clair transparent/Extra
klares Kristallglas/Cristal
extraclaro transparente

Cristallo fumé/Smoky
grey plate glass/
Verre fumé gris/
Gruu rauchfarbenes
Kristallglas/Cristal
gris humo

Verniciatura Lucida/Glossy Varnish/Laquer Brillant/Glanzlackierung/Lacado Brillante

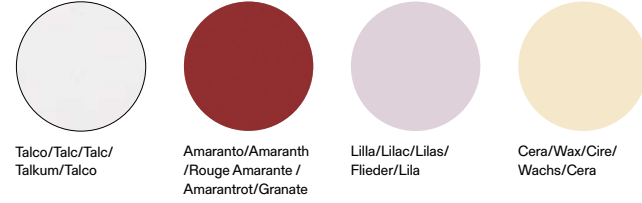

Talco/Talc/Talc/
Talkum/Talco

Amaranto/Amaranth
/Rouge Amaranth /
Amarantrot/Granate

Lilla/Lilac/Lilas/
Flieder/Lila

Cera/Wax/Cire/
Wachs/Cera

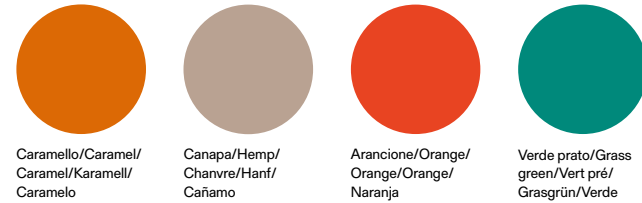

Caramello/Caramel/
Caramel/Karamell/
Caramelo

Canapa/Hemp/
Chanvre/Hanf/
Cañamo

Arancione/Orange/
Orange/Orange/
Naranja

Verde prato/Grass
green/Vert pré/
Grasgrün/Verde
prado

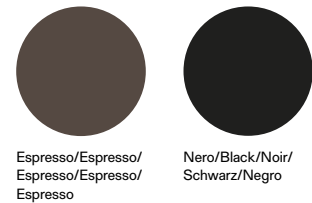

Espresso/Espresso/
Espresso/Espresso/
Espresso

Nero/Black/Noir/
Schwarz/Negro

Laminato/Laminate/Laminé/Laminat/Laminado

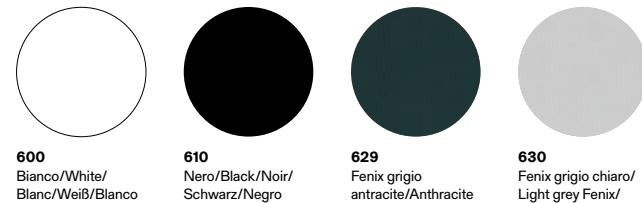

600
Bianco/White/
Blanc/Weiß/Bianco

610
Nero/Black/Noir/
Schwarz/Negro

629
Fenix grigio
antracite/Anthracite
grey Fenix/Fenix
gris anthracite/
Anthrazitgrau
Fenix/Fenix gris
antracita

630
Fenix grigio chiaro/
Light grey Fenix/
Fenix gris clair/
Hellgrau
Fenix/
Fenix gris claro

Cemento/Cement/Ciment/Zement/Cemento



Polimex® rivestito in cemento con finitura acrilica/
Polimex® covered with acrylic finish cement/
Polimex® revêtu en ciment avec finition acrylique/
Polimex® mit Zement verkleidet und Acryl Finish/
Polimex® revestido en cemento, acabado acrílico

Verniciatura Opaca/Matt Varnish/Peinture Mat/Matte Lackierung/Pintura Mate

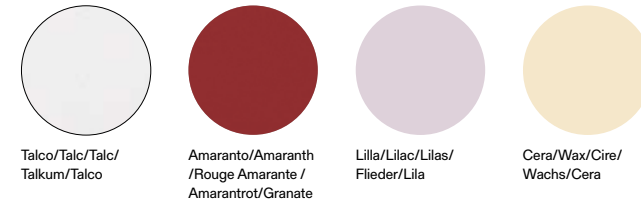

Talco/Talc/Talc/
Talkum/Talco

Amaranto/Amaranth
/Rouge Amaranth /
Amarantrot/Granate

Lilla/Lilac/Lilas/
Flieder/Lila

Cera/Wax/Cire/
Wachs/Cera

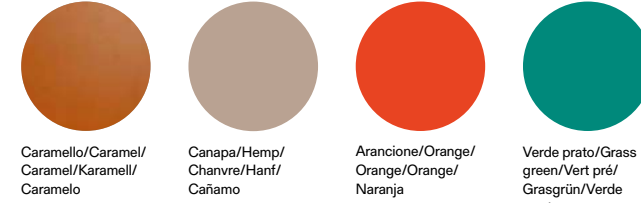

Caramello/Caramel/
Caramel/Karamell/
Caramelo

Canapa/Hemp/
Chanvre/Hanf/
Cañamo

Arancione/Orange/
Orange/Orange/
Naranja

Verde prato/Grass
green/Vert pré/
Grasgrün/Verde
prado

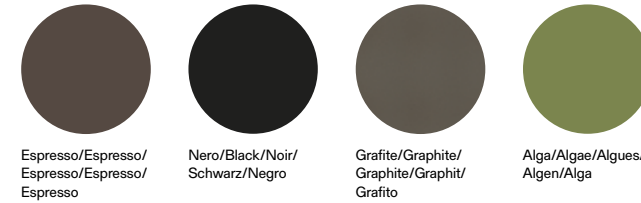

Espresso/Espresso/
Espresso/Espresso/
Espresso

Nero/Black/Noir/
Schwarz/Negro

Grafite/Graphite/
Graphite/Graphit/
Grafito

Alga/Algae/Algues/
Algen/Alga

Essenza legno/Wood finish/Essence du bois/Holzart/Esencia de madera



Acero/Maple/
Érable/Ahorn/Arce

Betulla/Birch/
Bouleau/Birke/
Abedul

Faggio naturale/
Natural beech/
Hêtre naturel/
Naturfarbene Buche
/Haya natural

Faggio evaporato/
Steam-treated
beech/Hêtre
éaporé/Gedampfte
Buche/Haya
vaporizada

Faggio laccato
bianco/White
varnished beech/
Hêtre teinté blanc/
Weiß gebeizte
Buche/Haya teñida
blanco

Faggio laccato
verde/Green
varnished beech/
Hêtre teinté vert/
Grün gebeizte
Buche/Haya teñida
verde

Rovere naturale/
Natural oak/
Rouvre naturel/
Naturfarbene Eiche/
Roble natural

Rovere tinto grigio/
Grey varnished oak/
Rouvre teinté gris/
Gruu gebeizte Eiche/
Roble teñido gris



Rovere tinto nero/
Black varnished oak/
Rouvre teinté noir/
Schwarz gebeizte
Eiche/Roble teñido
negro

Rovere tinto noce
Canaletto/Canaletto
walnut dyed-oak/
Rouvre teinté noyer
Canaletto/Nussbaum
Canaletto-gebeizte
Eiche/Roble teñido
nogal Canaletto

Rovere tinto talco/
Talc varnished oak/
Rouvre teinté talc/
Talkum gebeizte
Eiche/Roble teñido
talc

Frassino tinto grigio/
Grey varnished ash/
Frêne teinté gris/
Gruu gebeiztes
Eschenholz/Fresno
teñido gris

Frassino tinto talco/
Talc varnished ash/
Frêne teinté talc/
Talkum-gebeiztes
Eschenholz/Fresno
teñido talco

Frassino tinto nero/
Black varnished ash/
Frêne teinté noir/
Schwarz gebeiztes
Eschenholz/Fresno
teñido negro

Frassino tinto rovere
naturale/Natural oak
varnished ash/Frêne
teinté rouvre naturel/
Naturfarbene
Eiche gebeiztes
Eschenholz/Fresno
teñido roble natural

Noce Canaletto/
Canaletto walnut/
Noyer Canaletto/
Nussbaum
Canaletto/Nogal
Canaletto

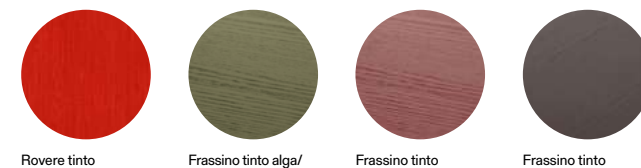

Rovere tinto
arancione/Orange
varnished oak/
Rouvre teinté
orange/Orange-
gebeizte Eiche/
Roble teñido naranja

Frassino tinto alga/
Algae varnished ash/
Frêne teinté algues/
Algen-gebeiztes
Eschenholz/Fresno
teñido alga

Frassino tinto
amaranto/Amaranth
varnished ash/ Frêne
teinté rouge amaranth/
Amarantrot-gebeiztes
Eschenholz/Fresno
teñido granate

Frassino tinto
espresso/Espresso
varnished ash/ Frêne
teinté espresso/
Espresso-gebeiztes
Eschenholz/Fresno
teñido espresso

Marmo/Marble/Marbre/Marmor/Marmól + Pietra/Stone/Pierre/Stein/Piedra



Calacatta grigio/
Grey Calacatta /
Gris Calacatta/
Gruu Calacatta/Gris
Calacatta

Bianco di Carrara/
White Carrara/
Blanc Carrara/Weiß
Carrara/Bianco
Carrara

Emperador

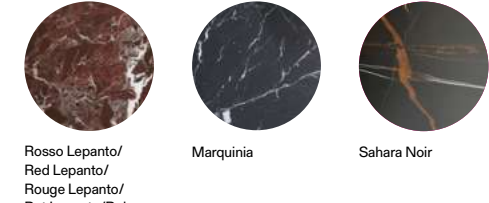

Rosso Lepanto/
Red Lepanto/
Rouge Lepanto/
Rot Lepanto/Rojo
Lepanto

Marquina

Sahara Noir

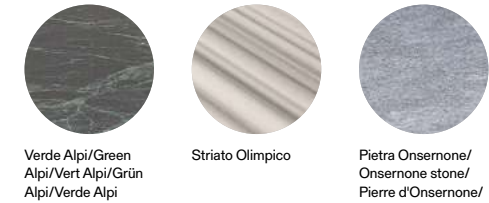

Verde Alpi/Green
Alpi/Vert Alpi/Grün
Alpi/Verde Alpi

Striato Olimpico

Pietra Onsernone/
Onsernone stone/
Pierre d'Onsernone/
Onsernone-Stein/
Piedra Onsernone

zanotta:



Zanotta è membro di Fondazione Altgamma che, dal 1992, riunisce i marchi dell'eccellenza italiana famosi a livello internazionale.

Zanotta is member of the Altgamma Foundation which, since 1992, has gathered together high-end Italian brands famous at international level.



Zanotta è certificata secondo le norme internazionali UNI EN ISO 9001 per i sistemi di gestione per la qualità e UNI ISO 45001 per la sicurezza e salute sui luoghi di lavoro.

Zanotta is certified according to international standards UNI EN ISO 9001 for the quality management systems and UNI ISO 45001 for the safety and health in the workplace.

Zanotta spa si riserva di apportare, senza preavviso, modifiche nei materiali, nei rivestimenti, nelle finiture e nei disegni dei prodotti presentati in questo catalogo. Le texture ed i colori dei materiali e delle finiture hanno valore indicativo in quanto soggetti alle tolleranze dei processi di stampa.

Zanotta spa reserves the right to change, without previous notice, materials, covers, finishes and drawings of the products presented in this catalogue. The textures and colours of materials and finishes are indicative as they are depending on the tolerances of the printing process.

Zanotta spa se réserve le droit d'apporter, sans préavis, des modifications au niveau des matériaux, des revêtements, des finitions et du design des produits présentés dans ce catalogue. Les textures et les couleurs des matériaux et des finitions sont une valeurs indicative parce-que ils changent selon la tolérance aux procédés d'imprimerie.

Zanotta spa behält sich vor, ohne Vorankündigung, Veränderungen an den Materialien, Bezügen, Finish und Zeichnungen der in diesem Katalog vorgestellten Produkte vorzunehmen. Die Texturen und Farben der Materialien und Finish haben einen hinweisenden Wert, da sie von den Toleranzen im Druckprozess abhängig sind.

Zanotta spa se reserva el derecho de aportar modificaciones de dibujo, materiales, acabados y tapicerías, sin que esté obligada a dar aviso anticipado. Las textures y los colores de los materiales y de los acabados tienen solo un valor indicativo porque están sujetos a la tolerancia en los procesos de imprenta.

Art direction
Calvi Brambilla

Graphic design
Tomo Tomo

Pre-press
Alt®aLuce, Milano

Printing
O.G.M. S.p.A., 2024

Copyright© Zanotta SpA, 2024
All rights reserved

Zanotta Spa
I – 20834 Nova Milanese
Via Vittorio Veneto 57
T: + 39 0362 4981
zanottaspa@zanotta.it
www.zanotta.com

